



Meeting Items

- A. Call to Order
- B. Pledge of Allegiance
- C. Roll Call
- D. Approve Order of Agenda
- E. Approval of Minutes -- December 1, 2025
- F. Building Permits

Consent Agenda - Approve the Following:

- a. Bills
- b. Improvement District No. 2290 – 2025 Public Works Mill & Overlay
-- Dustin Scott, City Administrator
 - Cost Analysis Update – Informational Only / No Action Required
- c. Financial Report as of November 30, 2025
- d. Addendum to 2026 Sanitation Fees
- e. 2026 Youthworks Agreement (approved within the 2026 budget)
- f. Games of Chance for St. Paul II Catholic Schools at Trinity Elementary School
- g. Games of Chance for VOLT Volleyball

Regular Agenda

- 1. Public Comment
Members of the public will be allowed 2 minutes and 30 seconds to address the City Commission. Commissioners will not take any official action during this comment period. Please sign up no later than 12 p.m. the day of the City Commission Meeting you wish to attend. City Commission Meeting Public Comment | West Fargo, ND (westfargond.gov)
- 2. Public Hearings (each item will adjourn out of regular meeting into a public hearing)
 - a. Public Hearing and First Reading of Floodplain Management Ordinance Amendment
-- Jerry Wallace, City Engineer
 - Approve 1st Reading of Amended Floodplain Management Ordinance
 - b. Ordinance No. 1266 – Municipal Judge -- Dustin Scott, City Administrator
 - Public Hearing and Consideration of the First Reading
- 3. Contract with City of Fargo (MATBUS) for 2026 transit service
Request for contract approval -- Aaron Nelson, Director of Planning and Zoning
- 4. Court Room Remodel -- Captain Derek Cruff, West Fargo Police Department
- 5. IT CIP Request -- Haider Howitzer, Director of IT
- 6. Improvement District No. 2297 – South Pond Neighborhood Pavement Rehabilitation
-- Jerry Wallace, City Engineer
 - Conduct the Determination of Protest Sufficiency and Approve Associated Resolution

7. Improvement District No. 2296 – Shadow Wood Neighborhood Pavement Rehabilitation
 - Jerry Wallace, City Engineer
 - Conduct the Determination of Protest Sufficiency and Approve Associated Resolution
8. Improvement District No. 6062 – 2026 Sidewalk Improvements
 - Jerry Wallace, City Engineer
 - Approve Amended Engineer's Report and Direct Engineer to prepare Plans and Specifications
9. Project No. 2284 – 2026 HSIP Intersections – Turn Lane Realignment
9th St. E./19th Ave. E., 32nd Ave. E./4th St. E., & Sheyenne St./38th Ave. W.
 - Jerry Wallace, City Engineer
 - Review bid and concur with NDDOT's recommendation.
10. Approve 2026 City Commission Meeting Calendar -- Rachel Richter Lordemann, Director of Communication
11. Renew contract with Steven Mottinger for Indigent Defense Services -- Dustin Scott, City Administrator
12. City Administrator's Report -- Dustin Scott, City Administrator
13. Correspondence
14. Non-Agenda Items
15. Adjourn



Meeting Items

A. Call to Order

The West Fargo City Commission meeting was held in the City of West Fargo Commission Chambers on Monday, December 1, 2025.

B. Pledge of Allegiance

The Pledge of Allegiance was recited.

C. Roll Call

Commissioner Roben Anderson – present; Commissioner Brad Olson – present; Commissioner Bernie Dardis – present; Commissioner Amy Zundel – present; Commissioner Rory Jorgensen – absent; Four of the five Commissioners were present, Commissioner Jorgensen was absent from the meeting.

D. Approve Order of Agenda

Commissioner Zundel moved and Commissioner Anderson seconded to approve the order of agenda. Commissioners Anderson, Olson, Dardis and Zundel voted aye. No Commissioners present voted nay, the motion to approve the order of agenda, was declared carried.

E. Approval of Minutes -- November 17, 2025

Commissioner Olson moved and Commissioner Anderson seconded to approve the minutes of November 17, 2025. Commissioners Anderson, Olson, Dardis and Zundel voted aye. No Commissioners present voted nay, the motion to approve the minutes of November 17, 2025, was declared carried.

F. Building Permits

Commissioner Anderson moved and Commissioner Olson seconded to approve the building permits. Commissioners Anderson, Olson, Dardis and Zundel voted aye. No Commissioners present voted nay, the motion to approve the building permits, was declared carried.



Consent Agenda - Approve the Following:

- a. Bills
- b. Economic Development Advisory Committee appointment of small business and member at large representation
- c. Project No. 6060 – River’s Bend Multi-Use Path and Pedestrian Bridge
 - Approve Resolution dissolving the MOU between the City and Park District
- d. City Owned Right-of-Way within City limits of West Fargo
 - Authorize staff to initiate a season shutdown for all non-emergent permitting and utility work
- e. Restricted Event Permit for Friends of Leroy Turner
- f. Games of Chance for STOMP at West Fargo Sheyenne High School
- g. Games of Chance for Holy Cross Wild Game Feed at Holy Cross Catholic Church
- h. Games of Chance for Alissa Pulkrabek Benefit

Commissioner Olson moved and Commissioner Anderson seconded to approve the consent agenda. Commissioner Zundel recused herself; Anderson, Olson and Dardis voted aye. No Commissioners present voted nay, the motion to approve the consent agenda, was declared carried.

Regular Agenda

1. Public Comment

Members of the public will be allowed 2 minutes and 30 seconds to address the City Commission. Commissioners will not take any official action during this comment period.

Please sign up no later than 12 p.m. the day of the City Commission Meeting you wish to attend. City Commission Meeting Public Comment | West Fargo, ND (westfargond.gov)

2. Public Hearings (each item will adjourn out of regular meeting into a public hearing)

~~**3. Abatement Hearings – Paul Fracassi, Director of Assessing**~~

- ~~• Ryan LLC representing Enclave Property Management on (5) parcels~~

~~Baja Properties~~

~~--02-0952-00010-000~~

~~--02-0952-00030-000~~

~~Shoppes of 4th~~

~~--02-0033-00110-000~~

~~--02-0033-00140-000~~

~~Opere LLC~~

~~--02-4614-00010-000~~

This item was withdrawn from the agenda.



4. FM Metro COG Metro Railroad Needs Study Presentation -- Dan Bergerson, HDR Inc.

• No Action – Informational

There was no action taken, this was informational only.

5. Improvement District No. 1356 – Brookwood Meter Pit Replacement (East Side)

-- Jerry Wallace, City Engineer

• Approve Engineer's Report and Direct Engineer to prepare Plans and Specifications

Commissioner Olson moved and Commissioner Anderson seconded to approve Improvement District No. 1356 – Brookwood Meter Pit Replacement (East Side); Approve Engineer's Report and Direct Engineer to prepare Plans and Specifications. Commissioners Anderson, Olson, Dardis and Zundel voted aye. No Commissioners present voted nay, the motion to approve Improvement District No. 1356 – Brookwood Meter Pit Replacement (East Side); Approve Engineer's Report and Direct Engineer to prepare Plans and Specifications, was declared carried.

~~**6. Project No. 2284 – 2026 HSIP Intersections – Turn Lane Realignments**~~

~~**-- Jerry Wallace, City Engineer**~~

~~**• Review bid and concur with NDDOT's recommendation.**~~

~~This item was withdrawn from the agenda.~~

7. Project No. 6063 – 8th St W Multi-Use Path -- Jerry Wallace, City Engineer

• Review bid and concur with NDDOT's recommendation.

Commissioner Anderson moved and Commissioner Olson seconded to approve Project No. 6063 – 8th St W Multi-Use Path; Review bid and concur with NDDOT's recommendation. Commissioners Anderson, Olson, Dardis and Zundel voted aye. No Commissioners present voted nay, the motion to approve Project No. 6063 – 8th St W Multi-Use Path; Review bid and concur with NDDOT's recommendation, was declared carried.

8. Revised Military Leave Policy -- Dustin Scott, City Administrator

Commissioner Anderson moved and Commissioner Olson seconded to approve the Revised Military Leave Policy. Commissioners Anderson, Olson, Dardis and Zundel voted aye. No Commissioners present voted nay, the motion to approve the Revised Military Leave Policy, was declared carried.

9. City Administrator's Report -- Dustin Scott, City Administrator

- a. Reminder of upcoming neighborhood meetings.
- b. Schedule to outline 2026 Commission meetings to come, next meeting.
- c. Annual evaluations for employee evaluations are scheduled before the end of the year.



West Fargo City Commission Meeting
West Fargo City Hall Commission Chambers
2515 6th St E, West Fargo 58078
Monday, December 1, 2025 5:30 PM

10. Correspondence

Commission President Dardis, reminded everyone of the tree lighting at 5:30 pm on Thursday, at the POW/MIA Plaza.

Commissioner Zundel gave recognition and thank you to the public works staff for their 5,000 miles on City plows and first responders for working over the holiday.

11. Non-Agenda Items

There were no correspondence.

12. Adjourn

Commissioner Olson moved and Commissioner Zundel seconded to adjourn. Commissioners Anderson, Olson, Dardis and Zundel voted aye. No Commissioners present voted nay, the motion to adjourn, was declared carried, the meeting adjourned at 5:53 pm.

**WEST FARGO CITY COMMISSION MEETING
BUILDING DEPARTMENT ACTIVITY REPORT
12/15/2025**

	11/26/2025 Thru 12/11/2025			YEAR TO DATE		
	# PERMITS	# UNITS	VALUATION	# PERMITS	# UNITS	VALUATION
<u>BUILDING NEW</u>						
COMMERCIAL				6		\$ 7,707,000.00
RESIDENTIAL DWELLING	2	2	\$ 1,094,434.00	92	92	\$ 39,554,600.00
RESIDENTIAL TWINHOME						
RESIDENTIAL TOWNHOME						
RESIDENTIAL MULTIPLE						
PUBLIC				1		\$ 339,000.00
CHURCH						
ACCESSORY				136		\$ 2,765,760.00
FOUNDATION ONLY				9		\$ 2,916,512.00
<u>BUILDING REMODEL</u>						
COMMERCIAL	2		\$ 675,000.00	37		\$ 13,787,982.00
RESIDENTIAL	7		\$ 460,568.00	167		\$ 7,324,151.00
PUBLIC				12		\$ 13,598,782.00
CHURCH				1		\$ 38,000.00
ACCESSORY				10		\$ 412,510.00
<u>BUILDING OTHER</u>						
DEMOLITION				2		\$ 5,284.00
MOVE				2		\$ 82,000.00
PERMIT CANCELLATION				1		\$ (5,250,000.00)
TOTALS	11	2	\$ 2,230,002.00	474	92	\$ 83,281,581.00

**WEST FARGO CITY COMMISION MEETING
Building Department Report - Summary**

NO.	CONTRACTOR	ADDRESS	OWNER	VALUATION	PERMIT FOR
251155	Vanterra Foundation Solutions, LLC	844 10 1/2 AVE W	RONALD B & BERNADETTE SWANS	\$ 4,633.00	Remodel - Residential - Install Drain Tile
251157	Benjamin Custom Homes, LLC	2320 10 ST W	JESSICA SIMS	\$ 264,000.00	Remodel - Residential - Addition and Roof Extension
250795	Enclave Construction, LLC	300 23 AVE E	ENCLAVE HQ, LLC	\$ 650,000.00	Remodel - Commercial - Partial Demo & Remodel of 2nd Floor
251149	JR Construction WF LLC	3150 SHEYENNE ST UNIT B	ARROW LLC	\$ 25,000.00	Remodel - Commercial - Walk-in Cooler Addition
251161	DAMON & JENNIFER GOODEN	243 10 1/2 AVE E	DAMON & JENNIFER GOODEN	\$ 25,000.00	Remodel - Residential - Kitchen Remodel
251167	Heritage Homes, LLC	4709 11 ST W	HERITAGE HOMES LLC	\$ 478,523.00	Residential Dwelling
251183	DEVON W LESOINE	314 RAMONA AVE	DEVON W LESOINE	\$ 7,500.00	Remodel - Residential - Basement Remodel
251184	Krueger Construction, Inc.	4749 11 ST W	KRUEGER CONSTRUCTION INC	\$ 615,911.00	Residential Dwelling
251196	Groundworks Minnesota, LLC	901 2 ST E	BETTY L THORESON	\$ 33,935.00	Remodel - Residential - Foundation Repair & Install Drain Tile
251198	PATRICK JOYCE, ETAL	2160 14 ST W	PATRICK JOYCE, ETAL	\$ 10,000.00	Remodel - Residential - Framing Basement
251195	Stone Ridge Builders, Inc.	1137 SOMMERSET PL	CASEY & MIRANDA GLANDT	\$ 115,500.00	Remodel - Residential - Remodel

12/12/25
14:56:23

CITY OF WEST FARGO, ND
Claim Details by Posted Date
For Claims from 12/01/25 to 12/12/25

Page: 1 of 67
Report ID: AP100V

* ... Over spent expenditure

Claim/ Line #	Check	Vendor #/Name/ Invoice #/Inv Date/Description	Document \$/ Line \$	Disc \$	PO #	Fund Org Acct	Object	Proj	Cash Account
129390	C	2954 A-OX WELDING SUPPLY CO INC	12.50						
1	11/30/25	SERVICE CHARGE	12.50			1000 455000	433		101000
0001495187									
		Total for Vendor:	12.50						
129409	C	4550 ABC LOCK & KEY INC	25.00						
1	12/08/25	DUPLICATE KEY	25.00			6020 450000	420		101000
E2582									
		Total for Vendor:	25.00						
129375	C	289 ACME TOOLS	1,336.14						
1	12/04/25	GREASE GUN/SHOVELS	496.12			1000 430001	358		101000
15415922									
2	11/25/25	SHOVELS	242.66			6020 450000	432		101000
15352027									
3	12/02/25	CHAIN OIL	126.90			2210 428000	424		101000
15395788									
4	12/02/25	MISC TOOLS	315.75			1000 430002	432		101000
15396190									
5	12/04/25	#5705 TOOLS	125.10			1000 430002	870		101000
15421005									
6	12/04/25	EXTENSION CORD	29.61			6020 450000	432		101000
15417993									
129379	C	289 ACME TOOLS	1,139.37						
1	12/04/25	WIRE CUTTER/HOLE CUT KIT	307.86			6025 450000	432		101000
15420026									
2	12/04/25	MANDREL KIT/SCAFFOLD	279.59			6025 450000	432		101000
15418052									
3	12/04/25	MISC TOOLS	551.92			6025 450000	432		101000
15417753									
129497	C	289 ACME TOOLS	3,132.60						
1	12/04/25	#5705 TOOLS	3,132.60			1000 430002	870		101000
15421371									

12/12/25
14:56:23

CITY OF WEST FARGO, ND
Claim Details by Posted Date
For Claims from 12/01/25 to 12/12/25

Page: 2 of 67
Report ID: AP100V

* ... Over spent expenditure

Claim/ Line #	Check Invoice #/Inv Date/Description	Vendor #/Name/ Invoice #/Inv Date/Description	Document \$/ Line \$	Disc \$	PO #	Fund Org Acct	Object	Proj	Cash Account
129508	C	289 ACME TOOLS	612.12						
1	12/10/25	#5705 TOOLS	612.12			1000 430002	870		101000
		15460914							
		Total for Vendor:	6,220.23						
129552	C	2947 ALLSTATE PETERBILT OF FARGO	29.86						
1	12/08/25	#4100 SPARES KIT	29.86			6010 450200	427		101000
		4004499683							
		Total for Vendor:	29.86						
129310	E	3490 AMAZON CAPITAL SERVICES	19.99						
1	1TRG-R1H4-	12/02/25 Disposable Shoe Covers	19.99			1000 418000	410		101000
		1TRG-R1H4-C3YF							
129312	E	3490 AMAZON CAPITAL SERVICES	166.36						
1	1TFLXHCWDN	12/01/25 Bluetooth headset	109.90			1000 414200	410		101000
		1TFL-XHCW-DNXC							
2	1TFLXHCWDN	12/01/25 Cable wire ties	41.97			6020 450000	412		101000
		1TFL-XHCW-DNXC							
3	1TFLXHCWDN	12/01/25 Cable wire ties	14.49			6020 450000	412		101000
		1TFL-XHCW-DNXC							
129313	E	3490 AMAZON CAPITAL SERVICES	181.31						
1	1LT4RJLTHK	12/01/25 Felt Tip Pens	36.48			1000 414200	410		101000
		1LT4-RJLT-HKC1							
2	1LT4RJLTHK	12/01/25 Hanging file folders	13.79			1000 414200	410		101000
		1LT4-RJLT-HKC1							
3	1LT4RJLTHK	12/01/25 Planner	18.81			1000 414200	410		101000
		1LT4-RJLT-HKC1							
4	1LT4RJLTHK	12/01/25 Permanent Markers	23.24			1000 414200	410		101000
		1LT4-RJLT-HKC1							
5	1LT4RJLTHK	12/01/25 Desk Organizer	41.00			1000 414200	410		101000
		1LT4-RJLT-HKC1							
6	1LT4RJLTHK	12/01/25 Air Purifier Filter	47.99			1000 414200	410		101000
		1LT4-RJLT-HKC1							

12/12/25
14:56:23

CITY OF WEST FARGO, ND
Claim Details by Posted Date
For Claims from 12/01/25 to 12/12/25

Page: 3 of 67
Report ID: AP100V

* ... Over spent expenditure

Claim/ Line #	Check	Vendor #/Name/ Invoice #/Inv Date/Description	Document \$/ Line \$	Disc \$	PO #	Fund Org Acct	Object	Proj	Cash Account
129314	E	3490 AMAZON CAPITAL SERVICES	1,113.09						
1	1L9HHL97X9	11/29/25 Desk Calendar	10.87			1000 414200	410		101000
	1L9H-HL97-X9LJ								
2	1L9HHL97X9	11/29/25 Cable Connector-3 port	356.97			6020 450000	412		101000
	1L9H-HL97-X9LJ								
3	1L9HHL97X9	11/29/25 insulated splice connector	199.95			6020 450000	412		101000
	1L9H-HL97-X9LJ								
4	1L9HHL97X9	11/29/25 Magnetic locator w/LCD Scr	545.30			6020 450000	412		101000
	1L9H-HL97-X9LJ								
129355	E	3490 AMAZON CAPITAL SERVICES	90.82						
1	12/01/25	k9 tugs	75.98			1000 421000	915		101000
	IVT3-X7KM-CVDX								
2	11/29/25	k9 training treats	14.84			1000 421000	915		101000
	1YWC-HLDX-WTGT								
129364	E	3490 AMAZON CAPITAL SERVICES	542.12						
1	11/25/25	RIPSAW TOOL	382.13			6020 450000	641		101000
	1WLVK6GV9QVM								
2	12/01/25	#5307 TRAILER HITCH	159.99			1000 430001	322		101000
	1YR9C311CXJH								
129420	E	3490 AMAZON CAPITAL SERVICES	8.00						
		Fire Department							
1	12/01/25	FD J Neeb -2-pants	143.96			2060 415200	422		101000
	14NY-Q3JQ-977N								
2	12/01/25	FD J Neeb pants return	-68.98			2060 415200	422		101000
	13nw-r14m-1gyn								
3	12/01/25	FD J Neeb pants return	-66.98			2060 415200	422		101000
	1H39-369L-1HMK								
129472	E	3490 AMAZON CAPITAL SERVICES	178.11						
1	12/08/25	FACEMASKS	105.60			6010 450200	639		101000
	1WTW7CLDW3RC								
2	12/08/25	T FRAEDRICH - SHIRTS	72.51			6010 450200	422		101000
	1K3DTJDW31TW								

12/12/25
14:56:23

CITY OF WEST FARGO, ND
Claim Details by Posted Date
For Claims from 12/01/25 to 12/12/25

Page: 4 of 67
Report ID: AP100V

* ... Over spent expenditure

Claim/ Line #	Check	Vendor #/Name/ Invoice #/Inv Date/Description	Document \$/ Line \$	Disc \$	PO #	Fund Org Acct	Object	Proj	Cash Account
129486	E	3490 AMAZON CAPITAL SERVICES	1,076.55						
1	12/06/25	Flash drive - IT	104.99			1000 414104	497		101000
		14NC-L9YC-NMJ3							
2	12/08/25	Laser measure units - Assessin	612.79			1000 414101	410		101000
		1QQ7-W91G-DJTN							
3	12/09/25	Packing tape	39.46			1000 415000	410		101000
		197D-WTJM-FY69							
4	11/26/25	Whiteboard markers/erasers	35.94			1000 414100	410		101000
		1C6F-XQVQ-TMFD							
5	12/09/25	Office supplies - Eng	233.83			1000 414200	410		101000
		197D-WTJM-FYKH							
6	12/11/25	File folder organizers - Fin	49.54			1000 414100	410		101000
		1CP6-MNMR-DLG6							
129524	E	3490 AMAZON CAPITAL SERVICES	194.94						
1	12/08/25	R OLSON - WINTER BOOTS	194.94			6020 450000	422		101000
		19CX1M6M3LPY							
		Total for Vendor:	3,571.29						
129436	-95268E	5229 AMB INVESTMENTS, LLC	47,700.00						
		New City Hall / Satellite Library							
1	12/01/25	Dec 2025 Lease - City Hall	44,922.57			1001 415000	389		101000
2	12/01/25	Dec 2025 Lease - Satellite Lib	2,777.43			7000 411600	333		101000
		Total for Vendor:	47,700.00						
129425		2844 AMERICAN MAIL HOUSE INC	235.56						
1	10/16/25	SA MAILINGS	235.56			6010 450200	668		101000
		113964							
		Total for Vendor:	235.56						
129550	C	317 AMERICAN WELDING & GAS, INC.	150.33						
1	12/10/25	O2/ACETLYNE	150.33			1000 430000	433		101000
		0011317632							
		Total for Vendor:	150.33						

* ... Over spent expenditure

Claim/ Line #	Check Invoice #/Inv Date/Description	Vendor #/Name/ Invoice #/Inv Date/Description	Document \$/ Line \$	Disc \$	PO #	Fund Org Acct	Object	Proj	Cash Account
129488	3160 APPLE BOOKS		1,578.52						
1	12/05/25 BOOKS		1,578.52			7000 411600	662		101000
119830									
		Total for Vendor:	1,578.52						
129480	C 5449 ASSUREHIRE		473.31						
	Background Checks / Drug Screens / Credit Checks for New Hires								
1	122530 12/01/25 Background/Drug Screens		459.31			1000 414103	399		101000
122530									
2	122530 12/01/25 Credit Checks - PD		14.00			1000 421000	387		101000
122530									
		Total for Vendor:	473.31						
129528	-95263E 4672 ASURE PAYROLL TAX MANAGEMENT		281,035.34						
	12/12/2025 Payroll								
1	12/12/25 Social Security		127,354.18			1000 212501			101000
2	12/12/25 Medicare		30,119.32			1000 212502			101000
3	12/12/25 Federal Income Tax		112,831.84			1000 212503			101000
4	12/12/25 ND State Tax		5,626.00			1000 212504			101000
5	12/12/25 MN State Tax		5,104.00			1000 212505			101000
		Total for Vendor:	281,035.34						
129507	C 2931 AUTO VALUE PARTS STORES		583.88						
1	12/08/25 #5306 BATTERY TERM LUG		4.77			1000 430001	427		101000
99373891									
2	12/02/59 FILTERS		17.75			1000 415000	427		101000
99373936									
3	12/10/25 BULK BATTERY/WELDING/LUG		258.68			1000 430000	427		101000
99374289									
4	12/09/25 FILTERS		172.44			6025 450000	427		101000
99373940									
5	12/08/25 FILTERS		90.81			6010 450200	427		101000
99373848									
6	12/09/25 FILTERS		37.72			6020 450000	427		101000
99373937									
7	12/09/25 HD AIR/FLEET CONST		143.47			6010 450200	427		101000
99373939									

12/12/25
14:56:23

CITY OF WEST FARGO, ND
Claim Details by Posted Date
For Claims from 12/01/25 to 12/12/25

Page: 6 of 67
Report ID: AP100V

* ... Over spent expenditure

Claim/ Line #	Check Invoice #/Inv Date/Description	Vendor #/Name/ #/Inv Date/Description	Document \$/ Line \$	Disc \$	PO #	Fund Org Acct	Object	Proj	Cash Account
8	12/09/25	FILTERS	3.35			1000 430000	427		101000
99373938									
9	12/22/59	FILTERS	3.35			6025 450000	427		101000
99372583									
10	12/02/28	FILTERS	7.20			1000 421000	427		101000
99372581									
11	12/02/25	FILTERS	3.51			1000 415000	427		101000
99372584									
12	11/25/25	HD HYD FLEET/CONST	28.66			2210 428000	427		101000
99371717									
13	12/02/25	FILTERS	6.70			1000 430002	427		101000
99372582									
14	12/02/25	#4100 HD AIR CONST	59.09			6010 450200	427		101000
99372745									
15	11/25/25	FILTERS	57.37			6025 450000	427		101000
99371721									
16	12/02/25	BEARING - RETURN	-310.99			1000 430000	427		101000
99372603									
		Total for Vendor:	583.88						
129473		5477 BAKER SNOW & ICE MANAGEMENT	750.00						
1	12/02/25	LIGHTS - NOVEMBER SNOW REMOVAL	750.00			1000 430001	381		101000
463									
		Total for Vendor:	750.00						
129349		43 BATTERIESPLUS c/o Bat 34 Inc	410.85						
1	12/05/25	robot equipment	410.85			1000 421000	641		101000
P87760533									
		Total for Vendor:	410.85						
129449		C 3149 BEE SEEN GEAR	2,090.00						
1	12/09/25	pvc back patches	2,090.00			1000 421000	422		101000
73003									

* ... Over spent expenditure

Claim/ Line #	Check	Vendor #/Name/ Invoice #/Inv Date/Description	Document \$/ Line \$	Disc \$	PO #	Fund Org Acct	Object	Proj	Cash Account
129570	C	3149 BEE SEEN GEAR	4,363.84						
		2025 clothing allowance.							
1	12/10/25	D Christensen-new uniforms	412.97			2060 415200	422		101000
73023									
2	12/02/25	J West-new uniforms	159.98			2060 415200	422		101000
72628									
3	12/05/25	J Johnson-New Uniforms	221.99			2060 415200	422		101000
72625									
4	12/05/25	B Temp-New Uniforms	322.98			2060 415200	422		101000
72628									
5	12/05/25	M Ashland-New Uniforms	142.00			2060 415200	422		101000
72631									
6	12/05/25	M Dahlson-New Uniforms	221.99			2060 415200	422		101000
72638									
7	12/05/25	N Wavra-New Uniforms	322.99			2060 415200	422		101000
72651									
8	12/05/25	R Qualley-New Uniforms	163.00			2060 415200	422		101000
72667									
9	12/05/25	M Dahlson-New Uniforms	244.00			2060 415200	422		101000
72756									
10	12/08/25	M Ashland-New Uniforms	155.00			2060 415200	422		101000
72943									
11	12/08/25	H Kalina-New Uniforms	100.99			2060 415200	422		101000
72953									
12	12/08/25	J Dick-New Uniforms	92.00			2060 415200	422		101000
72962									
13	12/08/25	C Hodgson-New Uniforms	99.00			2060 415200	422		101000
72918									
14	12/08/25	K Miller-New Uniforms	215.00			2060 415200	422		101000
72975									
15	12/09/25	T Matelski-New Uniforms	233.99			2060 415200	422		101000
72669									
16	12/09/25	A Nienas-New Uniforms	292.00			2060 415200	422		101000
72672									
17	12/09/25	E Menge-New Uniforms	194.00			2060 415200	422		101000
72713									

* ... Over spent expenditure

Claim/ Line #	Check Invoice #/Inv Date/Description	Vendor #/Name/ Invoice #/Inv Date/Description	Document \$/ Line \$	Disc \$	PO #	Fund Org Acct	Object	Proj	Cash Account
18 72699	12/09/25	B Gaugler-New Uniforms	69.00			2060 415200	422		101000
19 72757	12/09/25	L Pettinger-New Uniforms	325.98			2060 415200	422		101000
20 73013	12/09/25	M Obach-New Uniforms	199.99			2060 415200	422		101000
21 72639	12/05/25	M O'Bryant-New Uniforms	174.99			2060 415200	422		101000
129575 1 73041	C 12/12/25	3149 BEE SEEN GEAR class A shoulder patch	300.00 300.00			1000 421000	422		101000
Total for Vendor:			6,753.84						
129408 1 104705	C 12/02/25	36 BERT'S TRUCK EQUIPMENT CASTER WHEEL/HARDWARE	1,973.33 166.43			1000 455000	420		101000
2 104854	12/04/25	#5306B CUTTING EDGES	1,806.90			1000 430001	381		101000
Total for Vendor:			1,973.33						
129405 1 95161571	C 12/01/25	5655 BFIRST INDUSTRIAL PLOW BOLTS	42.50 42.50			1000 430000	381		101000
129515 1 95161571-02	C 12/08/25	5655 BFIRST INDUSTRIAL PLOW BOLTS	415.34 23.20			1000 430000	381		101000
2 95161571-01	12/04/25	PLOW BOLTS	353.75			1000 430000	381		101000
3 95161845-00	12/08/25	HEX NUTS	38.39			1000 430000	381		101000
Total for Vendor:			457.84						

12/12/25
14:56:23

CITY OF WEST FARGO, ND
Claim Details by Posted Date
For Claims from 12/01/25 to 12/12/25

Page: 9 of 67
Report ID: AP100V

* ... Over spent expenditure

Claim/ Line #	Check Invoice #	Vendor #/Name/ Inv Date/Description	Document \$/ Line \$	Disc \$	PO #	Fund Org Acct	Object	Proj	Cash Account
129468	-95265E	3552 BLUE CROSS BLUE SHIELD OF ND December 2025 Premium - Med/Dental/Vision	375,954.52						
1	11/20/25	December 2025 Premium	375,954.52			1000 212539			101000
		251120127741							
		Total for Vendor:	375,954.52						
129559	C	3489 BOLTON & MENK, INC	1,250.00						
1	0380666	11/28/25 Project 2294	1,250.00			4223 480000	313		101000
		0380666							
		Total for Vendor:	1,250.00						
129427		3512 BOUND TREE MEDICAL, LLC	1,088.64						
1	11/21/25	FD Medical Supplies	148.74			2060 415200	500		101000
		86003505							
2	12/01/25	FD Medical Supplies	939.90			2060 415200	500		101000
		86011453							
		Total for Vendor:	1,088.64						
129516	C	652 BRENCO CORPORATION	105.00						
1	12/05/25	#7035 RM 110 1 GAL	21.00			6025 450000	427		101000
		0178102-IN							
2	12/08/25	RM 110 1 GAL	84.00			6025 450000	427		101000
		0178152-IN							
		Total for Vendor:	105.00						
129308		999999 BRITTANY HOSMAN	65.94						
		refund of permit fee less 20% for staff time. Permit was cancelled							
1	12/01/25	Refund Permit #251045	65.94			1000 322300			101000
		Refund Permit Fee							
		Total for Vendor:	65.94						
129456	C	351 BUSINESS ESSENTIALS	54.42						
1	10/16/25	PAPER TOWELS	54.42			7000 411600	410		101000
		WO-1365761-2							
		Total for Vendor:	54.42						

12/12/25
14:56:23

CITY OF WEST FARGO, ND
Claim Details by Posted Date
For Claims from 12/01/25 to 12/12/25

Page: 10 of 67
Report ID: AP100V

* ... Over spent expenditure

Claim/ Line #	Check	Vendor #/Name/ Invoice #/Inv Date/Description	Document \$/ Line \$	Disc \$	PO #	Fund Org Acct	Object	Proj	Cash Account
129369	C	39 BUTLER MACHINERY	8,673.69						
1	11/27/25	CAT RENTAL - WING REPAIR	87.50			1000 430000	427		101000
		00WO0290918							
2	11/26/25	#7709 THROTTLE REPAIR	8,467.69			4387 480000	427		101000
		00WO0290875							
3	12/03/25	HARDWARE	118.50			1000 430000	381		101000
		00PS0672407							
129504	C	39 BUTLER MACHINERY	443.96						
1	12/09/25	HARDWARE	120.00			1000 430000	381		101000
		00PS0672804							
2	12/10/25	#3062 CROSSOVER RELEIF	378.46			1000 430000	427		101000
		00PS0672867							
3	12/10/25	HARDWARE - RET	-54.50			1000 430000	381		101000
		00CS0065106							
		Total for Vendor:	9,117.65						
129428	C	4508 CARE RESOURCE CONNECTION	3,000.00						
1	12/01/25	FD 12-1 thru 12-31 Services	3,000.00			2060 415200	428		101000
		7910							
		Total for Vendor:	3,000.00						
129430	E	51 CASS COUNTY ELECTRIC COOP	2,039.72						
1	12/05/25	FD ST 76 November Utilities	2,039.72			2060 415200	527		101000
		1090222-Nov							
129530	E	51 CASS COUNTY ELECTRIC COOP	400.03						
1	428342 Dec 12/05/25	Airport 10/31/25-11/30/25	400.03			7050 500000	420		101000
		428342 12/25							
129539	E	51 CASS COUNTY ELECTRIC COOP	45,280.65						
1	12/10/25	THE LIGHTS CITY HOUSE METER	432.98			2310 452120	527		101000
		1168004							
2	12/10/25	THE LIGHTS PARKING RAMP	1,389.36			2310 452120	527		101000
		1163203							
3	12/10/25	THE LIGHTS STAGE & COURTYARD	1,992.31			2310 452120	527		101000
		1163206							

12/12/25
14:56:23

CITY OF WEST FARGO, ND
Claim Details by Posted Date
For Claims from 12/01/25 to 12/12/25

Page: 11 of 67
Report ID: AP100V

* ... Over spent expenditure

Claim/ Line #	Check Invoice #/Inv Date/Description	Vendor #/Name/ #/Inv Date/Description	Document \$/ Line \$	Disc \$	PO #	Fund Org Acct	Object	Proj	Cash Account
4 1156424	12/10/25	TRANSFER STATION	268.70			6010 450200	527		101000
5 1156424	12/10/25	STREET LIGHT FEED POINTS	22,636.30			1000 430002	527		101000
6 1156426	12/10/25	INERT LANDFILL	137.55			6010 450200	527		101000
7 1156426	12/10/25	LIFT STATIONS	18,423.45			6025 450000	527		101000
129565 1 1190696	E 1190696 12/25	51 CASS COUNTY ELECTRIC COOP 12 12/10/25 New City Hall (WEX Buildin	5,673.66 5,673.66			1001 415000	527		101000
Total for Vendor:			53,394.06						
129325 1 46230		1618 CASS COUNTY ELECTRIC COOP INC 12/02/25 Dist 2265	8,477.24 8,477.24			4793 480000	670		101000
129560 1 46176		1618 CASS COUNTY ELECTRIC COOP INC 11/24/25 Dist 3006	400.00 400.00			4003 480000	670		101000
Total for Vendor:			8,877.24						
129347 1 INV012430		1355 CASS COUNTY GOVERNMENT 11/24/25 oct 2025 jail housing	3,230.00 3,145.00			1000 421000	398		101000
2 INV012431		11/24/25 oct 2025 intox	85.00			1000 421000	398		101000
Total for Vendor:			3,230.00						
129563 1 Pay App 12	C Pay App 12	2909 CC STEEL LLC 11/24/25 Project 1348	65,400.00 65,400.00			4444 480000	670		101000
Total for Vendor:			65,400.00						

12/12/25
14:56:23

CITY OF WEST FARGO, ND
Claim Details by Posted Date
For Claims from 12/01/25 to 12/12/25

Page: 12 of 67
Report ID: AP100V

* ... Over spent expenditure

Claim/ Line #	Check	Vendor #/Name/ Invoice #/Inv Date/Description	Document \$/ Line \$	Disc \$	PO #	Fund Org Acct	Object	Proj	Cash Account
129351	C	1512 CDW GOVERNMENT, INC	1,245.92						
1	11/26/25	nov 2025 call cabinet recordin	1,245.92			1000 421000	497		101000
		AH1QM8L							
129571	C	1512 CDW GOVERNMENT, INC	1,245.92						
1	12/10/25	dec 2025 call cabinet	1,245.92			1000 421000	497		101000
		AH27L4E							
		Total for Vendor:	2,491.84						
129417		62 CENTRAL DOOR & HARDWARE INC	53.88						
1	11/25/25	DOOR SWEEPS	53.88			6020 450000	420		101000
		225491							
		Total for Vendor:	53.88						
129444	E	1777 CENTURY LINK	215.28						
1	12/01/25	dec 2025 - police sirens	215.28			1000 421000	356		101000
		Total for Vendor:	215.28						
129446		3874 CHASE STEEL SERVICES INC	567.52						
1	12/08/25	robot steel	567.52			1000 421000	641		101000
		093977							
		Total for Vendor:	567.52						
129483	C	1808 CHERRY LAKE PUBLISHING	556.02						
1	11/11/25	BOOKS	556.02			7000 411600	662		101000
		285207							
		Total for Vendor:	556.02						
129511		3216 CINTAS	185.52						
1	12/05/25	RUG SERVICE	185.52			1000 455000	420		101000
		4252101807							
		Total for Vendor:	185.52						

12/12/25
14:56:23

CITY OF WEST FARGO, ND
Claim Details by Posted Date
For Claims from 12/01/25 to 12/12/25

Page: 13 of 67
Report ID: AP100V

* ... Over spent expenditure

Claim/ Line #	Check Invoice #/Inv Date/Description	Vendor #/Name/ Invoice #/Inv Date/Description	Document \$/ Line \$	Disc \$	PO #	Fund Org Acct	Object	Proj	Cash Account
129394		111 CITY OF FARGO	610.00						
1	11/26/25	WATER TESTING	560.00			6020 450000	335		101000
492614									
2	11/26/25	WATER TESTING	50.00			6025 450000	335		101000
492615									
129401		111 CITY OF FARGO	53,694.06						
1	11/26/25	LANDFILL FEES	26,380.14			6010 450200	355		101000
492612									
2	11/19/25	LANDFILL FEES	27,313.92			6010 450200	355		101000
492212									
129461		111 CITY OF FARGO	38,014.70						
1	492613 11/26/25	Paratransit Rides - Oct 2025	38,014.70			1000 415000	376		101000
492613									
		Total for Vendor:	92,318.76						
129476		2880 CITY OF FARGO	660,602.97						
1	12/05/25	1 MAIN AVE (WATER)	125,762.60			6020 450000	345		101000
2	12/05/25	1 GSR (WATER)	101,350.80			6020 450000	345		101000
3	12/05/25	5635 14TH AVE N (WATER)	29.60			6020 450000	345		101000
4	12/05/25	1 32ND AVE S (WATER)	117,824.30			6020 450000	345		101000
5	12/05/25	2220 57TH ST N (SEWER)	315,635.67			6025 450000	347		101000
		Total for Vendor:	660,602.97						
129520		111 CITY OF FARGO	22,528.17						
1	12/03/25	LANDFILL FEES	22,528.17			6010 450200	355		101000
492741									
		Total for Vendor:	22,528.17						
129307		C 3167 CITY OF WEST FARGO	77.82						
1	31935 Nov 11/20/25	Airport Dumpster-Nov	77.82			7050 500000	420		101000
31935 Nov 25									
		Total for Vendor:	77.82						

12/12/25
14:56:23

CITY OF WEST FARGO, ND
Claim Details by Posted Date
For Claims from 12/01/25 to 12/12/25

Page: 14 of 67
Report ID: AP100V

* ... Over spent expenditure

Claim/ Line #	Check Invoice #/Inv Date/Description	Vendor #/Name/ Invoice #/Inv Date/Description	Document \$/ Line \$	Disc \$	PO #	Fund Org Acct	Object	Proj	Cash Account
129423		5076 CODY JOCHIM	126.00						
		DOT TRAINING - MENDOTA HEIGHTS, MN							
1	12/04/25	TRAVEL REIMBURSEMENT	126.00			1000 455000	340		101000
		Total for Vendor:	126.00						
129415	C	133 COLE PAPERS INC	1,970.22						
1	12/02/25	PAPER PRODUCTS - CH	197.74			1000 455000	500		101000
10655741									
2	12/02/25	PAPER PRODUCTS - PW	725.72			6020 450000	500		101000
10655740									
3	12/02/25	PAPER PRODUCTS - SA	246.96			6010 450200	500		101000
10655743									
4	12/02/25	PAPER PRODUCTS - PD	799.80			1000 455000	500		101000
10655742									
		Total for Vendor:	1,970.22						
129324	C	3530 CONNECTWISE	336.60						
1	01503676 11/30/25	ScreenConnect - Dec subscrip	336.60			1000 414104	497		101000
		INV01503676							
		Total for Vendor:	336.60						
129344	E	229 CONSOLIDATED COMMUNICATIONS	175.00						
1	12/01/25	dec 2025 ICAC	175.00			1000 421000	497		101000
129576	E	229 CONSOLIDATED COMMUNICATIONS	509.50						
		FD lines from old building that were put into sleep mode. TMW							
1	12/01/25	701-364-9536/0 FD old bldg	509.50			2060 415200	527		101000
		7013649536/0 106 1st st							
		Total for Vendor:	684.50						
129526	C	5412 CONTINENTAL UTILITY SOLUTIONS	63,040.80						
		02/01/26-01/31/27							
1	INVC-13566 12/05/25	UB Software - annual fees	21,013.60			6010 140000			101000
		INVC-13566							
2	INVC-13566 12/05/25	UB Software - annual fees	21,013.60			6020 140000			101000
		INVC-13566							

12/12/25
14:56:23

CITY OF WEST FARGO, ND
Claim Details by Posted Date
For Claims from 12/01/25 to 12/12/25

Page: 15 of 67
Report ID: AP100V

* ... Over spent expenditure

Claim/ Line #	Check Invoice #/Inv Date/Description	Vendor #/Name/ Invoice #/Inv Date/Description	Document \$/ Line \$	Disc \$	PO #	Fund Org Acct	Object	Proj	Cash Account
3	INVC-13566	12/05/25 UB Software - annual fees	21,013.60			6025 140000			101000
	INVC-13566								
		Total for Vendor:	63,040.80						
129381		3245 CORE & MAIN	997.50						
1	12/05/25	TERMINAL SCREWS	778.41			4972 480000	670		101000
8318									
2	12/05/25	DUCTILE IRON FILLER FLANGE	219.09			6020 450000	433		101000
19335									
129544		3245 CORE & MAIN	1,560.11						
1	12/10/25	A3 FLOAT SHAFT	1,560.11			6025 450000	439		101000
19596									
		Total for Vendor:	2,557.61						
129395		60 CROSSCOUNTRY FREIGHT SOLUTIONS	151.05						
1	11/24/25	SHIPPING	151.05			6025 450000	335		101000
1479709									
		Total for Vendor:	151.05						
129431		C 1633 CROWN TROPHY	285.90						
1	12/02/25	12-25 Train Acad. Awards	285.90			2060 415200	378		101000
72133									
		Total for Vendor:	285.90						
129432		C 65 CURT'S LOCK & KEY	150.00						
1	12/01/25	FD ST76 EOC lock change	150.00			2060 415200	494		101000
306049									
		Total for Vendor:	150.00						
129365		C 1675 DAKOTA FLUID POWER, INC	2.40						
1	11/06/25	#3005 PIPE PLUG	2.40			1000 430000	427		101000
7401150									

12/12/25
14:56:23

CITY OF WEST FARGO, ND
Claim Details by Posted Date
For Claims from 12/01/25 to 12/12/25

Page: 16 of 67
Report ID: AP100V

* ... Over spent expenditure

Claim/ Line #	Check	Vendor #/Name/ Invoice #/Inv Date/Description	Document \$/ Line \$	Disc \$	PO #	Fund Org Acct	Object	Proj	Cash Account
129506	C	1675 DAKOTA FLUID POWER, INC	19.29						
1	12/03/25	ORING	19.29			1000 430000	427		101000
7408981									
		Total for Vendor:	21.69						
129350	C	2514 DAKOTA MAILING & SHIPPING	106.45						
1	12/05/25	postage machine ink	106.45			1000 421000	410		101000
87004									
		Total for Vendor:	106.45						
129393	C	624 DAKOTA SUPPLY GROUP	78.27						
1	11/24/25	GATE VALVE FNPT-NL	78.27			6020 450000	433		101000
S105240216									
		Total for Vendor:	78.27						
129564		90 DAKOTA UNDERGROUND	15,462.70						
1	Pay App 5 12/15/25	Project 1353	15,462.70			4189 480000	670		101000
Pay App 5									
		Total for Vendor:	15,462.70						
129437	-95267E	3050 DAKOTA UPREIT LIMITED	7,974.68						
		Pioneer Center - December 2025 rent							
		FINAL PAYMENT							
1	12/01/25	Common Area - Dec 2025	2,402.29			1001 415000	389		101000
2	12/01/25	Base Rent - Dec 2025	5,572.39			1001 415000	389		101000
		Total for Vendor:	7,974.68						
129433		3567 DAN FULLER	600.00						
1	12/09/25	2025 Awards Banq. reimb music	600.00			2060 415200	378		101000
2025 Awards Banq.									
		Total for Vendor:	600.00						
129531	C	2948 DELTA 54 AVIATION LLC	3,800.00						
1	Dec 2025 12/10/25	Airport Management Fees	3,800.00			7050 500000	307		101000
Dec 2025									
		Total for Vendor:	3,800.00						

* ... Over spent expenditure

Claim/ Line #	Check	Vendor #/Name/ Invoice #/Inv Date/Description	Document \$/ Line \$	Disc \$	PO #	Fund Org Acct	Object	Proj	Cash Account
129434	C	5268 DINGES FIRE COMPANY	2,050.00						
1	12/04/25	FD GEN2 Rescue Manikin	2,050.00			2060 415200	340		101000
79623									
		Total for Vendor:	2,050.00						
129522		5120 ERIC JOHNSON	35.00						
1	12/09/25	COUPLING	35.00			6025 450000	439		101000
		Total for Vendor:	35.00						
129577		3667 ESSENTIA HEALTH	19.00						
		J West had to go to 52nd clinic for annual physical blood draw. Occ health machine was down.							
1	11/18/25	J West Annual Physical	19.00			2060 415200	996		101000
		Guar #400178498							
		Total for Vendor:	19.00						
129358		2862 ESSENTIA HEALTH - FARGO	3,886.61						
1	12/02/25	annual physical	1,292.00			1000 421000	996		101000
		890002547.11.2025							
2	12/02/25	cardiac screening for three	280.00			1000 421000	387		101000
		890002547.11.2025							
3	12/02/25	cardiac screen - mickelson	754.87			1000 421000	387		101000
		890002547.11.2025.1							
4	12/02/25	cardiac screen - borg	754.87			1000 421000	387		101000
		890002547.11.2025.2							
5	12/02/25	cardiac screen - crouse	754.87			1000 421000	387		101000
		890002547.11.2025.3							
6		cardiac screen - boyer	50.00			1000 421000	387		101000
		890002547.11.2025.4							
129435		2862 ESSENTIA HEALTH - FARGO	1,537.00						
1	12/02/25	FD October Physicals	1,537.00			2060 415200	996		101000
		890002546.11.2025							

* ... Over spent expenditure

Claim/ Line #	Check Invoice #/Inv Date/Description	Vendor #/Name/ Invoice #/Inv Date/Description	Document \$/ Line \$	Disc \$	PO #	Fund Org Acct	Object	Proj	Cash Account
129534	2862 ESSENTIA HEALTH - FARGO		597.00						
	Random drug screens								
1	08/28/25 J Benedict - Forestry		70.00			2210 428000	387		101000
890000526.08.2025									
2	08/28/25 C Costello - Water		105.00			6020 450000	387		101000
890000526.08.2025									
3	08/28/25 A Spores - Street		60.00			1000 430000	387		101000
890000526.08.2025									
4	08/28/25 K Sather - Sanitation		60.00			6010 450200	387		101000
890000526.08.2025									
5	08/28/25 T Freadrich - Sanitation		60.00			6010 450200	387		101000
890000526.08.2025									
6	08/28/25 S Hagen - Sanitation		60.00			6010 450200	387		101000
890000526.08.2025									
7	08/28/25 J Freeman - Sewer		91.00			6025 450000	387		101000
890000526.08.2025									
8	08/28/25 T Bucholz - Water		91.00			6020 450000	387		101000
890000526.08.2025									
129535	2862 ESSENTIA HEALTH - FARGO		360.00						
	Random drug screens								
1	12/02/25 J Benedict - Forestry		60.00			2210 428000	387		101000
890000526.11.2025									
2	12/02/25 E Johnson - Sewer		60.00			6025 450000	387		101000
890000526.11.2025									
3	12/02/25 T Brock - Street		60.00			1000 430000	387		101000
890000526.11.2025									
4	12/02/25 B Gast - Street		60.00			1000 430000	387		101000
890000526.11.2025									
5	12/02/25 J Nelson - Street		60.00			1000 430000	387		101000
890000526.11.2025									
6	12/02/25 D Heizelman - Street		60.00			1000 430000	387		101000
890000526.11.2025									
	Total for Vendor:		6,380.61						

12/12/25
14:56:23

CITY OF WEST FARGO, ND
Claim Details by Posted Date
For Claims from 12/01/25 to 12/12/25

Page: 19 of 67
Report ID: AP100V

* ... Over spent expenditure

Claim/ Line #	Check	Vendor #/Name/ Invoice #/Inv Date/Description	Document \$/ Line \$	Disc \$	PO #	Fund Org Acct	Object	Proj	Cash Account
129404	C	1851 F/S MANUFACTURING	65.05						
1	11/24/25	ADAPTERS/COUPLERS	54.02			1000 430000	432		101000
207615									
2	11/24/25	HARDWARE	11.03			1000 430001	427		101000
207620									
		Total for Vendor:	65.05						
129319	117821S	999999 FARGO BILLIARDS & GASTROPUB	1,888.00						
1	12/02/25	holiday event	1,888.00			2529 421000	375		101000
		Total for Vendor:	1,888.00						
129383	C	660 FARGO FREIGHTLINER	30.19						
1	12/02/25	#4201 HORN BRACKET	30.19			6010 450200	427		101000
X101198564									
		Total for Vendor:	30.19						
129368	C	124 FASTENAL	55.81						
1	12/05/25	HARDWARE	55.81			1000 430000	487		101000
NDFAR328492									
		Total for Vendor:	55.81						
129341		151 FEDERAL EXPRESS	11.83						
1	12/03/25	ND lab package	11.83			1000 421000	661		101000
9-090-01365									
		Total for Vendor:	11.83						
129362	C	5588 FLEET CHARGE	469.83						
1	11/24/25	#4007 SHOCK ABSORBER	117.10			6010 450200	427		101000
X20225432701									
2	12/01/25	#2006 HVAC BLOWER MOTOR	68.93			6020 450000	427		101000
X20225466301									
3	12/01/25	#262 HEATER KIT	283.80			6020 450000	427		101000
X20225444201									

12/12/25
14:56:23

CITY OF WEST FARGO, ND
Claim Details by Posted Date
For Claims from 12/01/25 to 12/12/25

Page: 20 of 67
Report ID: AP100V

* ... Over spent expenditure

Claim/ Line #	Check	Vendor #/Name/ Invoice #/Inv Date/Description	Document \$/ Line \$	Disc \$	PO #	Fund Org Acct	Object	Proj	Cash Account
129470	C	5588 FLEET CHARGE	26,789.48						
1	12/03/25	#415 INJECTOR KIT/OVERHAUL/CYL	26,056.25			6010 450200	427		101000
		X20225482301							
2	12/09/25	#262 REVIEW MIRROR	733.23			6020 450000	427		101000
		X20225508501							
		Total for Vendor:	27,259.31						
129440	C	140 FM AMBULANCE SERVICES INC	37.00						
1	12/04/25	FD E Menge BLS Heartcode	37.00			2060 415200	340		101000
		46268							
		Total for Vendor:	37.00						
129399		2637 FORCE AMERICA INC	20.00						
1	11/28/25	DATA PLAN	20.00			1000 430000	497		101000
		IN200-2009541							
		Total for Vendor:	20.00						
129477		5676 FS3 INC	5,635.52						
1	97300 11/24/25	Project 9064	5,635.52			4209 480000	670		101000
		97300							
		Total for Vendor:	5,635.52						
129356	C	155 GALLS, LLC	1,183.71						
1	11/26/25	cadets equipment	669.60			1000 421000	375		101000
		033278383							
2	11/28/25	new officer respirator - kelly	514.11			1000 421000	641		101000
		033299899							
129445	C	155 GALLS, LLC	1,104.41						
1	12/04/25	new armor vest k. kelly	1,104.41			1000 421000	641		101000
		033371842							
		Total for Vendor:	2,288.12						

* ... Over spent expenditure

Claim/ Line #	Check	Vendor #/Name/ Invoice #/Inv Date/Description	Document \$/ Line \$	Disc \$	PO #	Fund Org Acct	Object	Proj	Cash Account
129442		5659 GLOBAL INTELLIGENCE INC	2,750.00						
1	12/08/25	cybercheck case app	2,750.00			1000 421000	365		101000
295A									
		Total for Vendor:	2,750.00						
129387	C	556 GRAINGER, INC.	459.72						
1	11/25/25	DOCK BUMPER	177.14			6010 450200	420		101000
9723351061									
2	11/25/25	DUMPSTER REPAIR	282.58			6010 450200	914		101000
9723351079									
129412	C	556 GRAINGER, INC.	209.13						
1	12/05/25	DOOR STRIP	209.13			6010 450200	420		101000
9733808357									
129521	C	556 GRAINGER, INC.	1,234.59						
1	12/10/25	ENCLOSURE HEATER	839.74			6025 450000	420		101000
9737913690									
2	12/10/25	FAN MOTOR	394.85			6025 450000	420		101000
9737913682									
		Total for Vendor:	1,903.44						
129578	C	3535 GREAT PLAINS FIRE	28,942.96						
		West Fargo Fire Department 2025 Budget item							
1	12/10/25	6 sets of fire Gear-2025 Budge	28,942.96			2060 415200	641		101000
9260									
		Total for Vendor:	28,942.96						
129562		2318 HABERDASHERY	117.78						
1	27147 12/12/25	New Emp Clothing - Eng	117.78			1000 414200	422		101000
27147									
		Total for Vendor:	117.78						

* ... Over spent expenditure

Claim/ Line #	Check	Vendor #/Name/ Invoice #/Inv Date/Description	Document \$/ Line \$	Disc \$	PO #	Fund Org Acct	Object	Proj	Cash Account
129569		2713 HAMPTON INN & SUITES	440.00						
1	12/12/25	lodging, intox trn posterick	220.00			1000 421000	340		101000
83400938									
2	12/12/25	lodging, intox trn wanzek	220.00			1000 421000	340		101000
88381834									
		Total for Vendor:	440.00						
129382	C	135 HAWKINS INC	5,275.10						
1	11/25/25	AQUAHAWK	5,275.10			6025 450000	423		101000
7267816									
129543	C	135 HAWKINS INC	5,651.90						
1	12/08/25	AQUAHAWK	5,651.90			6025 450000	423		101000
7275816									
		Total for Vendor:	10,927.00						
129388	C	180 HAZER'S AUTO WRECKING	592.00						
1	12/01/25	APPLIANCE DISPOSAL	592.00			6010 450200	357		101000
4089									
		Total for Vendor:	592.00						
129343		2850 HENRY SCHEIN, INC	167.02						
1	11/21/25	medical bag supplies	167.02			1000 421000	610		101000
49955383									
		Total for Vendor:	167.02						
129337	C	1310 HERO SCHEDULE LLC	294.00						
1	12/01/25	dec 2025 active users	294.00			1000 421000	497		101000
INV-41339									
129453	C	1310 HERO SCHEDULE LLC	162.00						
1	12/01/25	FD December Scheduling Prog.	162.00			2060 415200	497		101000
41338									
		Total for Vendor:	456.00						

* ... Over spent expenditure

Claim/ Line #	Check	Vendor #/Name/ Invoice #/Inv Date/Description	Document \$/ Line \$	Disc \$	PO #	Fund Org Acct	Object	Proj	Cash Account
129501	C	4562 HMI	2,742.03						
1	10/09/25	FAST KIT	2,742.03			1000 430000	722		101000
		0051605-IN							
		Total for Vendor:	2,742.03						
129328	C	687 INFORMATION TECHNOLOGY DEPT	14,472.00						
1	11/30/25	Nov WAN/Fiber/VPN	14,472.00			1000 414104	497		101000
		DP112025.849.3							
		Total for Vendor:	14,472.00						
129489	C	4592 INGRAM LIBRARY SERVICES	2,376.36						
1	11/24/25	BOOKS	125.82			7000 411600	662		101000
		92192554							
2	11/24/25	BOOKS	15.81			7000 411600	662		101000
		92192555							
3	11/24/25	BOOKS	13.04			7000 411600	662		101000
		92192556							
4	11/24/25	BOOKS	37.69			7000 411600	662		101000
		92192557							
5	11/24/25	BOOKS	61.90			7000 411600	662		101000
		92192558							
6	11/24/25	BOOKS	14.51			7000 411600	662		101000
		92192559							
7	11/24/25	BOOKS	14.93			7000 411600	662		101000
		92192560							
8	11/24/25	BOOKS	19.92			7000 411600	662		101000
		92192561							
9	11/24/25	BOOKS	585.30			7000 411600	662		101000
		92192562							
10	11/24/25	BOOKS	22.99			7000 411600	662		101000
		92192563							
11	11/24/25	BOOKS	23.95			7000 411600	662		101000
		92192564							
12	11/24/25	BOOKS	20.95			7000 411600	662		101000
		92192565							
13	11/24/25	BOOKS	30.16			7000 411600	662		101000
		92192566							

* ... Over spent expenditure

Claim/ Line #	Check Invoice #	Vendor #/Name/ #/Inv Date/Description	Document \$/ Line \$	Disc \$	PO #	Fund Org Acct	Object	Proj	Cash Account
14	11/24/25	BOOKS	43.32			7000 411600	662		101000
92192567									
15	11/24/25	BOOKS	18.61			7000 411600	662		101000
92192568									
16	11/24/25	BOOKS	27.36			7000 411600	662		101000
92192569									
17	11/24/25	BOOKS	156.83			7000 411600	662		101000
92214493									
18	11/24/25	BOOKS	77.47			7000 411600	662		101000
92214494									
19	11/24/25	BOOKS	95.38			7000 411600	662		101000
92214495									
20	11/24/25	BOOKS	21.96			7000 411600	662		101000
92214496									
21	11/24/25	BOOKS	12.17			7000 411600	662		101000
92214497									
22	11/26/25	BOOKS	18.10			7000 411600	662		101000
92276888									
23	11/26/25	BOOKS	14.45			7000 411600	662		101000
92276889									
24	11/26/25	BOOKS	59.87			7000 411600	662		101000
92276890									
25	11/26/25	BOOKS	102.64			7000 411600	662		101000
92276891									
26	11/26/25	BOOKS	22.48			7000 411600	662		101000
92276892									
27	11/26/25	BOOKS	45.23			7000 411600	662		101000
92276893									
28	11/28/25	BOOKS	29.10			7000 411600	662		101000
92305192									
29	11/28/25	BOOKS	59.51			7000 411600	662		101000
92305193									
30	11/28/25	BOOKS	559.35			7000 411600	662		101000
92305194									
31	11/28/25	BOOKS	25.56			7000 411600	662		101000
92305195									
Total for Vendor:			2,376.36						

12/12/25
14:56:23

CITY OF WEST FARGO, ND
Claim Details by Posted Date
For Claims from 12/01/25 to 12/12/25

Page: 25 of 67
Report ID: AP100V

* ... Over spent expenditure

Claim/ Line #	Check	Vendor #/Name/ Invoice #/Inv Date/Description	Document \$/ Line \$	Disc \$	PO #	Fund Org Acct	Object	Proj	Cash Account
129340		1660 INT'L CONFERENCE OF POLICE	300.00						
1	12/11/25	2025 annual membership-vern	150.00			1000 421000	667		101000
310									
2	05/01/25	2025 annual membership-casey	150.00			1000 421000	667		101000
1580									
		Total for Vendor:	300.00						
129475		233 J & L SPORTS	568.00						
1	12/01/25	EMBROIDERY	14.00			1000 430000	422		101000
35120									
2	12/09/25	WINTER JACKET (STEVEN)	114.00			1000 430000	422		101000
35158									
3	12/09/25	WINTER JACKETS (STOCK)	440.00			6010 450200	422		101000
35158									
		Total for Vendor:	568.00						
129318		999999 J & S DEVELOPMENT	354.56						
		Overpayment Refund							
1	12/01/25	UB Refund	354.56			6020 214100			101000
		Total for Vendor:	354.56						
129474	C	1765 J.J. KELLER & ASSOC, INC	390.71						
1	12/01/25	CDL TRAINING	390.71			1000 450000	497		101000
9110728963									
		Total for Vendor:	390.71						
129315		4858 JAMES MOHR	198.51						
1	12/01/25	Work Jeans Reimbursement	198.51			1000 414200	422		101000
		clothing reimb							
		Total for Vendor:	198.51						
129352		4503 JARED JOHNSON	550.00						
1	12/04/25	clothing reimb	550.00			1000 421000	422		101000
		Total for Vendor:	550.00						

12/12/25
14:56:23

CITY OF WEST FARGO, ND
Claim Details by Posted Date
For Claims from 12/01/25 to 12/12/25

Page: 26 of 67
Report ID: AP100V

* ... Over spent expenditure

Claim/ Line #	Check Invoice #/Inv Date/Description	Vendor #/Name/ Invoice #/Inv Date/Description	Document \$/ Line \$	Disc \$	PO #	Fund Org Acct	Object	Proj	Cash Account
129353 1	12/04/25	5350 JEFFREY BOYER clothing reimb	150.50 150.50			1000 421000	422		101000
		Total for Vendor:	150.50						
129422 1	12/04/25	5325 JEREMY DOCKTER DOT TRAINING - MENDOTA HEIGHTS, MN TRAVEL REIMBURSEMENT	126.00 126.00			1000 455000	340		101000
		Total for Vendor:	126.00						
129402 1	12/02/25	C 2750 JIM'S TOWING OF FARGO #7048 TOWING	316.25 316.25			4387 480000	427		101000
		Total for Vendor:	316.25						
129391 1	12/02/25	C 2798 JOHNSON CONTROLS SHOP HEATER REPAIR	2,183.50 2,183.50			6010 450200	420		101000
		Total for Vendor:	2,183.50						
129439 1	12/01/25	C 274 JOHNSON, MOTTINGER & GREENWOOD, December 2025 Court Appointed Attorney	5,250.00 5,250.00			1000 412000	310		101000
		Total for Vendor:	5,250.00						
129590 1	01/27/25	5677 JOSEPH MAILEY Reimbursement for two paraamedic classes ACLS Course #578425	360.00 180.00			2060 415200	340		101000
		Total for Vendor:	360.00						
129527 1	12/12/2025	-95264E 4482 KOTAPAY Payroll Child Support 12/12/25	2,499.97 2,499.97			1000 212549			101000
		Total for Vendor:	2,499.97						

12/12/25
14:56:23

CITY OF WEST FARGO, ND
Claim Details by Posted Date
For Claims from 12/01/25 to 12/12/25

Page: 27 of 67
Report ID: AP100V

* ... Over spent expenditure

Claim/ Line #	Check	Vendor #/Name/ Invoice #/Inv Date/Description	Document \$/ Line \$	Disc \$	PO #	Fund Org Acct	Object	Proj	Cash Account
129548		2325 KUSTOM KONCEPTS	778.70						
1	12/09/25	DUMPSTER REPAIR	778.70			6010 450200	914		101000
1838									
		Total for Vendor:	778.70						
129481	C	5675 LAKESHORE LEARNING MATERIALS LLC	217.55						
1	12/02/25	BOARKD BOOK BIN	217.55			7000 411600	641		101000
92745265									
		Total for Vendor:	217.55						
129348		2085 LANGUAGE LINE SERVICES	189.76						
1	11/30/25	nov 2025 interpreter service	189.76			1000 421000	304		101000
11784164									
		Total for Vendor:	189.76						
129403	C	705 LAWSON PRODUCTS	754.58						
1	11/25/25	HARDWARE STOCK	754.58			1000 455000	433		101000
9313017954									
129512	C	705 LAWSON PRODUCTS	86.25						
1	12/05/25	TOP LOCK NUTS	86.25			1000 430001	381		101000
9313043023									
		Total for Vendor:	840.83						
129545	C	4767 LENOVO (UNITED STATES) INC.	859.00						
1	12/09/25	J MOLL COMPUTER	859.00			1000 455000	497		101000
6474786563									
		Total for Vendor:	859.00						
129317	C	2466 LEXIPOL LLC	14,032.45						
1	12/01/25	Annual Local Government Admin	14,032.45			1000 415000	497		101000
INVLEX11262303									
		Total for Vendor:	14,032.45						

* ... Over spent expenditure

Claim/ Line #	Check Invoice #/Inv Date/Description	Vendor #/Name/ Invoice #/Inv Date/Description	Document \$/ Line \$	Disc \$	PO #	Fund Org Acct	Object	Proj	Cash Account
129306	C	1741 LIBERTY BUSINESS SYSTEMS, INC	877.81						
2	40662857	11/25/25 Nov 2025 CH 1st Floor	34.98			1000 415000	428		101000
	40662857								
3	40662857	11/25/25 Nov 2025 City Hall	158.10			1000 415000	428		101000
	40662857								
4	40662857	11/25/25 Nov 2025 Public Works	258.23			6020 450000	428		101000
	40662857								
5	40662857	11/25/25 Nov 2025 Police	270.45			1000 421000	428		101000
	40662857								
6	40662856	11/25/25 Nov 2025 CH 1st Floor	156.05			1000 415000	428		101000
	40662856								
		Total for Vendor:	877.81						
129579		1417 LUTHER FAMILY BUICK-PONTIAC-GMC	370.23						
1	12/02/25	FD Training Pickup Tail light	370.23			2060 415200	427		101000
	423051								
		Total for Vendor:	370.23						
129454	C	3536 MACQUEEN	8,988.23						
Line #2		We Will recieve a \$2,000 credit for the Core charge.							
1	11/13/25	FD E-75 Valve,ring seat,spring	977.13			2060 415200	427		101000
	P13492								
2	11/21/25	FD E-75 steer gear slav	6,100.96			2060 415200	427		101000
	P13527								
3	11/25/25	FD E-75 Gated Wye	461.80			2060 415200	427		101000
	P58599								
4	12/01/25	FD E-76 Lights, Turn Signals	139.13			2060 415200	427		101000
	P13551								
5	12/02/25	FD E-75 Steer Filter Seal	48.35			2060 415200	427		101000
	P13554								
6	12/04/25	FD E-75 Toe Link	791.64			2060 415200	427		101000
	P13571								
7	12/05/25	FD R-75 Gauges-SCBA	186.40			2060 415200	420		101000
	P13577								
8	12/10/25	FD R-75 Replace handle	282.82			2060 415200	420		101000
	P13590								
		Total for Vendor:	8,988.23						

12/12/25
14:56:23

CITY OF WEST FARGO, ND
Claim Details by Posted Date
For Claims from 12/01/25 to 12/12/25

Page: 29 of 67
Report ID: AP100V

* ... Over spent expenditure

Claim/ Line #	Check	Vendor #/Name/ Invoice #/Inv Date/Description	Document \$/ Line \$	Disc \$	PO #	Fund Org Acct	Object	Proj	Cash Account
129466	C	1841 MACQUEEN	914.16						
1	12/02/25	EMERGENCY LIGHTS	914.16			1000 430002	870		101000
		TC10225-50							
		Total for Vendor:	914.16						
129396	C	2770 MALLOY ELECTRIC	33.30						
1	11/30/25	O RING BUNA SQUARE	33.30			6025 450000	439		101000
		6610114							
		Total for Vendor:	33.30						
129345	C	4637 MAMMOTH HOLDINGS LLC	585.00						
1	11/30/25	nov 2025 car wash	585.00			1000 421000	420		101000
		PS-INV105185							
		Total for Vendor:	585.00						
129447	C	5349 MARCO TECHNOLOGIES, LLC	262.72						
1	12/08/25	dec 2025 pd mailroom	262.72			1000 421000	428		101000
		40753112							
129484	C	5349 MARCO TECHNOLOGIES, LLC	714.62						
1	11/27/25	LEASE FOR PRINTERS	714.62			7000 411600	428		101000
		40682692							
129537	C	5349 MARCO TECHNOLOGIES, LLC	2,201.60						
1	40753111	12/08/25 Finance	212.65			1000 414100	428		101000
		40753111							
2	40753111	12/08/25 Non-Departmental	897.54			1000 415000	428		101000
		40753111							
3	40753111	12/08/25 Planning / Inspections	117.36			1000 418000	428		101000
		40753111							
4	40753111	12/08/25 HR	36.32			1000 414103	428		101000
		40753111							
5	40753111	12/08/25 Court	240.43			1000 412000	428		101000
		40753111							
6	40753111	12/08/25 Police	25.76			1000 421000	428		101000
		40753111							

12/12/25
14:56:23

CITY OF WEST FARGO, ND
Claim Details by Posted Date
For Claims from 12/01/25 to 12/12/25

Page: 30 of 67
Report ID: AP100V

* ... Over spent expenditure

Claim/ Line #	Check Invoice #	Vendor #/Name/ Inv Date/Description	Document \$/ Line \$	Disc \$	PO #	Fund Org Acct	Object	Proj	Cash Account
7	40753111	12/08/25 PW Water	184.56			6020 450000	428		101000
40753111									
8	40753111	12/08/25 PW Sanitation	162.61			6010 450200	428		101000
40753111									
9	40753111	12/08/25 Fire	54.46			2060 415200	428		101000
40753111									
10	40753111	12/08/25 IT	117.36			1000 414104	428		101000
40753111									
11	40753111	12/08/25 Fleet & Facilities	35.19			1000 455000	428		101000
40753111									
12	40753111	12/08/25 Admin	117.36			1000 414000	428		101000
40753111									
129574	C	5349 MARCO TECHNOLOGIES, LLC	67.69						
1	12/08/25	nov 2025 pd training room	67.69			1000 421000	428		101000
40753113									
		Total for Vendor:	3,246.63						
129400		3384 MATHESON TRI-GAS INC	467.30						
1	11/26/25	CO2	75.48			6020 450000	433		101000
0032447206									
2	12/03/25	NITRIC OXIDE BAL NIT.	391.82			1000 455000	420		101000
0032472957									
		Total for Vendor:	467.30						
129533		3119 MATT RETKA	50.00						
1	12/10/25	Dec WF Airport Secretary	50.00			7050 500000	120		101000
		Total for Vendor:	50.00						
129580	C	299 MENARDS (FIRE)	113.34						
1	12/02/25	FD I-2 remote batteries	12.95			2060 415200	500		101000
70678									
2	11/25/25	FD Install Lock Boxes	78.73			2060 415200	494		101000
70231									
3	11/25/25	FD Misc Hardware	21.66			2060 415200	500		101000
70231									
		Total for Vendor:	113.34						

12/12/25
14:56:23

CITY OF WEST FARGO, ND
Claim Details by Posted Date
For Claims from 12/01/25 to 12/12/25

Page: 31 of 67
Report ID: AP100V

* ... Over spent expenditure

Claim/ Line #	Check Invoice #/Inv Date/Description	Vendor #/Name/ Invoice #/Inv Date/Description	Document \$/ Line \$	Disc \$	PO #	Fund Org Acct	Object	Proj	Cash Account
129372	C	4622 MENARDS (PUBLIC WORKS)	396.71						
1	11/26/25	PVC CLEANOUT PLUG	3.92			6020 450000	433		101000
70295									
2	12/03/25	CLEANOUT PLUGS/WIRE BRUSH	72.31			6025 450000	439		101000
70743									
3	12/03/25	ULT SEAL	15.98			6025 450000	423		101000
70765									
4	12/01/25	WIRE BRUSHES	22.93			6025 450000	432		101000
70598									
5	12/02/25	MARKING FLAGS	9.99			1000 430000	432		101000
70661									
6	12/02/25	ICE SCRAPERS	35.94			1000 455000	433		101000
70656									
7	12/01/25	PLUNGERS	28.43			1000 455000	420		101000
70600									
8	11/26/25	MOUSE TRAPS	11.53			6020 450000	420		101000
70329									
9	11/24/25	MOUSE BAIT	27.99			6020 450000	420		101000
70176									
10	12/02/25	MOUSE TRAPS	11.80			6020 450000	420		101000
70651									
11	12/03/25	CABLE TIES	12.48			1000 455000	420		101000
70742									
12	11/24/25	SAND TUBES	115.68			6010 450200	420		101000
70160									
13	12/04/25	LUMBER	27.73			1000 455000	802		101000
70824									
129376	C	4622 MENARDS (PUBLIC WORKS)	4.98						
1	12/04/25	REFLECT NUMBER KIT	4.98			1000 430000	432		101000
70813									
129380	C	4622 MENARDS (PUBLIC WORKS)	18.83						
1	12/04/25	CLEANING SUPPLIES	18.83			6025 450000	432		101000
70820									

12/12/25
14:56:23

CITY OF WEST FARGO, ND
Claim Details by Posted Date
For Claims from 12/01/25 to 12/12/25

Page: 32 of 67
Report ID: AP100V

* ... Over spent expenditure

Claim/ Line #	Check	Vendor #/Name/ Invoice #/Inv Date/Description	Document \$/ Line \$	Disc \$	PO #	Fund Org Acct	Object	Proj	Cash Account
129411	C	4622 MENARDS (PUBLIC WORKS)	102.36						
1	12/05/25	COVERALLS	69.99			6010 450200	422		101000
70919									
2	12/01/25	HAND/FOOT WARMERS	32.37			6010 450200	422		101000
70602									
129546	C	4622 MENARDS (PUBLIC WORKS)	185.06						
1	12/11/25	WD40/CLEANER	185.06			6010 450200	422		101000
71304									
		Total for Vendor:	707.94						
129373	C	2489 MENARDS-MOORHEAD	152.25						
1	10/28/25	LFFBV-3 PRESS/BUSHING/ELBOW	152.25			6020 450000	432		101000
24357									
		Total for Vendor:	152.25						
129557	E	2766 MIDCONTINENT COMMUNICATIONS	605.05						
1	12/11/25	TS INTERNET (AUG-DEC)	605.05			6010 450200	497		101000
119329801									
		Total for Vendor:	605.05						
129555	C	102 MIDSTATES WIRELESS	718.71						
1	12/08/25	#2101 RADIO INSTALL	718.71			6020 450000	610		101000
308000214-1									
129573	C	102 MIDSTATES WIRELESS	142.50						
1	12/11/25	#1175 replace handle	142.50			1000 421000	427		101000
207001094-1									
		Total for Vendor:	861.21						
129491	C	1854 MIDWEST TAPE	3,212.44						
1	10/22/25	DVD	30.72			7000 411600	664		101000
507915713									
2	10/22/25	DVD	23.97			7000 411600	664		101000
507915714									
3	10/22/25	DVD	141.60			7000 411600	664		101000
507915716									

* ... Over spent expenditure

Claim/ Line #	Check Invoice #/Inv Date/Description	Vendor #/Name/ #/Inv Date/Description	Document \$/ Line \$	Disc \$	PO #	Fund Org Acct	Object	Proj	Cash Account
4	10/28/25 DVD		43.29			7000 411600	664		101000
507951164									
5	10/28/25 DVD		74.16			7000 411600	664		101000
507951160									
6	10/28/25 DVD		165.61			7000 411600	664		101000
507951161									
7	10/28/25 DVD		103.80			7000 411600	664		101000
507951163									
8	11/04/25 DVD		23.97			7000 411600	664		101000
507984194									
9	11/04/25 DVD		112.35			7000 411600	664		101000
507984195									
10	11/04/25 DVD		171.65			7000 411600	664		101000
507984196									
11	11/04/25 DVD		56.94			7000 411600	664		101000
507984197									
12	11/04/25 DVD		197.42			7000 411600	664		101000
507984198									
13	11/12/25 DVD		155.02			7000 411600	664		101000
50819125									
14	11/12/25 DVD		355.35			7000 411600	664		101000
508019123									
15	11/12/25 DVD		195.63			7000 411600	664		101000
508019126									
16	11/12/25 DVD		165.78			7000 411600	664		101000
508019127									
17	11/12/25 DVD		80.91			7000 411600	664		101000
508019128									
18	11/19/25 DVD		75.57			7000 411600	664		101000
508052551									
19	11/19/25 DVD		66.45			7000 411600	664		101000
508052552									
20	11/19/25 DVD		74.07			7000 411600	664		101000
508052469									
21	11/19/25 DVD		182.16			7000 411600	664		101000
508052466									
22	11/19/25 DVD		143.10			7000 411600	664		101000
508052468									

* ... Over spent expenditure

Claim/ Line #	Check Invoice #/Inv Date/Description	Vendor #/Name/ Invoice #/Inv Date/Description	Document \$/ Line \$	Disc \$	PO #	Fund Org Acct	Object	Proj	Cash Account
23	11/19/25 DVD		98.88			7000 411600	664		101000
508052550									
24	11/25/25 DVD		71.54			7000 411600	664		101000
508082435									
25	11/25/25 DVD		70.04			7000 411600	664		101000
508082436									
26	11/25/25 DVD		98.88			7000 411600	664		101000
508082437									
27	12/02/25 DVD		55.44			7000 411600	664		101000
508113233									
28	12/02/25 DVD		66.56			7000 411600	664		101000
508113232									
29	12/09/25 DVD		72.64			7000 411600	664		101000
508149407									
30	12/09/25 DVD		38.94			7000 411600	664		101000
508149405									
31	DVD		0.00			7000 411600	664		101000
		Total for Vendor:	3,212.44						
129354		908 MILES ORTH	514.95						
1	12/04/25 clothing reimb		514.95			1000 421000	422		101000
		Total for Vendor:	514.95						
129326	C	305 MOORE ENGINEERING INC	375,740.67						
1	SIN006100 11/17/25 Floodplain Support Services		161.25			1000 414200	313		101000
SIN006100									
2	SIN006102 11/18/25 Imp Dist No 1339		575.25			4088 480000	313		101000
SIN006102									
3	SIN006259 11/25/25 W.F. Imp Dist No 1345		10,012.64			4009 480000	313		101000
SIN006259									
4	SIN006255 11/25/25 Imp Dist No 1348		11,157.61			4444 480000	313		101000
SIN006255									
5	SIN006339 11/26/25 Project 1351		3,643.95			4221 480000	313		101000
SIN006339									
6	SIN006270 11/25/25 Project 1352		2,902.50			4222 480000	313		101000
SIN006270									
7	SIN006326 11/25/25 Dist 1353		23,079.73			4189 480000	313		101000
SIN006326									

* ... Over spent expenditure

Claim/ Line #	Check	Vendor #/Name/ Invoice #/Inv Date/Description	Document \$/ Line \$	Disc \$	PO #	Fund Org Acct	Object	Proj	Cash Account
8	SIN006325	11/25/25 Imp Dist No 2288	15,466.20			4437 480000	313		101000
	SIN006325								
9	SIN006269	11/25/25 Dist 2296	7,114.25			4191 480000	313		101000
	SIN006269								
10	SIN006261	11/25/25 Dist 2297	8,421.50			4192 480000	313		101000
	SIN006261								
11	SIN006327	11/25/25 W.F. Imp Dist No 3006	65,841.64			4003 480000	313		101000
	SIN006327								
12	SIN006351	11/26/25 Dist 3008	47,585.37			4224 480000	313		101000
	SIN006351								
13	SIN006350	11/26/25 Dist 3009	26,306.28			4225 480000	313		101000
	SIN006350								
14	SIN006340	11/26/25 Project 9021	49,396.00			2970 480000	313		101000
	SIN006340								
15	SIN006130	11/20/25 Project 9033	1,861.00			6010 450200	313		101000
	SIN006130								
16	SIN006129	11/20/25 Project 9063	98,260.75			4227 480000	313		101000
	SIN006129								
17	SIN006323	11/25/25 Public Works Faciltlity Expa	3,954.75			4188 480000	313		101000
	SIN006323								
Total for Vendor:			375,740.67						
129342	C	688 MOTOROLA SOLUTIONS, INC	50.00						
1	12/01/25	power kit	50.00			1000 421000	641		101000
	1187161907								
Total for Vendor:			50.00						
129499	C	298 MVTL LABORATORIES	1,312.25						
1	12/04/25	WATER TESTING	1,312.25			6025 450000	335		101000
	1336472								
Total for Vendor:			1,312.25						
129363	C	728 NAPA CENTRAL	2,265.05						
1	11/26/25	SHOP SUPPLIES	330.06			1000 455000	433		101000
	497444								
2	11/26/25	M1VXOW40	611.96			1000 421000	424		101000
	497446								

* ... Over spent expenditure

Claim/ Line #	Check Invoice #/Inv Date/Description	Vendor #/Name/ #/Inv Date/Description	Document \$/ Line \$	Disc \$	PO #	Fund Org Acct	Object	Proj	Cash Account
3 497445	11/26/25 REFRIGERANT		444.99			1000 421000	427		101000
4 497441	11/26/25 OIL DRY		599.25			1000 430000	433		101000
5 497448	11/26/25 ATD TS508WF TOOL		278.79			1000 455000	432		101000
		Total for Vendor:	2,265.05						
129464		3428 ND DEPARTMENT OF ENVIRONMENTAL	734.08						
1 202510.078400	10/15/25 WATER TESTING		734.08			6020 450000	335		101000
		Total for Vendor:	734.08						
129558		335 ND DEPT OF TRANSPORTATION	7,859.44						
1 0002594810	0002594810 12/02/25 Project 2279		5,585.46			4802 480000	670		101000
2 0002594811	0002594811 12/02/25 Project 2279		1,802.00			4802 480000	670		101000
3 0002594812	0002594812 12/02/25 Project 6058		471.98			4019 480000	670		101000
		Total for Vendor:	7,859.44						
129321	-95269E 363 ND PERS		369.16						
	November 2025 - Adjustment								
1	12/03/25 Retro Pay Adjust		369.17			1000 212532			101000
2	12/03/25 Rounding		-0.01			1000 414100	230		101000
129529	-95262E 363 ND PERS		9,811.50						
	12/12/25 Payroll								
1	12/12/25 457b Def Comp - Contributions		9,811.50			1000 212532			101000
		Total for Vendor:	10,180.66						
129311	C 2261 NETWORK CENTER INCORPORATED		7,537.60						
	Office 365 G1 - 169 licenses								
	Office 365 G3 - 229 licenses								
	MS Teams Rooms Pro - 10 licenses								
	Power BI Pro - 1 license								
	Office 365 G5 - 2 licenses								
	Teams Phone - 1 license								

12/12/25
14:56:23

CITY OF WEST FARGO, ND
Claim Details by Posted Date
For Claims from 12/01/25 to 12/12/25

Page: 37 of 67
Report ID: AP100V

* ... Over spent expenditure

Claim/ Line #	Check Invoice #	Vendor #/Name/ Inv Date/Description	Document \$/ Line \$	Disc \$	PO #	Fund	Org	Acct	Object	Proj	Cash Account
1	INV242459	12/01/25 Microsoft 365 Subscriptions	7,537.60			1000		414104	497		101000
129323	C	2261 NETWORK CENTER INCORPORATED	72,833.38								
1	INV242670	12/03/25 NCI Shipping & Handling	126.95			1000		414104	497		101000
2	INV242670	12/03/25 Pure Storage Datapack	67,058.82			1000		414104	497		101000
3	INV242670	12/03/25 Evergree monthly subscrip	577.16			1000		414104	497		101000
4	INV242670	12/03/25 Remote Install FA Capacity	5,070.45			1000		414104	497		101000
129492	C	2261 NETWORK CENTER INCORPORATED	799.30								
1	INV242741	12/05/25 IP Phone / Mounting Bracket	799.30			1000		414104	497		101000
Total for Vendor:			81,170.28								
129581		3094 NFPA (NATIONAL FIRE PROTECTION Dell Sprecher NFPA #362368 2026 Renewal	225.00								
1		11/19/25 D Sprecher NFPA #362368 362368 Sprecher	225.00			2060		415200	667		101000
Total for Vendor:			225.00								
129397	C	370 NORTH DAKOTA SAFETY COUNCIL	740.00								
1		11/25/25 CONFINED SPACE ENTRY TRAINING 161891	740.00			6025		450000	340		101000
129421	C	370 NORTH DAKOTA SAFETY COUNCIL	395.00								
1		2026 MEMBERSHIP	395.00			1000		450000	667		101000
Total for Vendor:			1,135.00								
129514	C	5240 NORTHERN ENGINE & SUPPLY	8.56								
1		12/05/25 #4100 TEE FITTING 271973	8.56			6010		450200	427		101000
Total for Vendor:			8.56								

12/12/25
14:56:23

CITY OF WEST FARGO, ND
Claim Details by Posted Date
For Claims from 12/01/25 to 12/12/25

Page: 38 of 67
Report ID: AP100V

* ... Over spent expenditure

Claim/ Line #	Check	Vendor #/Name/ Invoice #/Inv Date/Description	Document \$/ Line \$	Disc \$	PO #	Fund Org Acct	Object	Proj	Cash Account
129500		3111 NORTHERN SALT INCORPORATED	29,096.64						
1	12/04/25	BULK DE-ICING SALT	29,096.64			1000 430000	377		101000
33678									
		Total for Vendor:	29,096.64						
129367	C	1715 NORTHWEST TIRE INC	1,741.34						
1	12/02/25	#4009 FLAT REPAIR	73.23			6010 450200	427		101000
24053719									
2	11/24/25	#4301 TIRES	1,668.11			6010 450200	427		101000
24053584									
129538	C	1715 NORTHWEST TIRE INC	17.86						
1	26061003	12/11/25 Tire Repair - IT	17.86			1000 414104	424		101000
26061003									
129582	C	1715 NORTHWEST TIRE INC	960.03						
1	12/06/25	FD T-76 Flat Repair	73.23			2060 415200	420		101000
24053835									
2	12/09/25	FD T-76 New Tire	886.80			2060 415200	420		101000
24053882									
		Total for Vendor:	2,719.23						
129339	C	5440 NORTHWEST TIRE INC. (PD)	43.51						
1	12/03/25	#1208 tire repair	43.51			1000 421000	427		101000
26060809									
129448	C	5440 NORTHWEST TIRE INC. (PD)	868.06						
1	12/09/25	#1226 tire repair	43.51			1000 421000	427		101000
26060932									
2	12/09/25	#164 tires	824.55			1000 421000	427		101000
26060931									
129572	C	5440 NORTHWEST TIRE INC. (PD)	157.95						
1	12/11/25	#158 install rims	157.95			1000 421000	427		101000
26061011									
		Total for Vendor:	1,069.52						

12/12/25
14:56:23

CITY OF WEST FARGO, ND
Claim Details by Posted Date
For Claims from 12/01/25 to 12/12/25

Page: 39 of 67
Report ID: AP100V

* ... Over spent expenditure

Claim/ Line #	Check	Vendor #/Name/ Invoice #/Inv Date/Description	Document \$/ Line \$	Disc \$	PO #	Fund Org Acct	Object	Proj	Cash Account
129413	C	330 NORTHWESTERN EQUIPMENT INC.	87.70						
1	11/06/25	HOOK & THIMBLE	87.70			6010 450200	427		101000
55795									
		Total for Vendor:	87.70						
129407		5077 NOTT COMPANY	410.30						
1	11/25/25	#3062 BEARING KIT	410.30			1000 430000	427		101000
5353571									
		Total for Vendor:	410.30						
129304	C	5603 NUWAVE COMMUNICATIONS INC	1,975.53						
1	143144 12/01/25	MS Teams phone plan - Dec 25	1,975.53			1000 414104	497		101000
143144									
		Total for Vendor:	1,975.53						
129583		1774 O'REILLY AUTOMOTIVE STORES, INC	43.17						
1	12/09/25	FD T-75 Replace Wipers	82.38			2060 415200	420		101000
1932-124954									
2	12/10/25	FD T-75 Return Wrong Wiper	-39.21			2060 415200	420		101000
1932-125245									
		Total for Vendor:	43.17						
129366		4744 O'REILLY AUTOMOTIVE STORES, INC	239.86						
1	12/02/25	#8011 BATTERY	158.24			1000 415000	427		101000
1932122532									
2	11/26/25	WSHR NOZZLE	13.43			1000 430001	427		101000
1932121160									
3	12/04/25	#1204 PURGE VALVE	68.19			1000 421000	427		101000
1932123482									
129509		4744 O'REILLY AUTOMOTIVE STORES, INC	686.45						
1	12/09/25	#8012 OESPECTRUM/DOOR LCK ACT	192.91			1000 415000	427		101000
1932125076									
2	12/10/25	#380 THREADED ROD	8.60			1000 430000	427		101000
1932125373									
3	12/10/25	#380 BATT TERM	9.49			1000 430000	427		101000
1932125432									

* ... Over spent expenditure

Claim/ Line #	Check Invoice #/Inv Date/Description	Vendor #/Name/ #/Inv Date/Description	Document \$/ Line \$	Disc \$	PO #	Fund Org Acct	Object	Proj	Cash Account
4	12/10/25 #380 BATTERY		376.56			1000 430000	427		101000
	1932125233								
5	12/09/25 WIPER BLADES		98.89			1000 421000	427		101000
	1932124962								
129551		4744 O'REILLY AUTOMOTIVE STORES, INC	245.99						
1	12/09/25 BATTERY		245.99			1000 430001	427		101000
	1932124961								
		Total for Vendor:	1,172.30						
129567	C	353 OHNSTAD TWICHELL	80,006.08						
		November invoices							
2	11/21/25 Imp Dist 2296		84.00			4191 480000	312		101000
	209132								
3	11/21/25 Imp Dist 2297		84.00			4192 480000	312		101000
	209133								
5	11/21/25 Public Obstruction Ordinance		605.00			1000 415000	312		101000
	209137								
7	11/21/25 Project 9061		8,500.00			4188 480000	312		101000
	209135								
8	11/21/25 Project 9061		4,000.00			4188 480000	312		101000
	209135								
14	10/31/25 Municipal Prosecutions		43,031.16			1000 412000	312		101000
	209158								
19	11/21/25 Code Amendments		108.00			1000 418000	312		101000
	209138								
20	11/21/25 Municipal Judge Ordinance		1,590.00			1000 412000	312		101000
	209139								
49	11/21/25 Imp Dist 1356		88.00			4197 480000	312		101000
	209140								
50	11/21/25 AT&T Tower Lease Agreements		84.00			1000 415000	312		101000
	209155								
51	11/21/25 Project 6060		1,842.00			4098 480000	312		101000
	209142								
52	11/21/25 Hope Lutheran Addition		294.00			1000 418000	312		101000
	209143								
62	11/21/25 General		6,145.50			1000 415000	312		101000
	209147								

* ... Over spent expenditure

Claim/ Line #	Check Invoice #/Inv Date/Description	Vendor #/Name/ Invoice #/Inv Date/Description	Document \$/ Line \$	Disc \$	PO #	Fund Org Acct	Object	Proj	Cash Account
63 209144	11/21/25 Rezone Hope Lutheran Addition		111.00			1000 418000	312		101000
64 209145	11/21/25 Imp Dist 2290		546.00			4185 480000	312		101000
66 209146	11/21/25 Open Records Requests		661.50			1000 415000	312		101000
67 209148	11/21/25 Personnel Issues		8,778.00			1000 414103	312		101000
68 209149	11/21/25 Water Services Agreement		462.00			1000 415000	312		101000
69 209150	11/21/25 Short Term Rentals Ordinance		743.36			1000 415000	312		101000
70 209152	11/21/25 Project 1351		84.00			4221 480000	312		101000
71 209153	11/21/25 Project 2293		84.00			4187 480000	312		101000
72 209151	11/21/25 Imp Dist 2294		1,008.00			4223 480000	312		101000
73 209156	11/21/25 Imp Dist 3008		84.00			4224 480000	312		101000
74 209157	11/21/25 Imp Dist 3009		84.00			4225 480000	312		101000
81 209154	11/21/25 Flood Insurance Rate Map Ord		432.00			1000 415000	312		101000
82 209134	11/21/25 Landscaping Ordinance		472.56			1000 415000	312		101000
		Total for Vendor:	80,006.08						
129553	C 352 OK TIRE STORE - COM CTR		796.79						
1 05-382513	12/11/25 #2100 TIRES		796.79			6020 450000	427		101000
		Total for Vendor:	796.79						
129503	399 OLYMPIC SALES		133.26						
1 16177	12/04/25 DUMPSTER REPAIR		69.50			6010 450200	914		101000
2 16091	12/04/25 413 HOR MAST CYLIND KIT		63.76			6010 450200	427		101000

* ... Over spent expenditure

Claim/ Line #	Check Invoice #/Inv Date/Description	Vendor #/Name/ Invoice #/Inv Date/Description	Document \$/ Line \$	Disc \$	PO #	Fund Org Acct	Object	Proj	Cash Account
129549		399 OLYMPIC SALES	3,990.00						
1	12/10/25	6YD REARLOAD DUMPSTER X2	3,990.00			6010 450200	665		101000
16186									
		Total for Vendor:	4,123.26						
129490	C	631 ONE CALL CONCEPTS, INC	328.50						
1	5114272 11/30/25	Nov 2025 Locates	328.50			6020 450000	412		101000
5114272									
		Total for Vendor:	328.50						
128875		276 OSTROMS ACE HARDWARE	355.85						
1	11/06/25	DT room, cleaning	135.97			1000 421000	641		101000
229855									
2	11/06/25	windshield wash	79.90			1000 421000	641		101000
229855									
3	11/06/25	K9 food	139.98			1000 421000	915		101000
229855									
129584		276 OSTROMS ACE HARDWARE	4.36						
1	11/12/25	FD Misc Hardware	4.36			2060 415200	420		101000
229886									
		Total for Vendor:	360.21						
129360		5119 OSTROMS ACE HARDWARE (PW)	396.52						
1	10/29/25	SOCKET SET	334.98			6010 450200	641		101000
229809									
2	11/06/25	SPRAY PAINT	7.99			6025 450000	432		101000
229858									
3	11/18/25	BLADES/UTILITY KNIFE	28.57			6020 450000	433		101000
229907									
4	11/06/25	PVC ELBOW	12.99			6010 450200	433		101000
229853									
5	11/21/25	GFCI COVER	11.99			6010 450200	420		101000
229917									
		Total for Vendor:	396.52						

12/12/25
14:56:23

CITY OF WEST FARGO, ND
Claim Details by Posted Date
For Claims from 12/01/25 to 12/12/25

Page: 43 of 67
Report ID: AP100V

* ... Over spent expenditure

Claim/ Line #	Check	Vendor #/Name/ Invoice #/Inv Date/Description	Document \$/ Line \$	Disc \$	PO #	Fund Org Acct	Object	Proj	Cash Account
129482	C	2126 OVERDRIVE, INC	10,202.98						
1	11/26/25	EBOOKS/AUDIOBOOKS	2,546.76			7000 411600	650		101000
		02139CO25372719							
2	11/03/25	EBOOKS/AUDIOBOOKS	1,614.23			7000 411600	650		101000
		02139CO25346106							
3	12/05/25	EBOOKS/AUDIOBOOKS	6,041.99			7000 411600	662		101000
		02139CO25386526							
		Total for Vendor:	10,202.98						
129389	C	1648 PARKLAND USA CORPORATION DBA	57,281.14						
1	11/27/25	87 ETHANOL - PW	15,217.74			1000 140000			101000
		IN-985101-25							
2	11/26/25	DIESEL - PW	20,378.97			1000 140000			101000
		IN-989568-25							
3	11/21/25	DIESEL - 40TH AVE	21,684.43			1000 140000			101000
		IN-989567-25							
129510	C	1648 PARKLAND USA CORPORATION DBA	298.99						
1	12/09/25	RIDGELINE DEF	298.99			1000 430000	424		101000
		IN-001290-25							
		Total for Vendor:	57,580.13						
129338		4722 PASSPORT LABS INC	23,300.00						
		1/1/2025 to 12/31/25							
1	12/02/25	annual fee	23,300.00			1000 421000	497		101000
		INV-1056909							
		Total for Vendor:	23,300.00						
129398	C	563 PETRO SERVE USA	649.00						
1	12/01/25	OIL PUMP	649.00			1000 455000	433		101000
		100273							
129517	C	563 PETRO SERVE USA	133.48						
1	12/10/25	#2006 DIESEL	133.48			6020 450000	424		101000
		4958							

12/12/25
14:56:23

CITY OF WEST FARGO, ND
Claim Details by Posted Date
For Claims from 12/01/25 to 12/12/25

Page: 44 of 67
Report ID: AP100V

* ... Over spent expenditure

Claim/ Line #	Check	Vendor #/Name/ Invoice #/Inv Date/Description	Document \$/ Line \$	Disc \$	PO #	Fund Org Acct	Object	Proj	Cash Account
129532	C	563 PETRO SERVE USA	4,503.28						
1	0967933	11 11/30/25 WF Airport Fuel	4,503.28			7050 500000	424		101000
	0967933	11/25							
129585	C	563 PETRO SERVE USA	79.80						
1	11/10/25	FD Generator Gas Can	44.46			2060 415200	424		101000
29363									
2	10/22/25	FD Propane	35.34			2060 415200	424		101000
St 76									
		Total for Vendor:	5,365.56						
129586		1987 PETSMART	309.95						
1	12/02/25	FD K-9 Mika	309.95			2060 415200	915		101000
807687									
		Total for Vendor:	309.95						
129525	C	1483 PITNEY BOWES BANK INC - RESERVE	1,500.00						
		City Hall postage machine - meter refill							
1	12/09/25	Reserve Acct 20613972	1,500.00			1000 415000	661		101000
129547	C	1483 PITNEY BOWES BANK INC - RESERVE	1,000.00						
1	12/12/25	POSTAGE REFILL	1,000.00			7000 411600	661		101000
ACCT#43560960									
		Total for Vendor:	2,500.00						
129485	C	384 PITNEY BOWES GLOBAL FINANCIAL	231.00						
1	12/05/25	LEASE FOR SHIPPING CUBE	231.00			7000 411600	428		101000
0017270315									
		Total for Vendor:	231.00						
129487		4792 PLAYAWAY PRODUCTS	3,194.81						
1	12/03/25	BOOKS	3,194.81			7000 411600	662		101000
518854									
		Total for Vendor:	3,194.81						

* ... Over spent expenditure

Claim/ Line #	Check	Vendor #/Name/ Invoice #/Inv Date/Description	Document \$/ Line \$	Disc \$	PO #	Fund Org Acct	Object	Proj	Cash Account
129386	C	5431 PLOWOPS INC	2,040.00						
1	12/01/25	PLOWOPS SUBSCRIPTION (DEC)	2,040.00			1000 430000	497		101000
04774									
		Total for Vendor:	2,040.00						
129542		4064 POMP'S TIRE SERVICE (ROYAL TIRE)	1,249.80						
1	11/18/25	#4021 FLAT REPAIR	42.80			6010 450200	427		101000
2450014010									
2	11/11/25	#4006 TIRES	1,207.00			6010 450200	427		101000
2450013881									
		Total for Vendor:	1,249.80						
129357	C	3391 PPI CONSULTING LLC	475.00						
1	12/05/25	psych assessment	475.00			1000 421000	399		101000
25-243									
		Total for Vendor:	475.00						
129424	C	1755 PRO SWEEP INC	1,700.00						
1	11/25/25	SHEYENE TUNNEL SWEEP (NOV)	1,700.00			1000 430000	485		101000
27060									
		Total for Vendor:	1,700.00						
129541		2982 RDO EQUIPMENT CO	629.08						
1	12/11/25	#7706 FILTER HEAD/ELEMENT	629.08			6025 450000	427		101000
P4767454									
		Total for Vendor:	629.08						
129361		3893 RDO TRUCK CENTERS	375.68						
1	12/03/25	#7043 WINDOW REGULATOR	375.68			4387 480000	427		101000
842167F									
2	11/25/25	#7043 WINDOW REGULATOR	375.68			4387 480000	427		101000
842131F									
3	11/25/25	RETURN	-375.68			4387 480000	427		101000
CM842131F									

12/12/25
14:56:23

CITY OF WEST FARGO, ND
Claim Details by Posted Date
For Claims from 12/01/25 to 12/12/25

Page: 46 of 67
Report ID: AP100V

* ... Over spent expenditure

Claim/ Line #	Check Invoice #/Inv Date/Description	Vendor #/Name/ Invoice #/Inv Date/Description	Document \$/ Line \$	Disc \$	PO #	Fund Org Acct	Object	Proj	Cash Account
129505		3893 RDO TRUCK CENTERS	54.90						
1	12/05/25	#7042 BELT	54.90			4387 480000	427		101000
	842622F								
		Total for Vendor:	430.58						
129329	C	3204 RECORD KEEPERS	35.00						
1	A289649 11/30/25	City Hall / Court Shred Bins	35.00			1000 415000	420		101000
	A289649								
		Total for Vendor:	35.00						
129588	E	1881 SAM'S CLUB/SYNCHRONY BANK (FD)	468.72						
1	12/01/25	FD St 75 Supplies	40.94			2060 415200	500		101000
	2025								
2	12/01/25	FD St 76 Supplies	427.78			2060 415200	500		101000
	2025								
		Total for Vendor:	468.72						
129463	C	437 SANDY'S DONUTS & COFFEE SHOP	992.27						
1	#15 12/04/25	Enterprise Grant	992.27			2960 411900	654		101000
	#15								
		Total for Vendor:	992.27						
129378	C	454 SANITATION PRODUCTS	271.69						
1	12/01/25	VACTOR - PLUG ASSY	271.69			6025 450000	427		101000
	95130								
129471	C	454 SANITATION PRODUCTS	584.96						
1	12/08/25	#7001 FILTER	352.64			6025 450000	427		101000
	95184								
2	12/08/25	#7001 FILTER	232.32			6025 450000	427		101000
	95189								
		Total for Vendor:	856.65						

* ... Over spent expenditure

Claim/ Line #	Check	Vendor #/Name/ Invoice #/Inv Date/Description	Document \$/ Line \$	Disc \$	PO #	Fund Org Acct	Object	Proj	Cash Account
129561	C	2602 SELLIN BROTHERS, INC	366,584.63						
1	Pay App 8	12/05/25 Project 3006	366,584.63			4003 480000	670		101000
	Pay App 8								
		Total for Vendor:	366,584.63						
129438	-95266E	5570 SHEYENNE 32 EAST LLC	699.67						
3150	Sheyenne St - Unit A								
1	Dec 2025	12/01/25 CAM/Operating Exp - Nov	484.00			2960 411900	416		101000
3150	Sheyenne St - Unit A								
2	Dec 2025	12/01/25 Parking Fee - Nov	79.17			2960 411900	416		101000
3150	Sheyenne St - Unit A								
3	Dec 2025	12/01/25 Plaza Fee - Nov	136.50			2960 411900	416		101000
3150	Sheyenne St - Unit A								
		Total for Vendor:	699.67						
129589	C	2885 SHORTPRINTER	230.03						
1	11/25/25	FD 25 Awards Ceremoney handout	65.00			2060 415200	378		101000
167992									
2	12/02/25	FD 25 Christmas Cards	165.03			2060 415200	378		101000
168220									
		Total for Vendor:	230.03						
129374	C	91 SIGN SOLUTIONS USA	1,881.46						
1	11/26/25	SIGNS	1,881.46			1000 430000	377		101000
420618									
		Total for Vendor:	1,881.46						
129309		2655 SIMPLIFILE	120.00						
1	11/30/25	Service 11/01/25-11/30/25	120.00			1000 418000	668		101000
NDT8B3-11302025									
		Total for Vendor:	120.00						
129305	C	3528 SNACKS PLUS VENDING	520.00						
1	5940953032	10/06/25 Coffee for City Hall	520.00			1000 415000	420		101000
5940953032									

* ... Over spent expenditure

Claim/ Line #	Check	Vendor #/Name/ Invoice #/Inv Date/Description	Document \$/ Line \$	Disc \$	PO #	Fund Org Acct	Object	Proj	Cash Account
129416	C	3528 SNACKS PLUS VENDING	64.00						
1	12/03/25	COFFEE	64.00			6020 450000	500		101000
		5940:1007836							
Total for Vendor:			584.00						
129406	C	3652 SNAP-ON TOOLS INDUSTRIAL	33.71						
1	11/26/25	IMP SKIT	33.71			1000 455000	432		101000
		ARV/66507896							
Total for Vendor:			33.71						
129316		5600 SOUTHDATA INC	12,399.39						
1	994694595	11/30/25 UB Statements/Postage - Nov	12,299.39			6020 450000	360		101000
		994694595							
2	994694594	11/30/25 NCOA Link	100.00			6020 450000	360		101000
		994694594							
Total for Vendor:			12,399.39						
129587	C	465 SPARTAN STORES LLC	11.98						
1	12/05/25	FD Academy Graduation	11.98			2060 415200	378		101000
		469384							
Total for Vendor:			11.98						
129377	C	176 SUMMIT FIRE PROTECTION	2,595.80						
1	12/08/25	ANNUAL ALARM INSPECT - 40TH AV	253.00			6020 450000	420		101000
		3704317							
3	11/29/25	ANNUAL ALARM INSPECT - SANIT	247.00			6010 450200	420		101000
		3681935							
4	11/29/25	ANNUAL ALARM INSPECT- PW	647.00			6020 450000	420		101000
		3681932							
5	11/26/25	ANNUAL ALARM INSPECT - TS	411.00			6010 450200	420		101000
		3681424							
6	12/03/25	ANNUAL SPRINKLER INSPECT - PW	339.00			6020 450000	420		101000
		3695978							
7	08/20/25	ANNUAL FIRE EXT INSPECT - COWF	698.80			1000 455000	420		101000
		3463042							
Total for Vendor:			2,595.80						

* ... Over spent expenditure

Claim/ Line #	Check	Vendor #/Name/ Invoice #/Inv Date/Description	Document \$/ Line \$	Disc \$	PO #	Fund Org Acct	Object	Proj	Cash Account
129371	C	733 SWANSTON EQUIPMENT CORP	595.69						
1	11/26/25	HARDWARE	50.30			1000 430000	381		101000
P19069									
2	11/26/25	RETURN	-6.60			1000 430000	381		101000
P19079									
3	11/26/25	#5402 SHAFT/HARDWARE	655.69			1000 430001	427		101000
P19048									
4	11/26/25	RETURN	-277.88			1000 430000	381		101000
P19077									
5	11/26/25	HARDWARE	94.70			1000 430001	381		101000
P19078									
6	12/01/25	#5402 FILTER	79.48			1000 430001	427		101000
P19114									
129502	C	733 SWANSTON EQUIPMENT CORP	3,929.44						
1	12/09/25	#3035 SHOCK/BUSHING/SEAL	2,769.80			1000 430000	427		101000
P19469									
2	12/09/25	POLY FLAT/CONV WHS	1,159.64			1000 430001	381		101000
P19486									
129540	C	733 SWANSTON EQUIPMENT CORP	2,496.12						
1	12/11/25	CUTTING EDGES	2,496.12			1000 430001	381		101000
P19560									
129554	C	733 SWANSTON EQUIPMENT CORP	166.85						
1	12/11/25	#350B DRIVE/RING	166.85			1000 430000	427		101000
P19559									
		Total for Vendor:	7,188.10						
129443	C	5111 TACMED SOLUTIONS	109.18						
1	12/04/25	cadets, tourniquets	109.18			1000 421000	375		101000
INV179813									
		Total for Vendor:	109.18						

12/12/25
14:56:23

CITY OF WEST FARGO, ND
Claim Details by Posted Date
For Claims from 12/01/25 to 12/12/25

Page: 50 of 67
Report ID: AP100V

* ... Over spent expenditure

Claim/ Line #	Check	Vendor #/Name/ Invoice #/Inv Date/Description	Document \$/ Line \$	Disc \$	PO #	Fund Org Acct	Object	Proj	Cash Account
129593		3829 TARGETSOLUTIONS LEARNING, LLC	6,970.04						
		12/31/2025 thru 12/30/2026							
1	12/01/25	FD 2026 Target Solutions renew	6,970.04			2060 415200	497		101000
131527									
		Total for Vendor:	6,970.04						
129384		1900 THE UPS STORE #5998	18.34						
1	11/13/25	SHIPPING	18.34			6020 450000	360		101000
		Total for Vendor:	18.34						
129591		3411 THE UPS STORE #6740	713.96						
1	12/11/25	FD Ship Smoke Machine/repairs	390.01			2060 415200	661		101000
		244942-1211							
2	12/03/25	FD return hose	12.93			2060 415200	661		101000
		244942-1203							
3	12/11/25	FD ship calibration radon mach	311.02			2060 415200	661		101000
		244942-1211.2							
		Total for Vendor:	713.96						
129346		4557 TIM BROWN SR	194.00						
1	12/04/25	meal reimb	194.00			1000 421000	340		101000
		Total for Vendor:	194.00						
129495	C	3352 TITAN MACHINERY - FARGO	2,339.59						
1	12/04/25	CUTTING EDGES	1,653.54			1000 430001	381		101000
		PS1002704							
3	12/09/25	#4403 FILTER ELEMENT	137.53			6010 450200	427		101000
		PS1037569							
4	12/09/25	#4403 MOTOR ELECTRIC	609.90			6010 450200	427		101000
		PS1037167							
5	12/05/25	CUTTING EDGES	783.66			1000 430001	381		101000
		PS1003596							
6	12/04/25	ACCT CREDIT	-631.74			1000 430001	381		101000
		SR0066426							
7	09/10/25	DUP PAYMENT CREDIT	-213.30			4387 480000	427		101000
		100-9648							
		Total for Vendor:	2,339.59						

12/12/25
14:56:23

CITY OF WEST FARGO, ND
Claim Details by Posted Date
For Claims from 12/01/25 to 12/12/25

Page: 51 of 67
Report ID: AP100V

* ... Over spent expenditure

Claim/ Line #	Check Invoice #/Inv Date/Description	Vendor #/Name/ Invoice #/Inv Date/Description	Document \$/ Line \$	Disc \$	PO #	Fund Org Acct	Object	Proj	Cash Account
129513		1234 TOOL WAREHOUSE INC	612.68						
1	12/05/25	SPIRAL FLUTE/SHANK/PIN	612.68			1000 455000	432		101000
		0284868-IN							
		Total for Vendor:	612.68						
129385	C	1285 TRAFFIC CONTROL CORPORATION	912.00						
1	11/26/25	MOAB RND PED PB	912.00			1000 430002	487		101000
		162081							
129498	C	1285 TRAFFIC CONTROL CORPORATION	6,260.00						
1	12/04/25	EVP EMITTER	6,260.00			1000 430002	487		101000
		162245ADV							
		Total for Vendor:	7,172.00						
129392	C	5653 TRAV'S OUTFITTER	225.99						
1	11/26/25	N PRATT - WINTER BOOTS	225.99			6020 450000	422		101000
		4628							
		Total for Vendor:	225.99						
129320	C	2951 TYLER TECHNOLOGIES, INC	774.10						
1	020-166358	11/30/25 OTC & Portal	774.10			1000 412000	740		101000
		020-166358							
		Total for Vendor:	774.10						
129457		2136 ULINE INC	318.55						
1	11/20/25	SRVCE CART FOR POPCORN MACHINE	318.55			7000 411600	649		101000
		200846266							
		Total for Vendor:	318.55						
129518	C	784 UNITED POWER EQUIPMENT	288.00						
1	12/04/25	#4100 CUSTOM TUBE	288.00			6010 450200	427		101000
		020C8888							
		Total for Vendor:	288.00						

* ... Over spent expenditure

Claim/ Line #	Check	Vendor #/Name/ Invoice #/Inv Date/Description	Document \$/ Line \$	Disc \$	PO #	Fund Org Acct	Object	Proj	Cash Account
129336	C	4067 UNITED TACTICAL SYSTEMS LLC	4,184.20						
1	CC-1884	11/26/25 less lethal semi-auto (4)	4,184.20			1000 421000	987		101000
		0102957-IN							
		Total for Vendor:	4,184.20						
129592		5489 URBAN FOODS CATERING	2,513.20						
1	12/04/25	2025 Awards Ceremoney	2,513.20			2060 415200	378		101000
		4331							
		Total for Vendor:	2,513.20						
129568	C	3668 VERIZON WIRELESS	189.51						
1	11/02/25	nov 2025 - river sensors	189.51			6020 450000	345		101000
		6129890044							
		Total for Vendor:	189.51						
129322		3470 VICKERS LAW	765.00						
1	00834	12/03/25 Alternate Defense Attorney	765.00			1000 412000	310		101000
		00834							
		Total for Vendor:	765.00						
129595	E	3212 VISA ADMINISTRATION	46.27						
1	CC-1901	11/12/25 Midwest Energy Summit - Berni	45.00			1000 202200			101000
		FMWF CHAMBER OF COMMERCE							
2	CC-1901	11/24/25 Mail flash drive	1.27			1000 202200			101000
		USPS							
		Total for Vendor:	46.27						
129327	E	2437 VISA ASSESSING	353.97						
1	CC-1883	11/06/25 Car washes	135.96			1000 202200			101000
		DON'S CAR WASHES, INC							
2	CC-1883	11/19/25 Returned gnat killer	-36.99			1000 202200			101000
		AMAZON CAPITAL SERVICES							
3	CC-1883	11/20/22 2026 annual membership - Paul	255.00			1000 202200			101000
		IAAO							
		Total for Vendor:	353.97						

* ... Over spent expenditure

Claim/ Line #	Check	Vendor #/Name/ Invoice #/Inv Date/Description	Document \$/ Line \$	Disc \$	PO #	Fund Org Acct	Object	Proj	Cash Account
129596	E	3706 VISA COMMUNICATIONS	483.20						
1	CC-1897	11/07/25 Spectrum prime cine lens	483.20			1000 202200			101000
		B&H PHOTO-VIDEO							
		Total for Vendor:	483.20						
				CC Accounting: 1000-		-416200-497			
129597	E	3693 VISA ENGINEERING	2,411.48						
1	CC-1899	11/03/25 Car washes	85.00			1000 202200			101000
		CIRCLE K							
2	CC-1899	11/04/25 Eng clothing - Troy O	236.60			1000 202200			101000
		Duluth Trading Co							
		MISC CLAIM VENDOR							
3	CC-1899	11/05/25 Surveyors Conference - Troy O	283.25			1000 202200			101000
		NDSPLS							
4	CC-1899	11/04/25 Refund for sales tax	-255.56			1000 202200			101000
		Duluth Trading Co							
		MISC CLAIM VENDOR							
5	CC-1899	11/05/25 Refund for sales tax	-15.50			1000 202200			101000
		Scheels							
		MISC CLAIM VENDOR							
6	CC-1899	11/13/25 Staff development - Kyle M	250.00			1000 202200			101000
		UNIVERSITY OF MINNESOTA							
7	CC-1899	11/13/25 Staff development - Oliver N	325.00			1000 202200			101000
		AGC of ND							
		MISC CLAIM VENDOR							
8	CC-1899	11/21/25 ASAP membership - Kayla	199.00			1000 202200			101000
		Diversified Communications - ASAP							
		MISC CLAIM VENDOR							
9	CC-1899	11/20/25 Hotel for conference - Troy O	220.00			1000 202200			101000
		HOLIDAY INN BISMARK							
10	CC-1899	11/20/25 Gas for conference - Troy O	23.10			1000 202200			101000
		SHELL							
11	CC-1899	11/21/25 Dist 2297 - RON Publication	266.00			4192 202200			101000
		COLUMN SOFTWARE PBC							
12	CC-1899	11/21/25 Dist 2296 - RON Publication	259.92			4191 202200			101000
		COLUMN SOFTWARE PBC							
13	CC-1899	11/24/25 Eng boots - Chris L	120.00			1000 202200			101000
		SCHEELS							
				CC Accounting: 1000-		-414200-422			

* ... Over spent expenditure

Claim/ Line #	Check Invoice #	Vendor #/Name/ #/Inv Date/Description	Document \$/ Line \$	Disc \$	PO #	Fund Org Acct	Object	Proj	Cash Account
14	CC-1899	11/24/25 Eng boots - Jerry W	150.00			1000 202200			101000
		RED WING SHOES		CC Accounting:	1000-	-414200-422			
15	CC-1899	11/25/25 Eng shoes - Brandon B	114.70			1000 202200			101000
		LEMS Shoes		CC Accounting:	1000-	-414200-422			
		MISC CLAIM VENDOR							
16	CC-1899	12/01/25 Eng clothing - Brandon B	149.97			1000 202200			101000
		SCHEELS		CC Accounting:	1000-	-414200-422			
		Total for Vendor:	2,411.48						
129426	E	3568 VISA FIRE DEPT 2	1,438.96						
1	CC-1904	10/31/25 Alphabetic File Folders	101.97			2060 202200			101000
		OFFICE DEPOT OFFICEMAX		CC Accounting:	2060-	-415200-410			
2	CC-1904	10/31/25 hanging folders	373.90			2060 202200			101000
		OFFICE DEPOT OFFICEMAX		CC Accounting:	2060-	-415200-410			
3	CC-1904	11/05/25 CRR 500 helmets	385.00			2060 202200			101000
		FIRE SMART PROMOTIONS		CC Accounting:	2060-	-415200-375			
4	CC-1904	11/05/25 Cr Return hanging folders	-297.92			2060 202200			101000
		OFFICE DEPOT OFFICEMAX		CC Accounting:	2060-	-415200-410			
5	CC-1904	11/25/25 Cake Academy Graduation	91.98			2060 202200			101000
		HORNBAACHERS		CC Accounting:	2060-	-415200-375			
6	CC-1904	11/26/25 St 76 Plow-replace broke spri	127.06			2060 202200			101000
		BERT'S TRUCK EQUIPMENT		CC Accounting:	2060-	-415200-420			
7	CC-1904	12/01/25 Battle of Badges blood dr.	656.97			2060 202200			101000
		WALMART BUSINESS		CC Accounting:	2060-	-415200-375			
		Total for Vendor:	1,438.96						
129598	E	4335 VISA HUMAN RESOURCES	3,700.77						
1	CC-1900	11/03/25 Executive membership - Sarah	3,995.00			1000 202200			101000
		SHRM		CC Accounting:	1000-	-414103-340			
2	CC-1900	11/03/25 Refund for membership upgrade	-264.00			1000 202200			101000
		Sarah		CC Accounting:	1000-	-414103-667			
		SHRM							
3	CC-1900	11/04/25 Rush fee for new card	35.00			1000 202200			101000
		FIBT		CC Accounting:	1000-	-414103-410			
		MISC CLAIM VENDOR							
4	CC-1900	11/03/25 Refund for membership upgrade	-73.16			1000 202200			101000
		Sarah		CC Accounting:	1000-	-414103-667			
		SHRM							

* ... Over spent expenditure

Claim/ Line #	Check Invoice #	Vendor #/Name/ Inv Date/Description	Document \$/ Line \$	Disc \$	PO #	Fund Org Acct	Object	Proj	Cash Account
5	CC-1900 11/06/25	Credit for HR Gen job posting LinkedIn MISC CLAIM VENDOR	-268.00			1000 202200 -414103-399			101000
6	CC-1900 11/06/25	Credit for HR Gen job posting LinkedIn MISC CLAIM VENDOR	-273.60			1000 202200 -414103-399			101000
7	CC-1900 11/06/25	Credit for HR Gen job posting LinkedIn MISC CLAIM VENDOR	-283.50			1000 202200 -414103-399			101000
8	CC-1900 11/17/25	ScreenCloud subscriptions - P ScreenCloud MISC CLAIM VENDOR	480.00			1000 202200 -450000-497			101000
9	CC-1900 11/17/25	ScreenCloud subscription- Com ScreenCloud MISC CLAIM VENDOR	240.00			1000 202200 -416200-602			101000
10	CC-1900 12/01/25	ChatGPT subscription - Sarah OpenAI MISC CLAIM VENDOR	30.00			1000 202200 -414103-497			101000
11	CC-1900 12/01/25	ChatGPT subscription - Nick OpenAI MISC CLAIM VENDOR	30.00			1000 202200 -414000-497			101000
12	CC-1900 12/01/25	ChatGPT temp subscriptions- I OpenAI MISC CLAIM VENDOR	53.03			1000 202200 -414104-497			101000
Total for Vendor:			3,700.77						
129599	E	2439 VISA IT	247.42						
1	CC-1902 11/04/25	Alcohol wipes AMAZON CAPITAL SERVICES	27.99			1000 202200 -414104-410			101000
2	CC-1902 11/05/25	Screen wipes/door kick AMAZON CAPITAL SERVICES	70.79			1000 202200 -414104-410			101000
3	CC-1902 11/19/25	Monitor stand/mount - HR AMAZON CAPITAL SERVICES	88.98			1000 202200 -414103-497			101000
4	CC-1902 11/19/25	Webcam - HR AMAZON CAPITAL SERVICES	54.16			1000 202200 -414103-497			101000
5	CC-1902 11/28/25	AC power cable AMAZON CAPITAL SERVICES	5.50			1000 202200 -414104-497			101000
Total for Vendor:			247.42						

* ... Over spent expenditure

Claim/ Line #	Check Invoice #/Inv Date/Description	Vendor #/Name/ #/Inv Date/Description	Document \$/ Line \$	Disc \$	PO #	Fund Org Acct	Object	Proj	Cash Account
129600	E	5092 VISA IT 2	604.27						
1	CC-1903 11/05/25	SSL Certificate Renewal	599.98			1000 202200			101000
		GoDaddy				-414104-497			
		MISC CLAIM VENDOR							
2	CC-1903 11/10/25	Water	4.29			1000 202200			101000
		FAMILY FARE				-414104-410			
		Total for Vendor:	604.27						
129467	E	3161 VISA LIBRARY #1	544.23						
1	CC-1893 11/08/25	SHIPPING TAPE	59.94			7000 202200			101000
		AMAZON CAPITAL SERVICES				-411600-661			
2	CC-1893 11/08/25	CHAIR LEG SOCKS	36.39			7000 202200			101000
		AMAZON CAPITAL SERVICES				-411600-410			
3	CC-1893 11/16/25	PUZZLES	149.90			7000 202200			101000
		AMAZON CAPITAL SERVICES				-411600-649			
4	CC-1893 11/26/25	PUREWATER	298.00			7000 202200			101000
		LEASE FOR WATER MACHINES				-411600-410			
		MISC CLAIM VENDOR							
		Total for Vendor:	544.23						
129469	E	3162 VISA LIBRARY #2	498.59						
1	CC-1894 11/14/25	PROGRAM SUPPLIES	73.90			7000 202200			101000
		WALMART				-411600-649			
2	CC-1894 11/20/25	TAX REFUND	-11.44			7000 202200			101000
		CANAD INN DESTINATION CENTER GRAND FORKS				-411600-340			
3	CC-1894 11/20/25	TAX REFUND	-11.44			7000 202200			101000
		CANAD INN DESTINATION CENTER GRAND FORKS				-411600-340			
4	CC-1894 11/20/25	TAX REFUND	-11.44			7000 202200			101000
		CANAD INN DESTINATION CENTER GRAND FORKS				-411600-340			
5	CC-1894 11/20/25	TAX REFUND	-11.44			7000 202200			101000
		CANAD INN DESTINATION CENTER GRAND FORKS				-411600-340			
6	CC-1894 11/20/25	TAX REFUND	-22.88			7000 202200			101000
		CANAD INN DESTINATION CENTER GRAND FORKS				-411600-340			
7	CC-1894 11/20/25	TAX REFUND	-11.44			7000 202200			101000
		CANAD INN DESTINATION CENTER GRAND FORKS				-411600-340			
8	CC-1894 11/20/25	TAX REFUND	-11.44			7000 202200			101000
		CANAD INN DESTINATION CENTER GRAND FORKS				-411600-340			

* ... Over spent expenditure

Claim/ Line #	Check Invoice #	Vendor #/Name/ #/Inv Date/Description	Document \$/ Line \$	Disc \$	PO #	Fund Org Acct	Object	Proj	Cash Account
9	CC-1894	11/28/25 FORUM SUBSCRIPTION	356.29			7000 202200			101000
		11/27/25-11/27/26							
		FORUM COMMUNICATIONS		CC Accounting:	7000-	-411600-663			
10	CC-1894	11/28/25 CLEAR BAGS	159.92			7000 202200			101000
		AMAZON CAPITAL SERVICES		CC Accounting:	7000-	-411600-662			
Total for Vendor:			498.59						
129494	E	4576 VISA LIBRARY #3	1,372.68						
1	CC-1895	10/21/25 PROGRAM SUPPLIES	16.97			7000 202200			101000
		FAMILY FARE		CC Accounting:	7000-	-411600-649			
2	CC-1895	10/29/25 HALLOWEEN CANDY	44.78			7000 202200			101000
		COSTCO WHOLESALE #1119		CC Accounting:	7000-	-411600-410			
3	CC-1895	10/29/25 RETURN 5 CARTS	-558.38			7000 202200			101000
		COSTCO WHOLESALE #1119		CC Accounting:	7000-	-411600-653			
4	CC-1895	10/31/25 FACEBOOK	52.94			7000 202200			101000
		MEDIA ADVERTISING		CC Accounting:	7000-	-411600-689			
		MISC CLAIM VENDOR							
5	CC-1895	11/04/25 COVER ONE, INC	66.90			7000 202200			101000
		ADHESIVE GLUE STRIPS		CC Accounting:	7000-	-411600-410			
		MISC CLAIM VENDOR							
6	CC-1895	11/07/25 TAX REFUND	-57.89			7000 202200			101000
		COSTCO WHOLESALE #1119		CC Accounting:	7000-	-411600-653			
7	CC-1895	11/21/25 MAILERLITE	1,177.20			7000 202200			101000
		RENEW ANNUAL SUBSCRIPTION 11/21/25 -11/21/26		CC Accounting:	7000-	-411600-689			
		MISC CLAIM VENDOR							
8	CC-1895	11/21/25 STEAM CLEANER	170.99			7000 202200			101000
		AMAZON CAPITAL SERVICES		CC Accounting:	7000-	-411600-641			
9	CC-1895	11/26/25 PROGRAM SUPPLIES	285.37			7000 202200			101000
		AMAZON CAPITAL SERVICES		CC Accounting:	7000-	-411600-649			
10	CC-1895	11/30/25 FACEBOOK	173.80			7000 202200			101000
		MEDIA ADVERTISING		CC Accounting:	7000-	-411600-689			
		MISC CLAIM VENDOR							
Total for Vendor:			1,372.68						

* ... Over spent expenditure

Claim/ Line #	Check Invoice #	Vendor #/Name/ #/Inv Date/Description	Document \$/ Line \$	Disc \$	PO #	Fund Org Acct	Object	Proj	Cash Account
129601	E	2438 VISA PLANNING	540.87						
1	CC-1898	11/03/25 License renewal - Mike Carlso	110.00			1000 202200			101000
		INTERNATIONAL CODE COUNCIL, INC							
2	CC-1898	11/14/25 Membership - Steve Iverson	224.95			1000 202200			101000
		Planetizen							
		MISC CLAIM VENDOR							
3	CC-1898	11/17/25 Book	160.32			1000 202200			101000
		Inspections							
		AMAZON CAPITAL SERVICES							
4	CC-1898	11/20/25 PZ 12.09 Meyer's 2nd Add Rezo	45.60			1000 202200			101000
		COLUMN SOFTWARE PBC							
		Total for Vendor:	540.87						
129330	E	2435 VISA POLICE #1	1,273.33						
1	CC-1889	11/06/25 wellness conf, fuel stanton/or	46.25			1000 202200			101000
		MISC CLAIM VENDOR							
2	CC-1889	11/07/25 wellness conf, lodging stanton	127.24			1000 202200			101000
		MISC CLAIM VENDOR							
3	CC-1889	11/07/25 wellness conf, lodging orn	127.24			1000 202200			101000
		MISC CLAIM VENDOR							
4	CC-1889	11/25/25 KEH camera body	488.16			1000 202200			101000
		MISC CLAIM VENDOR							
5	CC-1889	11/25/25 KOLARI, camera lens	484.44			1000 202200			101000
		MISC CLAIM VENDOR							
		Total for Vendor:	1,273.33						
129331	E	3233 VISA POLICE #2	3,726.08						
1	CC-1888	11/07/25 breakroom coffee machine	1,003.65			1000 202200			101000
		MISC CLAIM VENDOR							
2	CC-1888	11/13/25 challenge coins - training	1,191.25			1000 202200			101000
		CUSTOM CHALLENGE COINS							
3	CC-1888	11/14/25 kitchen supplies	44.34			1000 202200			101000
		SAM'S CLUB MC/SYNCB							
4	CC-1888	11/14/25 coffee & cleaning supplies	393.78			1000 202200			101000
		COSTCO WHOLESALE #1119							
5	CC-1888	11/14/25 kitchen supplies	398.64			1000 202200			101000
		COSTCO WHOLESALE #1119							

* ... Over spent expenditure

Claim/ Line #	Check Invoice #	Vendor #/Name/ #/Inv Date/Description	Document \$/ Line \$	Disc \$	PO #	Fund Org Acct	Object	Proj	Cash Account
6	CC-1888 11/20/25	K9 harness for thor	323.32			1000 202200			101000
		MODERN ICON K9 GEAR		CC Accounting:	1000-	-421000-915			
7	CC-1888 11/22/25	K9 pet insurance	371.10			1000 202200			101000
		MISC CLAIM VENDOR		CC Accounting:	1000-	-421000-915			
Total for Vendor:			3,726.08						
129332	E 3234	VISA POLICE #3	738.93						
1	CC-1887 11/12/25	PRI reg for melting	195.00			1000 202200			101000
		PRI MANAGEMENT GROUP		CC Accounting:	1000-	-421000-340			
2	CC-1887 11/13/25	swearing in bakery	149.79			1000 202200			101000
		HORNBACHERS		CC Accounting:	1000-	-421000-375			
3	CC-1887 11/14/25	refund - clover's training	-80.00			1000 202200			101000
		MISC CLAIM VENDOR		CC Accounting:	1000-	-421000-915			
4	CC-1887 11/18/25	FTO training, casperson	330.39			1000 202200			101000
		EXPEDIA.COM HEADQUARTERS		CC Accounting:	1000-	-421000-340			
5	CC-1887 11/25/25	grooming labby	143.75			1000 202200			101000
		SIT. STAY. SPA.		CC Accounting:	1000-	-421000-915			
Total for Vendor:			738.93						
129333	E 3244	VISA POLICE #4	283.55						
1	CC-1886 11/20/25	holiday stamps	283.55			1000 202200			101000
		USPS		CC Accounting:	1000-	-421000-661			
Total for Vendor:			283.55						
129334	E 4300	VISA POLICE #5	698.85						
1	CC-1885 12/01/25	battle of the badges items	598.85			1000 202200			101000
		WALMART		CC Accounting:	1000-	-421000-375			
2	CC-1885 12/01/25	battle of the badges items	100.00			1000 202200			101000
		WEST FARGO DQ GRILL & CHILL		CC Accounting:	1000-	-421000-375			
Total for Vendor:			698.85						
129335	E 4301	VISA POLICE #6	269.37						
1	CC-1884 11/02/25	LETA fuel, K. Kelly	31.68			1000 202200			101000
		MISC CLAIM VENDOR		CC Accounting:	1000-	-421000-340			
2	CC-1884 11/07/25	LETA fuel, K. Kelly	38.71			1000 202200			101000
		EXXON EXPRESS - WASHINGTON		CC Accounting:	1000-	-421000-340			
3	CC-1884 11/09/25	LETA fuel, K. Kelly	31.37			1000 202200			101000
		RED CARPET EXXON EXPRESS		CC Accounting:	1000-	-421000-340			

* ... Over spent expenditure

Claim/ Line #	Check Invoice #	Vendor #/Name/ Inv Date/Description	Document \$/ Line \$	Disc \$	PO #	Fund Org Acct	Object	Proj	Cash Account
4	CC-1884 11/14/25	LETA fuel, K. Kelly	41.87			1000 202200			101000
		MISC CLAIM VENDOR		CC Accounting: 1000-		-421000-340			
5	CC-1884 11/16/25	LETA fuel, K. Kelly	28.81			1000 202200			101000
		RED CARPET EXXON EXPRESS		CC Accounting: 1000-		-421000-340			
6	CC-1884 11/19/25	LETA fuel, K. Kelly	42.61			1000 202200			101000
		MISC CLAIM VENDOR		CC Accounting: 1000-		-421000-340			
7	CC-1884 11/27/25	LETA fuel, K. Kelly	24.12			1000 202200			101000
		MISC CLAIM VENDOR		CC Accounting: 1000-		-421000-340			
8	CC-1884 11/30/25	LETA fuel, K. Kelly	30.20			1000 202200			101000
		RED CARPET EXXON EXPRESS		CC Accounting: 1000-		-421000-340			
Total for Vendor:			269.37						
128839	-95378E 2423	VISA PUBLIC WORKS #1	4,161.76						
1	CC-1866 10/02/25	CH - BIKE RACK	464.57			2970 202200			101000
		BARCO PRODUCTS		CC Accounting: 2970-		-480000-653			
		MISC CLAIM VENDOR							
2	CC-1866 10/08/25	R HELMING PANTS	249.95			2210 202200			101000
		RUNNINGS		CC Accounting: 2210-		-428000-340			
3	CC-1866 10/07/25	VEH TITLE	25.00			1000 202200			101000
		DMV FARGO BRANCH		CC Accounting: 1000-		-430002-870			
4	CC-1866 10/09/25	D JOHN - LICENSE	200.00			1000 202200			101000
		NDSU EXTENSION PESTICIDE PROGRAM		CC Accounting: 1000-		-450000-340			
5	CC-1866 10/09/25	S HANSON - LICENSE	200.00			1000 202200			101000
		NDSU EXTENSION PESTICIDE PROGRAM		CC Accounting: 1000-		-430001-340			
6	CC-1866 10/09/25	A HAGLE - LICENSE	200.00			1000 202200			101000
		NDSU EXTENSION PESTICIDE PROGRAM		CC Accounting: 1000-		-430001-340			
7	CC-1866 10/09/25	D JOHN -MULTI CLASS DISCOUNT	-75.00			1000 202200			101000
		NDSU EXTENSION PESTICIDE PROGRAM		CC Accounting: 1000-		-450000-340			
8	CC-1866 10/09/25	S&A - MULTI CLASS DISCOUNT	-150.00			1000 202200			101000
		NDSU EXTENSION PESTICIDE PROGRAM		CC Accounting: 1000-		-430001-340			
9	CC-1866 10/14/25	L PORTER - PANTS	154.97			1000 202200			101000
		FLEET FARM		CC Accounting: 1000-		-455000-422			
10	CC-1866 10/14/25	J BENEDICT ARBORITS CERTIFICA	220.00			2210 202200			101000
		INTERNATIONAL SOCIETY OF ARBICULTURE		CC Accounting: 2210-		-428000-340			
		MISC CLAIM VENDOR							
11	CC-1866 10/15/25	SA - WINTER GLOVES	820.68			6010 202200			101000
		FULL SOURCE LLC		CC Accounting: 6010-		-450200-639			

* ... Over spent expenditure

Claim/ Line #	Check Invoice #	Vendor #/Name/ Inv Date/Description	Document \$/ Line \$	Disc \$	PO #	Fund Org Acct	Object	Proj	Cash Account
12	CC-1866	10/15/25 WA - WINTER GLOVES	166.07			6020 202200			101000
	FULL SOURCE LLC			CC Accounting:	6020-	-450000-639			
13	CC-1866	10/15/25 SW - WINTER GLOVES	166.07			6025 202200			101000
	FULL SOURCE LLC			CC Accounting:	6025-	-450000-639			
14	CC-1866	10/15/25 ST - WINTER GLOVES	166.07			1000 202200			101000
	FULL SOURCE LLC			CC Accounting:	1000-	-430000-639			
15	CC-1866	10/16/25 SA - GLOVE REFUND	-492.70			6010 202200			101000
	FULL SOURCE LLC			CC Accounting:	6010-	-450200-639			
16	CC-1866	10/16/25 WA - GLOVE REFUND	-82.12			6020 202200			101000
	FULL SOURCE LLC			CC Accounting:	6020-	-450000-639			
17	CC-1866	10/16/25 SW - GLOVE REFUND	-82.12			6025 202200			101000
	FULL SOURCE LLC			CC Accounting:	6025-	-450000-639			
18	CC-1866	10/16/25 ST - GLOVE REFUND	-82.11			1000 202200			101000
	FULL SOURCE LLC			CC Accounting:	1000-	-430000-639			
19	CC-1866	10/20/25 S GRAVALIN BOOTS	189.99			1000 202200			101000
	BRUNT WORKWEAR			CC Accounting:	1000-	-430000-422			
20	CC-1866	10/21/25 JUMP STARTER	199.95			6010 202200			101000
	FLEET FARM			CC Accounting:	6010-	-450200-433			
21	CC-1866	10/20/25 R HELMING TRAINING	224.25			2210 202200			101000
	TREE CARE INDUSTRY ASSOCIATION			CC Accounting:	2210-	-428000-340			
22	CC-1866	10/23/25 A SPORES - COVERALLS	209.99			1000 202200			101000
	RUNNINGS			CC Accounting:	1000-	-430000-422			
23	CC-1866	10/20/25 K600 OZONE MONITOR	1,268.25			6025 202200			101000
	OXIDATION TECHNOLOGIES LLC			CC Accounting:	6025-	-450000-639			
129450	E	2423 VISA PUBLIC WORKS #1	4,536.82						
1	CC-1890	11/03/25 FORESTRY TOOLS	1,025.86			2210 202200			101000
	SHERRILLTREE DBA VERTICAL SUPPLY GROUP			CC Accounting:	2210-	-428000-432			
2	CC-1890	11/07/25 R BELL - COAT	46.98			1000 202200			101000
	BUFFALO OUTDOORS			CC Accounting:	1000-	-430000-422			
	MISC CLAIM VENDOR								
3	CC-1890	11/10/25 J STECKLER-JOHNSON - BIBS	209.99			6020 202200			101000
	FLEET FARM			CC Accounting:	6020-	-450000-422			
4	CC-1890	11/13/25 S MELBARZDIS - MUCKBOOTS	151.18			1000 202200			101000
	GRAINGER, INC.			CC Accounting:	1000-	-430000-422			
5	CC-1890	11/13/25 S WANOUS - BIBS	129.99			1000 202200			101000
	FLEET FARM			CC Accounting:	1000-	-430000-422			

* ... Over spent expenditure

Claim/ Line #	Check Invoice	Vendor #/Name/ #/Inv Date/Description	Document \$/ Line \$	Disc \$	PO #	Fund Org Acct	Object	Proj	Cash Account
6	CC-1890 11/14/25	R JENSEN - GLOVES	17.98			2210 202200			101000
	FLEET FARM			CC Accounting:	2210-	-428000-422			
7	CC-1890 11/17/25	Z BELLMORE - MUCKBOOTS	145.00			6025 202200			101000
	FLEET FARM			CC Accounting:	6025-	-450000-422			
8	CC-1890 11/19/25	WOOD DOLLY	51.96			1000 202200			101000
	HARBOR FREIGHT TOOLS			CC Accounting:	1000-	-430000-358			
9	CC-1890 11/20/25	PRYBARS/DUAL LED	139.95			1000 202200			101000
	HARBOR FREIGHT TOOLS			CC Accounting:	1000-	-455000-432			
10	CC-1890 11/19/25	VEHICLE TITLE	25.00			6020 202200			101000
	DMV FARGO BRANCH			CC Accounting:	6020-	-450000-870			
11	CC-1890 11/21/25	P GBAGBE - PANTS	89.98			6010 202200			101000
	FLEET FARM			CC Accounting:	6010-	-450200-422			
12	CC-1890 11/24/25	S MELBARZDIS - BIBS	129.99			1000 202200			101000
	FLEET FARM			CC Accounting:	1000-	-430000-422			
13	CC-1890 11/25/25	R HELMING - DUES	35.00			2210 202200			101000
	ISA (PURCHASE) 678-367-0981			CC Accounting:	2210-	-428000-667			
14	CC-1890 11/25/25	R JENSEN - DUES/MEMBERSHIP	170.00			2210 202200			101000
	ISA (PURCHASE) 678-367-0981			CC Accounting:	2210-	-428000-667			
15	CC-1890 11/25/25	R LUGER - DUES	35.00			2210 202200			101000
	ISA (PURCHASE) 678-367-0981			CC Accounting:	2210-	-428000-667			
16	CC-1890 11/25/25	J BENEDICT - DUES/MEMBERSHIP	170.00			2210 202200			101000
	ISA (PURCHASE) 678-367-0981			CC Accounting:	2210-	-428000-667			
17	CC-1890 11/25/25	J BENEDICT - CONF REG	300.00			2210 202200			101000
	DAKOTAS CHAPTER - ISA			CC Accounting:	2210-	-428000-340			
18	CC-1890 11/25/25	R HELMING - CONF REG	300.00			2210 202200			101000
	DAKOTAS CHAPTER - ISA			CC Accounting:	2210-	-428000-340			
19	CC-1890 11/25/25	R JENSEN - CONF REG	300.00			2210 202200			101000
	DAKOTAS CHAPTER - ISA			CC Accounting:	2210-	-428000-340			
20	CC-1890 11/26/25	R JENSEN - ARBORIST CERT FE	40.00			2210 202200			101000
	ISA (PURCHASE) 678-367-0981			CC Accounting:	2210-	-428000-340			
21	CC-1890 12/01/25	R LUGER - BIBS	149.99			2210 202200			101000
	FLEET FARM			CC Accounting:	2210-	-428000-422			
22	CC-1890 12/01/25	R JENSEN - BIBS/GLOVES	237.97			2210 202200			101000
	RUNNINGS			CC Accounting:	2210-	-428000-422			
23	CC-1890 12/01/25	C ZANDER/D SCHACHER CONF REG	600.00			2210 202200			101000
	DAKOTAS CHAPTER - ISA			CC Accounting:	2210-	-428000-340			
24	CC-1890 12/01/25	C ZANDER DUES	35.00			2210 202200			101000
	ISA (PURCHASE) 678-367-0981			CC Accounting:	2210-	-428000-667			
Total for Vendor:			8,698.58						

* ... Over spent expenditure

Claim/ Line #	Check Invoice #	Vendor #/Name/ Inv Date/Description	Document \$/ Line \$	Disc \$	PO #	Fund Org Acct	Object	Proj	Cash Account
129451	E	4256 VISA PUBLIC WORKS #2	711.57						
1	CC-1891	11/18/25 SAWHORSES	59.96			6025 202200			101000
		LOWE'S		CC Accounting: 6025-		-450000-825			
2	CC-1891	11/17/25 C JOCHIM/J DOCKTER TRAINING	490.00			1000 202200			101000
		MN STATE COLLEGES		CC Accounting: 1000-		-455000-340			
		MISC CLAIM VENDOR							
3	CC-1891	11/21/25 J NOVACEK - BIBS	161.61			6020 202200			101000
		FLEET FARM		CC Accounting: 6020-		-450000-422			
		Total for Vendor:	711.57						
129452	E	4625 VISA PUBLIC WORKS #3	6,573.55						
1	CC-1892	11/06/25 B MATZKE LODGING	1,603.55			1000 202200			101000
		SHERATON SAN DIEGO		CC Accounting: 1000-		-450000-340			
		MISC CLAIM VENDOR							
2	CC-1892	11/06/25 C COSTELLO LODGING	1,603.55			6020 202200			101000
		SHERATON SAN DIEGO		CC Accounting: 6020-		-450000-340			
		MISC CLAIM VENDOR							
3	CC-1892	11/06/25 B HANSON LODGING	1,603.55			6020 202200			101000
		SHERATON SAN DIEGO		CC Accounting: 6020-		-450000-340			
		MISC CLAIM VENDOR							
4	CC-1892	11/20/25 FORESTRY CONF LODGING	1,762.90			2210 202200			101000
		BISMARCK HOTEL & CONFERENCE CENTER		CC Accounting: 2210-		-428000-340			
		Total for Vendor:	6,573.55						
129370	C	544 WALLWORK TRUCK CENTER	110.68						
1		11/26/25 #4200 MUDFLAP	34.92			6010 450200	427		101000
		01P662041							
2		12/01/25 #7045 VALVE	75.76			4387 480000	427		101000
		01P662823							
129479	C	544 WALLWORK TRUCK CENTER	606.38						
1		11/21/25 #7045 ECM PARAMETERS	270.00			4387 480000	427		101000
		0109S157229							
2		12/05/25 #4100 HEATER KIT	86.22			6010 450200	427		101000
		01P664214							
3		12/05/25 #7001 OIL COALESCING CARTRIDGE	120.84			6025 450000	427		101000
		01P664573							

12/12/25
14:56:24

CITY OF WEST FARGO, ND
Claim Details by Posted Date
For Claims from 12/01/25 to 12/12/25

Page: 64 of 67
Report ID: AP100V

* ... Over spent expenditure

Claim/ Line #	Check Invoice #/Inv Date/Description	Vendor #/Name/ Invoice #/Inv Date/Description	Document \$/ Line \$	Disc \$	PO #	Fund Org Acct	Object	Proj	Cash Account
4	12/09/25 #3100	FITTING/HOSE ASSY	37.57			1000 430000	427		101000
	01P665731								
5	12/10/25 #407	GOVERNOR	91.75			6010 450200	427		101000
	01P666228								
129556	C	544 WALLWORK TRUCK CENTER	24.87						
1	12/05/25 #7048	PLUG	24.87			4387 480000	427		101000
	01P663041								
		Total for Vendor:	741.93						
129462	C	4773 WEST FARGO EVENTS	40,428.85						
1	1594 12/01/25	Essentia Health Plaza Fee	18,205.42			2310 452120	810		101000
	1594								
2	1594 12/01/25	POW/MIA Plaza Fee	5,574.70			2310 452120	810		101000
	1594								
3	1594 12/01/25	Parking Ramp Management Fee	11,840.33			2320 452110	810		101000
	1594								
4	1594 12/01/25	City Events Management	4,808.40			2960 411900	810		101000
	1594								
		Total for Vendor:	40,428.85						
129410	C	2184 WEST SIDE STEEL	217.70						
1	12/03/25	DUMPSTER REPAIR	217.70			6010 450200	914		101000
	13938								
		Total for Vendor:	217.70						
129429	-95270E	3549 WEX FSA	3,554.95						
1	12/12/25	Med FSA - 12/12/25 payroll	388.33			1000 212530			101000
2	12/12/25	Dep FSA - 12/12/25 payroll	3,166.62			1000 212523			101000
		Total for Vendor:	3,554.95						
129493	C	807 WEX HEALTH, INC	841.25						
1	0002267677 11/30/25	COBRA/FSA/HSA - Nov	841.25			1000 414103	307		101000
	0002267677-IN								

12/12/25
14:56:24

CITY OF WEST FARGO, ND
Claim Details by Posted Date
For Claims from 12/01/25 to 12/12/25

Page: 65 of 67
Report ID: AP100V

* ... Over spent expenditure

Claim/ Line #	Check	Vendor #/Name/ Invoice #/Inv Date/Description	Document \$/ Line \$	Disc \$	PO #	Fund Org Acct	Object	Proj	Cash Account
129536	C	807 WEX HEALTH, INC	2,257.67						
1	0000037553	12/11/25 COBRA Premium Adj	2,257.67			1000 414103	307		101000
		0000037553							
		Total for Vendor:	3,098.92						
129303	-95379E	4676 WEX HSA	40,268.13						
		11.28.25 Payroll							
1	11/28/25	HSA Contributions - ER	12,066.41			1000 212530			101000
2	11/28/25	HSA Contributions - EE	28,201.72			1000 212530			101000
129566	-95261E	4676 WEX HSA	39,515.62						
		12.12.25 Payroll							
1	12/12/25	HSA Contributions - ER	12,050.78			1000 212530			101000
2	12/12/25	HSA Contributions - EE	27,464.84			1000 212530			101000
		Total for Vendor:	79,783.75						
129441		569 WF ANIMAL HOSPITAL	2,904.59						
1	12/01/25	nov 2025 pound fees	2,655.00			1000 421000	396		101000
		307048							
2	11/30/25	jazz & labby medical	249.59			1000 421000	915		101000
		306456							
		Total for Vendor:	2,904.59						
129455		565 WF FIRE FIGHTERS RELIEF	237,152.05						
		2025 1/2 relief funds from ND Insurance Dept.							
1	12/02/25	2025 relief funds from ND Ins	237,152.05			2060 415200	797		101000
		2025 ND Ins Payment							
		Total for Vendor:	237,152.05						
129458	C	549 WF PUB SCHOOLS DIST #6	10,643.55						
1	12/01/25	DECEMBER RENT	10,643.55			7000 411600	333		101000
		260137							
		Total for Vendor:	10,643.55						

12/12/25
14:56:24

CITY OF WEST FARGO, ND
Claim Details by Posted Date
For Claims from 12/01/25 to 12/12/25

Page: 66 of 67
Report ID: AP100V

* ... Over spent expenditure

Claim/ Line #	Check Invoice #/Inv Date/Description	Vendor #/Name/ Invoice #/Inv Date/Description	Document \$/ Line \$	Disc \$	PO #	Fund Org Acct	Object	Proj	Cash Account
129519		2740 WM CORPORATE SERVICES, INC	101,343.52						
1	12/01/25	WATERTOWER DROPSITE	7,862.01			6010 450200	916		101000
6810922									
2	12/01/25	SANITATION DROPSITE	1,310.25			6010 450200	916		101000
6810923									
3	12/01/25	COWF MASTER BILLING	92,171.26			6010 450200	916		101000
6810924									
129594		2740 WM CORPORATE SERVICES, INC	23.96						
1	12/03/25	FD December Services	23.96			2060 415200	527		101000
29	93565 43003								
		Total for Vendor:	101,367.48						
129418	E	338 XCEL ENERGY	24,747.25						
1	12/02/25	3050 SHEYENNE - THE LIGHTS	277.19			2310 452120	527		101000
955285244									
2	12/02/25	3150 SHEYENNE - THE LIGHTS	113.22			2310 452120	527		101000
955259653									
3	12/02/25	735 7TH AVE NW	137.40			1000 430002	527		101000
955286252									
4	12/03/25	PD - 800 4TH AVE E	8,518.08			1000 415000	527		101000
955371621									
5	12/03/25	PD - 800 4TH AVE E	727.32			1000 415000	527		101000
955417162									
6	12/03/25	LIFT STATIONS	14,974.04			6020 450000	527		101000
955365904									
129419	E	338 XCEL ENERGY	12,164.95						
1	11/24/25	901 10TH AVE E	47.76			1000 430002	527		101000
954437599									
2	11/24/25	1100 12TH AVE NW	255.97			6020 450000	527		101000
954438499									
3	11/24/25	309 2ND AVE W	22.01			1000 430002	527		101000
954421406									
4	11/24/25	312 5TH AVE W	323.72			1000 430002	527		101000
954405228									

* ... Over spent expenditure

Claim/ Line #	Check Invoice #/Inv Date/Description	Vendor #/Name/ #/Inv Date/Description	Document \$/ Line \$	Disc \$	PO #	Fund Org Acct	Object	Proj	Cash Account
5	12/01/25 PD - 800 4TH AVE E		8,948.28			1000 415000	527		101000
955015585									
6	11/25/25 STREET LIGHT FEED POINTS		1,572.63			1000 430002	527		101000
954600085									
7	11/25/25 PW STORAGE BUILDING		712.55			6020 450000	527		101000
954600085									
8	11/25/25 1690 13TH AVE S		49.43			1000 430002	527		101000
954616768									
9	11/25/25 1410 13TH AVE E		46.08			1000 430002	527		101000
954639102									
10	11/25/25 1680 13TH AVE E		126.44			1000 430002	527		101000
954623538									
11	11/24/25 60L		60.08			6020 450000	527		101000
954401492									
		Total for Vendor:	36,912.20						
129414	C 582 ZEP SALES AND SERVICE		852.04						
1	11/26/25 CLEANING SUPPLIES		759.43			6020 450000	500		101000
9012111773									
2	12/02/25 CLEANING SUPPLIES		92.61			6020 450000	500		101000
9012125741									
129496	C 582 ZEP SALES AND SERVICE		2,784.88						
1	12/02/25 CLEANING SUPPLIES		2,784.88			6020 450000	500		101000
9012125740									
		Total for Vendor:	3,636.92						
		# of Claims	295	Total:	3604,176.35	# of Vendors	72		
		Total Electronic Claims	2330,757.73						
		Total Non-Electronic Claims	1273418.62						

** This report runs by Claim Posted Date, which is a system generated field that always shows the date on which the Claim was actually posted in the system. If a Claim was cancelled and re-posted, the posted date will show as of the date it was re-posted. **



"Consent" or "Regular" Agenda Item?
[Consent]

To: West Fargo City Commission
From: Dustin Scott, City Administrator
Date: December 15, 2025

Subject: Improvement District No. 2290 – 2025 Public Works Mill & Overlay
Action: Cost Analysis Update – Informational Only / No Action Required

Commission President

Bernie Dardis
Primary Portfolio:
Administrative Services
Secondary Portfolio:
Police & Fire

Commission Vice President

Brad Olson
Primary Portfolio:
Police & Fire
Secondary Portfolio:
Street, Water & Sewer

Commissioner

Roben Anderson
Primary Portfolio:
Community & Development Services
Secondary Portfolio:
Administrative Services

Commissioner

Rory Jorgensen
Primary Portfolio:
Sanitation
Secondary Portfolio:
Community & Development Services

Commissioner

Amy Zundel
Primary Portfolio:
Street, Water & Sewer
Secondary Portfolio:
Sanitation

City Administrator

Dustin T. Scott

New Information and Recommendation:

In October of this year, the Engineering and Public Works Departments worked together to produce the attached memorandum that details final costs tabulated for the construction of Improvement District No. 2290 – 2025 Public Works Mill & Overlay.

The memorandum does a good job of covering the methodology used to calculate the costs of the project. Please refer to that document for details.

The following documents are attached for review/consideration:

- Cost Analysis of Improvement District #2290 Memorandum

Staff Recommendation: Cost Analyst Update - Informational only / No action required

Previously Presented Information and Commission Actions:

June 2, 2025 –

- **Staff Recommendation:** Approve Contract and Contractor's Bond and Authorize Notice to Proceed.
- **Commission Action:** Commissioner Olson moved, and Commissioner Jorgensen seconded to approve. No opposition, motion carried.

May 19, 2025 –

- **Staff Recommendation:** Accept Bid and Award contract to Border States Paving, Inc. for their bid amount of \$708,050.39
- **Commission Action:** Commissioner Anderson moved, and Commissioner Zundel seconded to approve. No opposition, motion carried.

May 15, 2025 – Virtual Bid Opening was held at 10:30 AM

April 21, 2025 –

- **Staff Recommendation:** Reject all bids and Authorize Re-Advertisement for bids to rebid the project
- **Commission Action:** Commissioner Jorgensen moved, and Commissioner Zundel seconded to approve. No opposition, motion carried.

April 10, 2025 – Virtual Bid Opening was held at 10:30 AM

March 17, 2025 –

- **Staff Recommendation:** Approve Plans and Specifications and Direct Advertisement for Bids.
- **Commission Action:** Commissioner Olson moved, and Commissioner Anderson seconded to approve. No opposition, motion carried.

February 3, 2025

- **Staff Recommendation:** Conduct the Determination of Protest Sufficiency and Approve associated Resolution
- **Commission Action:** Commissioner Jorgensen moved, and Commissioner Zundel seconded to approve. No opposition, motion carried.

December 16, 2024

- **Staff Recommendation:** Approve Amended Resolution Creating Improvement District No. 2290, Approve Engineer's Report, Authorize Resolution of Necessity; and Direct Engineer to prepare Plans and Specifications
- **Commission Action:** Commissioner Jorgensen moved, and Commissioner Zundel seconded to approve. No opposition, motion carried.

December 2, 2024

- **Staff Recommendation:** Create Improvement District No. 2290, and Direct Engineer to prepare an Engineer's Report.
- **Commission Action:** Commissioner Zundel moved, and Commissioner Olson seconded to approve. No opposition, motion carried

To: West Fargo City Commission

From: Dan Hanson, Senior Director of Community & Development Services

Date: October 23, 2025

Subject: Cost Analysis of Improvement District #2290 – 2025 Public Works Mill & Overlay – Westwynd, Tintes Holding Co., South Park, and Lenzmeier’s Subdivisions

The purpose of this Memorandum is to report the final costs tabulated for the construction of Improvement District No. 2290 – 2025 Public Works Mill & Overlay. This memo does not compare the costs of this project to those of a consultant-designed and publicly bid project; its sole purpose is to present the final costs and preliminary assessments to the neighborhoods within Improvement District 2290.

For reference, in 2023, staff presented a proposed mill & overlay project that would have been constructed in several neighborhoods. The estimated assessment of that project, at that time proposed to be assessed at 80%, was estimated to be \$4,000 per single family residential house. On January 8, 2024, a hearing of protest was held by the Commission and ultimately the Commission voted not to proceed with that project. Arguments from residents on the amount of the special assessments appeared to have a significant impact on that decision. The message to the staff from that meeting was to find a way to complete these type of projects with smaller special assessments to the benefiting properties.

Thus, City staff proceeded with Improvement District 2290 which was constructed this year. The project involved city staff designing it to have contractors complete concrete curb work, milling of the roadways, and supplying asphalt and tack oil - all which were publicly bid. The City’s Public Works staff installed the wearing course. The proposed special assessments for this project include 50% of all publicly bid project work, and encompass soft costs such as engineering, materials testing, legal & administration, and bonding costs. Not intended to be assessed are any of the City’s labor and equipment costs used to construct the project.

2515 6th Street E
West Fargo, ND 58078
701-515-5100
engineering@westfargond.gov
westfargond.gov

During the planning of the 2023 project and the current Improvement District 2290, concrete pedestrian ramps compliant with modern standards were proposed for installation and funding through the Capital Improvements Sales Tax (CIST), utilizing the line item noted in the 2024 Capital Improvements Plan (CIP) that identifies annual pedestrian ramp replacements. The city bid the curb ramp replacements within the Improvement District 2290 area separately under Project No. 2291, and these are not included in the proposed assessments. The reason for this was again to lower the assessments to the benefiting properties.

Included with this memo are four attachments. They are described as follows:

1. Attachment A, is the analysis completed by Public Works Department detailing their labor and equipment costs.
2. Attachment B, which combines the Public Works Department's costs with the Improvement District 2290 bid costs provided by Border States Paving, the low bidder, along with soft costs.
3. Attachment C is an excerpt from the original Engineer's Report, approved by the Commission at the December 16th, 2024, meeting, that detailed the anticipated costs of the project to provide a comparison between what was proposed and approved vs. the final costs of the project.
4. Attachment D is a map showing preliminary assessment costs based on the final expenses tallied within this memo.

Although the pedestrian curb ramps were not assessed within Improvement District 2290, Attachment B does reference the cost of this work for transparency purposes.

In the upcoming months, City staff are preparing to bring back to the City Commission mill & overlay projects currently scheduled to be constructed in 2026, with two of them to be designed by a consultant and publicly bid to the contracting community for construction of the improvements. Additionally, according to the 2024 CIP, a mill & overlay project is planned for the core area, to be constructed and financed similarly to the current Improvement District 2290 project utilizing Public Works Department staff and equipment for the installation of the asphalt.

Regarding pedestrian ramps, City staff recommend that all pedestrian ramps within any future mill & overlay project's Improvement District be publicly bid, constructed by a contractor, and the costs included in the proposed assessments for the project.

Mill and Overlay Project 2290 – Public Works Paving

City of West Fargo – Public Works Department

Prepared by: Matthew Andvik, Senior Director of Public Works

Project Overview

Improvement District No. 2290 was initiated in response to multiple resident requests due to the deteriorating condition of the pavement in the area. Public Works crews had been performing frequent patching to maintain drivability, highlighting the urgent need for a comprehensive mill and overlay project.

City crews completed the paving over **14 working days**, with several delays due to weather, vendor issues, and asphalt plant breakdowns. Despite these setbacks, the project was completed efficiently and with significant cost savings by utilizing in-house labor and equipment.

Labor and Equipment Cost Methodology

- **Labor Costs** were calculated using total hourly rates, including base pay and benefits. A **37% benefit rate** was applied to regular pay and **22% to overtime**, based on the highest individual benefit rate among employees.
 - **Equipment Costs** included:
 - Purchase price
 - Resale/trade-in value
 - Depreciation
 - Repairs (parts and labor)
 - Fuel
 - For equipment calculated per mile, **10 miles/day** was used.
 - **Electronic message boards** were calculated by daily rates:
 - 2 units for 50 days
 - 1 unit for 43 days
 - 1 unit for 36 days
-

Project Delays and Adjustments

- **1 full day** lost to rain
 - **3 partial days** impacted by rain
 - **2 days** affected by asphalt plant breakdowns
 - **1 day** delayed due to tack oil supply issues
 - **1 week** delay due to unavailability of specified asphalt mix (Aug 28 – Sep 4)
-

Price Per Ton Analysis

- Total Asphalt Used: 6,547.89 tons
- Total Paving Material Cost: \$551,055.18
- Average Price per Ton: \$84.16

Average Asphalt Cost per Ton (Paving):

$\$551,055.18 \div 6,547.89 \approx \$84.16/\text{ton}$

Cost Summary by Activity

	Labor	Equipment	City Cost
Milling	\$ 14,913.20	\$ 5,403.82	\$ 20,317.02
Patching	\$ 22,142.19	\$ 5,066.49	\$ 27,208.68
Paving	\$ 90,411.75	\$ 27,557.26	\$ 117,969.01
Traffic Control	\$ 6,988.24	\$ 458.15	\$ 7,446.39
Project Totals	\$ 134,455.38	\$ 38,485.72	\$ 172,941.10

Out-of-Scope Work – Task ID 132890

Task 132890 involved emergency patching not included in the original scope. This work was completed in-house to avoid:

- Contractor mobilization costs
- Overhead/profit markups
- Scheduling delays

Summary of Task 132890:

- **Labor + Equipment:** \$19,083.56
 - **Materials:** \$15,476.84
 - **Total Cost: \$34,560.41**
 - **Asphalt Used:** 210 tons
 - **Tack Oil:** 25 gallons
-

*AI was used to assist in formatting this report.

Attachment B - Engineering Analysis of As-Installed Costs

Activity	Public Works			Materials	2290 Contract		PW Mat. & 2290 Cont.	
	Labor	Equipment	Labor & Equip.		Construction	Soft Costs	Mats. + CAP's + SC's	
Milling (Trucking)	\$14,913.20	\$5,403.82	\$20,317.02				\$0.00	
Patching	\$22,142.19	\$5,066.49	\$27,208.68	\$3,755.50			\$3,755.50	
Paving	\$90,411.75	\$27,557.26	\$117,969.01	\$16,775.15			\$16,775.15	
Traffic Control	\$6,988.24	\$458.15	\$7,446.39				\$0.00	
Contractor's Application for Payment - 1-3					\$915,789.46		\$915,789.46	
Contractor's Application for Payment - Final					\$172.15		\$172.15	
Engineering (Design/Construction) (10%)						\$91,596.16	\$91,596.16	
Consultant (Materials Testing)						\$3,000.00	\$3,000.00	
Legal & Administration (5%)						\$45,798.08	\$45,798.08	
Bonding/Interest (4%)						\$36,638.46	\$36,638.46	
Project Totals	\$134,455.38	\$38,485.72	\$172,941.10	\$20,530.65	\$915,961.61	\$177,032.71	\$1,113,524.97	
Labor & Equip. + PW Materials & 2290 Contract								\$1,286,466.07
50% of PW Materials & 2290 Contract								\$556,762.48
50% of PW Materials & 2290 Contract								\$556,762.48

Potential Estimated Special Assessments

Standard

Single Family Home	\$1,550
Twin Home	\$925
Condo / Town Home	\$475

If Curb Ramps Were Included*

Single Family Home	\$2,025
Twin Home	\$1,225
Condo / Town Home	\$625

* Curb Ramps were constructed in the Project 2291 - 2025 Concrete Pavement Repairs project.

Source of Funds (From Engineer's Report dated 12-12-2024)

Special Assessments (50% Expenditures)	\$572,500.00
City Funds - Capital Impr. Sales Tax (50% Expenditures)	\$572,500.00
<u>City Funds - General Fund (100% Labor & Equip.)</u>	\$155,000.00
Total	\$1,300,000.00

Communicated Estimated Special Assessments in Mailed 1-9-2025 Notice of Potential Assessed Improvements Impacting Your Property

Single Family Home	\$1,600
Twin Home	\$1,000
Condo / Town Home	\$500

Estimate of Probable Cost

Construction		\$1,090,000
Bid Proposal Items	\$991,000	
Contingency (~10%)	\$ 99,000	
Engineering (Design/Construction) (10%)		\$109,000
Consultant (Materials Testing)		\$3,000
Legal & Administration (5%)		\$55,000
Bonding/Interest (4%)		\$43,000
<hr/>		
Total Estimated Cost		\$1,300,000

Source of Funds

Special Assessments (50% Expenditures)	\$572,500
City Funds - Capital Impr. Sales Tax (50% Expenditures)	\$572,500
City Funds - General Fund (100% City Labor & Equip.)	\$155,000
<hr/>	
Total	\$1,300,000

Supporting Documents (available upon request)

- A. Itemized Estimate of Probable Cost
- B. Maps, Drawings, Etc.

The proposed improvements are cost effective and will adhere to city policies as well as applicable state and/or federal regulations.

Dan Hanson
 Daniel R. Hanson, P.E.
 ND Registration No. 4962



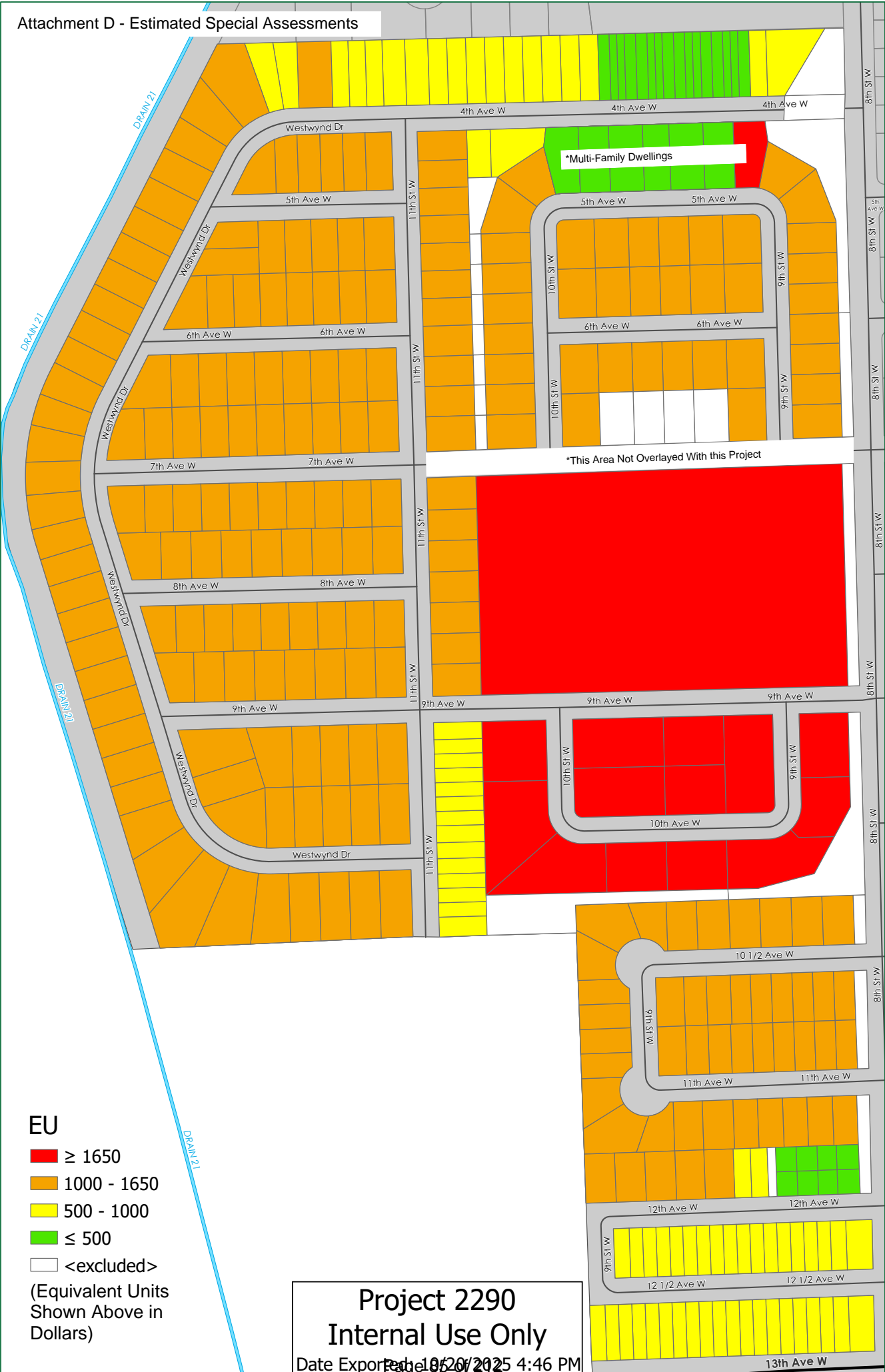

EU
 ■ ≥ 1650
 ■ 1000 - 1650
 ■ 500 - 1000
 ■ ≤ 500
 □ <excluded>
 (Equivalent Units
 Shown Above in
 Dollars)

Project 2290
Internal Use Only
 Date Exported: 10/20/2025 4:46 PM



Monthly Financial Statement
 Year To Date As of 11/30/2025
 Prepared on 12/04/2025

Prepared by: Sheila Olson
 Reviewed by: Willy Galindo
 Commission Meeting: 12/15/2025

Budgeted Funds:		Notes	Revenue/Transfers			Expenditure/Transfers			Net Actuals	Cash
Fund	Description		Actual	Annual Budget	% Received	Actual	Annual Budget	% Spent	Revenue vs. Expense	Balance
1000	General Fund		\$ 31,178,235	\$ 39,947,752	78%	\$ 35,437,336	\$ 41,572,202	85%	\$ (4,259,101)	\$ 7,858,239
2030	Share of Specials		228,280	221,833	103%	213,247	221,833	96%	15,034	118,701
7000	Library		2,727,516	2,651,523	103%	2,186,689	2,624,900	83%	540,827	1,632,926
7050	Airport		402,153	238,999	168%	473,586	485,945	97%	(71,433)	873,238
Total Government			\$ 34,536,185	\$ 43,060,107	80%	\$ 38,310,857	\$ 44,904,880	85%	\$ (3,774,673)	\$ 10,483,106
2970	Capital Improvements Sales Tax		\$ 10,524,867	12,281,488	86%	\$ 279,328	18,189,566	2%	10,245,539	38,009,132
2975	Public Safety Sales Tax		3,494,785	4,014,700	87%	38,307	4,869,513	1%	3,456,479	6,179,874
2971	Prairie Dog Funds		7,331,225	10,500,000	70%	-	10,500,000	0%	7,331,225	10,710,081
2960	Economic Development Sales Tax		3,569,951	4,109,700	87%	670,879	3,481,400	19%	2,899,072	18,825,428
2973	Flexible Transportation Fund		678,120	-	0%	-	-	0%	678,120	678,120
2110	Gaming		32,588	15,000	217%	-	18,000	0%	32,588	173,468
2XXX	Event Funds		-	-	0%	-	-	0%	-	16,668
2200	Vector Control	2	205,413	210,000	98%	146,483	100,000	146%	58,930	629,562
2210	Forestry	3	623,995	674,815	92%	847,594	840,940	101%	(223,599)	(3,658)
2230	City Utility		49,254	81,000	61%	-	50,000	0%	49,254	328,014
25XX	Police Special Funds	4	176,810	5,500	3215%	127,749	11,850	1078%	49,060	411,825
2950	Assets Forfeitures		27,933	30,000	93%	776	30,000	3%	27,157	154,804
2980	South Facility Hookup		-	50,000	0%	-	-	0%	-	3,694,308
Total Special Funds			\$ 26,714,943	\$ 31,972,203	84%	\$ 2,111,116	\$ 38,091,269	6%	\$ 24,603,827	\$ 79,807,627
3000	Total Debt Service		\$ 23,858,590	\$ 20,408,271	117%	\$ 27,912,918	\$ 24,157,135	116%	\$ (4,054,328)	\$ 51,920,779
6010	Sanitation		\$ 7,018,696	\$ 7,100,000	99%	\$ 6,328,938	\$ 7,780,975	81%	\$ 689,758	\$ 2,303,198
6020	Water		10,987,522	10,500,000	105%	9,393,680	9,832,542	96%	1,593,842	9,751,765
6025	Sewer		7,064,869	8,102,130	87%	7,007,894	7,699,497	91%	56,975	(497,827)
Total Enterprise			25,071,086	25,702,130	98%	22,730,511	25,313,014	90%	2,340,575	\$ 11,557,136
5000	Tree Fund		\$ 22,973	\$ 50,000	46%	\$ 39,310	\$ 50,000	79%	\$ (16,338)	554,399
2050	Park Funds/State Aid		1,072,649	1,128,681	95%	1,072,649	1,128,681	95%	-	110,361
8600	Park District Special Assessment		\$ 740,390	\$ 720,242	103%	742,106	720,242	103%	(1,715)	4,718
2141	FM CVB		456,185	383,000	119%	426,947	383,000	111%	29,238	43,388
Total Agency			\$ 2,292,198	\$ 2,281,923	100%	\$ 2,281,013	\$ 2,281,923	100%	\$ 11,185	\$ 712,865
Total All Budgeted Funds			\$ 112,473,002	\$ 123,424,634	91%	\$ 93,346,415	\$ 134,748,221	69%	\$ 19,126,586	\$ 154,481,514
Non-Budgeted Funds:		Notes	Revenue/Transfers			Expenditure/Transfers			Net Actuals	Cash
Fund	Description		Actual	Annual Budget	Variance	Actual	Annual Budget	Variance	Revenue vs. Expense	Balance
4000	Construction		\$ 5,713,691	\$ 1,733,766	330%	\$ 28,491,254	\$ 1,733,766	1643%	\$ (22,777,563)	\$ (43,977,945)
2170	Clerk of Court Bond Fund		-	-	0%	-	-	0%	-	75,854
2XXX	Misc. Special Funds	5	451,578	655,317	69%	890,637	1,177,706	76%	(439,060)	712,036
7XXX	Agency Funds		-	-	0%	-	-	0%	-	218,391
8000	West Fargo Parks Payroll		-	-	0%	-	-	0%	-	(6,516)
Total Non-Budgeted Funds			\$ 6,165,268	\$ 2,389,083	258%	\$ 29,381,891	\$ 2,911,472	1009%	\$ (23,216,622)	\$ (42,978,180)
Total All Funds Combined			\$ 118,638,270	\$ 125,813,717	94%	\$ 122,728,306	\$ 137,659,693	89%	\$ (4,090,036)	\$ 111,503,334

Notes:

1	Transfers to revenue will be processed at year-end.
2	Increase in spray costs due to high volume of mosquitos.
3	Bucket truck brought forward from 2026 to 2025 to save on potential tariff costs.
4	Funds received for Back the Blue Grant. Equipment fund used to purchase two vehicles.
5	Transfers to revenue will be processed at year-end.



To: West Fargo City Commission

From: Matt Andvik, Senior Public Works Director
Logan Jacobson, Director of Public Works Services

Date: December 15th, 2025

Subject: Addendum to 2026 Sanitation Fees

Action: Approve Specialty Item Mattress Fee Addition

Commission President

Bernie Dardis

Primary Portfolio:
Administrative Services

Secondary Portfolio:
Police & Fire

Commission Vice President

Brad Olson

Primary Portfolio:
Police & Fire

Secondary Portfolio:
Street, Water & Sewer

Commissioner

Roben Anderson

Primary Portfolio:
Community & Development Services

Secondary Portfolio:
Administrative Services

Commissioner

Amy Zundel

Primary Portfolio:
Street, Water & Sewer

Secondary Portfolio:
Sanitation

Commissioner

Rory Jorgensen

Primary Portfolio:
Sanitation

Secondary Portfolio:
Community & Development Services

City Administrator

Dustin Scott

Summary and Recommendation:

As part of a planned rate increase, The City of Fargo passed a mattress disposal fee of \$15.00 (plus tipping fee) on November 24, 2025.

The City of West Fargo collects mattresses through several programs:

- Commercial roll-off services
- Commercial dumpster collection
- Transfer Station drop-off
- Residential bulky item collection

All collected MSW waste, including mattresses, is hauled by the Sanitation Department to the Fargo Landfill for disposal. As a result, the new fee directly affects the City of West Fargo's operational costs.

To offset the new disposal cost, the Sanitation Department recommends implementing a \$15.00 mattress disposal fee for all mattresses collected by the City of West Fargo, across all applicable programs.

This fee would ensure cost recovery and maintain the sustainability of waste collection services. The Sanitation Department would follow the same procedure for processing mattress billing as for appliance billing.

Policy Analysis:

Effective January 1, 2026, the City of Fargo Landfill will begin charging a \$15.00 commercial mattress disposal fee, in addition to the standard tipping fee. This change affects all entities disposing of mattresses at the landfill, including the City of West Fargo Sanitation Department.

Impacted Services in West Fargo:

- **Commercial Roll-Off Services:**
Mattresses collected via commercial roll-off services will incur the \$15.00 disposal fee, added directly to the scale ticket at the Fargo Landfill and passed on directly to location.
- **Residential Bulky Item Collection:**
Initiated in July 2024, this program was approved at the January 22, 2024, commission meeting. At that time, no additional costs were assigned to furniture, branches, or mattress disposal. Specialty items, such as appliances, were assigned per-unit fees. Residents will now incur the \$15.00 mattress disposal fee.
- **Multi-Family/Mixed Use/Commercial Dumpster Services:**
Mattresses collected from these properties are hauled to the Fargo Landfill and will now incur the \$15.00 mattress disposal fee.
- **Transfer Station Drop-Off:**
Residents dropping off mattresses at the Transfer Station will now be required to follow the same process for the mattresses as with appliances and will incur the \$15.00 mattress disposal fee.

Rate History:

- February 7, 2024: Resolution setting 2024 rates approved.
- October 7, 2024: 2025 rates updated; specialty item fees for tires introduced.
- July 21, 2025: 2026 rates approved.

Most bulky items, such as furniture, are disposed of at the City of West Fargo Inert Landfill. The Inert Landfill does not accept mattresses. Mattresses must be hauled to the Fargo Landfill and will now incur a \$15.00 per unit fee.

Financial Analysis:

The Sanitation Department estimates about 750 mattresses are collected by the bulky collection program and Transfer Station drop off. The financial impact of disposing of 750 mattresses at \$15.00 per unit is \$11,250.00.

The residential bulky item collection program disposed of mattresses from 188 homes in West Fargo to date in 2025. Transfer Station drop offs are estimated at 10 mattresses per week. Multi-family housing collection data is currently unavailable and estimated costs are unknown.

With the approval of the mattress disposal fee, specialty item fees will be as follows:

Item	Fee
Mattress (any size)	\$15
Non-Freon Appliance	\$25
Freon Appliance	\$60
Exercise/Lawn Equipment	\$25
Car Tire ≤ 17"	\$10
Car Tire w/ Rim	\$15
Pickup Tire ≥ 18"	\$15
Pickup Tire w/ Rim	\$25
Race Tire	\$15
Race Tire w/ Rim	\$25

Process/Timeline:

The \$15.00 mattress disposal fee would go into effect January 1, 2026. Staff will update the website, bulky collection program online information, and Transfer Station signage.

GRANT AGREEMENT

This Agreement is made by and between the North Dakota Department of Corrections and Rehabilitation and its Division of Juvenile Services (DJS) (STATE), the North Dakota Association of Counties (NDACo), city and county jurisdictions as listed in Appendix A (JURISDICTIONS), and Youthworks (GRANTEE), Unique Entity Identifier # KCSJVSNHZZL5.

WHEREAS, DJS has determined the Attendant Care services referred to in the paragraph below entitled "Scope of Services" form an appropriate basis for the expenditure of Federal grant funds (CFDA number 16.540) from the Office of Juvenile Justice and Delinquency Prevention (OJJDP); and

WHEREAS, NDACo has agreed to assist DJS in obtaining, coordinating, and administrating these services; and

WHEREAS, JURISDICTIONS have identified and support GRANTEE as an agency authorized to provide services for youth picked up by law enforcement that need a temporary placement option;

WHEREAS, GRANTEE is an appropriate agency to provide Attendant Care services for delinquent youth as defined in the North Dakota Attendant Care Program Guidelines (Guidelines), found at https://www.ndaco.org/programs_and_services/jj/statewide-detention-support-services-sdss/, as well as short-term shelter services for Children in Need of Services (CHINS).

NOW, THEREFORE, the parties agree as follows:

AGREEMENT

I. TERM OF THE AGREEMENT

The term of this agreement shall be from January 1, 2026 through December 31, 2026. This agreement supersedes all previous agreements associated with the scope of services.

II. SCOPE OF SERVICES

The GRANTEE shall:

1. Provide a placement facility that law enforcement can access twenty-four hours a day, seven days a week for delinquent and CHINS youth who need a non-secure short-term placement option;
2. Provide Attendant Care services to delinquent youth in conformance with all provisions of the Guidelines, including the development of policies and procedures for the supervision of youth;
3. Screen youth for appropriateness, including assessing for immediate mental health needs, history of violence and/or sexual aggression, and current affect and behavior;
4. Notify the Juvenile Court of any delinquent youth placed in the facility within 24 hours of being placed;
5. Submit to NDACo all reports and documentation required by the Guidelines; and

6. Allow NDACo to conduct on-site programmatic monitoring of the Attendant Care services, as required pursuant to federal guidelines.

Youth may need to be medically-cleared prior to entry into the facility and/or may not be appropriate due to aggressive behaviors that are likely to occur while at the facility (threatening or aggressive behavior, or non-compliance with the staff).

In the event that more than two youth are referred for placement at the same time, GRANTEE will make every effort to take the additional youth. GRANTEE may provide services to other agencies, but priority will be given to the JURISDICTIONS. GRANTEE will bill a daily rate to those jurisdictions that are not part of this agreement and will track all money collected for purposes of subsequent contract periods.

Grantee will provide placement data, to include the number of youth placed by jurisdiction, on an annual basis. Grantee will provide financial reporting for the 2025 calendar year by January 30, 2026.

III. COMPENSATION

DJS, through NDACo, shall provide reimbursement to the GRANTEE for Attendant Care services outlined in the Guidelines.

JURISDICTIONS shall provide funding, as outlined in Appendix A, to GRANTEE to cover Attendant Care expenses not eligible for reimbursement pursuant to the Guidelines as well as the costs associated with providing shelter services to Children in Need of Services.

The GRANTEE agrees to account for any and all grant funds that may be in possession of the GRANTEE throughout the term of this grant and to return any unexpended funds within 30 days after final closing of the grant.

IV. GRANTEE ASSURANCES

The GRANTEE agrees to comply with North Dakota Century Code chapters 27-20.2, 27-20.3, and 27-20.4, and the applicable grant conditions and assurances established by OJJDP for subgrant recipients of these federal funds as fully detailed in Appendix B.

The GRANTEE agrees to comply (and will require any subgrantees or contractors to comply) with any applicable federal nondiscrimination requirements, which may include the Omnibus Crime Control and Safe Streets Act of 1968 (34 USC § 10228(c) & 10221(a)); the Juvenile Justice and Delinquency Prevention Act of 2002 (34 USC § 11182(b)); 28 CFR Part 42 (U.S. Department of Justice Regulations – Nondiscrimination; Equal Employment Opportunity; Policies and Procedures), including Title VI of the Civil Rights Act of 1964, as amended, Section 815(c)(1) of the Justice System Improvement Act of 1979, Equal Employment Opportunity Program Guidelines, Section 504 of the Rehabilitation Act of 1973, as amended, and the Age Discrimination Act of 1975; the Americans with Disabilities Act of 1990 (42 USC §§ 12131-34); Title IX of the Education Amendments of 1972 (20 USC §§ 1681, 1683, 1685-86); and 28 CFR Part 38 (U.S. Department of Justice Regulations – Partnerships with Faith-Based and Other Neighborhood Organizations).

To ensure compliance with the Omnibus Crime Control and Safe Streets Act of 1968 and Title VI of the Civil Rights Act of 1964, GRANTEE agrees to take steps to ensure the persons with Limited English Proficiency (LEP) have meaningful access to its programs. Meaningful access may entail providing language assistance, including oral and written translation, where necessary. GRANTEE is encouraged to consider the need for language services for LEP persons both in developing its budgets and in conducting its programs and activities. Additional information regarding LEP obligations can be found at <http://www.lep.gov>.

The GRANTEE agrees to designate a civil rights contact person who has lead responsibility in insuring that all applicable civil rights requirements, assurances, and conditions are met and who shall act as a liaison in all civil rights matters with the Office of Juvenile Justice and Delinquency Prevention, Office of Justice Programs and the Office for Civil Rights, Office of Justice Programs.

The GRANTEE is required to complete Federal Civil Rights Non-Discrimination Training developed the Office of Civil Rights (OCR) found at www.ojp.gov/program/civil-rights/video-training-grantees/overview.

The GRANTEE will inform the public and subgrantees of affected persons' rights to file a complaint of discrimination with the Office for Civil Rights, Office of Justice Programs for investigation. In the event a Federal or State court or Federal or State administrative agency makes a finding of discrimination after a due process hearing on the grounds of race, color, religion, national origin, or sex against a recipient of funds, the recipient will forward a copy of the finding to the Office for Civil Rights, Office of Justice Programs and the North Dakota Department of Corrections and Rehabilitation, Division of Juvenile Services (DJS).

The GRANTEE will develop an Equal Employment Opportunity Plan (EEO) if it is a government agency or private business that is receiving an award of \$25,000 or greater and has 50 or more employees.

The GRANTEE shall not retaliate against individuals for taking action or participating in action to secure rights protected by the above referenced laws.

V. **AUTHORITY TO CONTRACT**

The GRANTEE shall not have the authority to contract on behalf of or incur obligations on behalf of NDACo or DJS without written approval of NDACo and DJS. If such subcontract is approved, it shall acknowledge the binding nature of this agreement, and incorporate this agreement, together with its attachments as appropriate.

VI. **INDEPENDENT ENTITY**

The GRANTEE shall perform as an independent entity under this agreement. The GRANTEE, its employees, agents or representatives are not employees of NDACo or DJS. No part of this agreement shall be construed to represent the creation of an employer/employee relationship.

VII. **AUDIT RESPONSIBILITY**

The GRANTEE agrees to keep such financial records as are required for sub-grants of OJJDP

grant awards, as detailed in the Office of Justice Programs, Financial Guide and associated Federal Circulars. These records shall be made available to NDACo, DJS, or their agents, upon request at any time during normal business hours. The GRANTEE agrees to include these funds in the annual audit of its organization, and further agrees to allow NDACo, DJS, or their agents, to conduct an audit at the expense of NDACo, DJS, or their agents.

VIII. RETENTION/PRIVACY OF RECORDS

The GRANTEE agrees to retain the financial records identified in paragraph VII above, for a period of three years or until an audit is completed and closed, whichever occurs later. The GRANTEE further agrees to assure the privacy and confidentiality of client records in conformance with all applicable State and federal laws and regulations. The GRANTEE understands that except for the records that are confidential or that have been identified as exempt, this Agreement, and any records generated pursuant to this Agreement may be subject to disclosure under applicable state and federal law.

IX. TERMINATION OF AGREEMENT

If through good cause, the GRANTEE shall fail to fulfill in a timely and proper manner its obligations under this agreement, NDACo or DJS shall thereupon have the right to terminate this agreement by giving written notice 30 days prior to termination to the GRANTEE of such termination. Notwithstanding a termination pursuant to this paragraph, the GRANTEE shall not be relieved of liability to NDACo or DJS, and NDACo or DJS may withhold any payment otherwise due to the GRANTEE.

DJS and NDACo may terminate this Agreement upon delivery of written notice to the GRANTEE, or on any later date stated on the notice under any of the following conditions:

- a. If funding from federal, state, or other sources is not obtained and continued at levels sufficient for the services specified in the Agreement. The Agreement may be modified by the consent of the parties in writing to accommodate any reduction in funds;
- b. If federal or state laws or rules are modified or interpreted in a way that the funding or services are no longer allowable or appropriate or are no longer eligible for funding or payment authorized by this Agreement;
- c. If any license, permit or certificate required by rule or law, or by the terms of the Agreement between the parties, is for any reason denied, revoked, suspended or not renewed.

X. INTERACTING AND MODIFICATION

This agreement constitutes the entire agreement between the GRANTEE, NDACo and DJS. No alteration or amendment shall be effective unless it is reduced to writing, signed by the parties and attached hereto.

XI. APPLICABLE LAW

This agreement shall be governed by and construed in accordance with the laws of the state of North Dakota.

XII. CAPTIONS

The captions or headings in this agreement are for convenience only and in no way define, limit or describe the scope or intent of any provisions of this agreement.

XIII. EXECUTION AND COUNTERPARTS

This agreement may be executed in several counterparts, each of which shall be an original, all of which shall constitute but one and the same instrument.

XIV. NOTICES

All notices, certificates or other communications shall be sufficiently given when delivered or mailed, postage prepaid, to the parties at their respective places of business.

XV. ASSIGNMENT

This agreement shall not be assigned or transferred without the expressed written consent of the parties.

XVI. SUCCESSORS IN INTEREST

The provisions of the agreement shall be binding upon and shall inure to the benefit of the parties hereto, their respective successors and permitted assigns.

XVII. FORCE MAJEURE

The GRANTEE shall not be held responsible for delay or default caused by fire, riot, acts of God and war and other events that are beyond the GRANTEE's reasonable control, provided notice is given to NDACo and DJS of any such delay or default.

XVIII. SEVERABILITY

The parties agree that if any term or provision of this agreement is declared by a court of competent jurisdiction to be illegal or in conflict with any law, the validity of the remaining terms and provisions shall not be affected, and the rights and obligations of the parties shall be construed and enforced as if the agreement did not contain the particular term or provision held to be invalid.

XIX. INDEMNITY

GRANTEE agrees to defend, indemnify, and hold harmless the State of North Dakota, its agencies, officers and employees (STATE), from and against claims based on the vicarious liability of the STATE or its agents, but not against claims based on the STATE'S contributory negligence, comparative and/or contributory negligence or fault, sole negligence, or intentional misconduct. This obligation to defend, indemnify, and hold harmless does not extend to professional liability claims arising from professional errors and omissions. The legal defense provided by GRANTEE for the STATE under this provision must be free of any conflicts of interest, even if retention of separate legal counsel for the STATE is necessary. Any attorney appointed to represent the STATE must first qualify as and be appointed by the North Dakota Attorney General as a Special Assistant Attorney General as required under N.D.C.C. § 54-12-08. GRANTEE also agrees to reimburse the STATE for all costs, expenses and attorneys' fees incurred if the STATE prevails in an action against GRANTEE in establishing and litigating the indemnification coverage provided herein. This obligation shall continue after the termination of this Contract.

XX. INSURANCE

If GRANTEE is a political subdivision, then GRANTEE shall have liability coverage pursuant to N.D.C.C. 32-12.1. If GRANTEE is not a political subdivision then GRANTEE shall secure and keep in force during the term of this Contract and GRANTEE shall require all subcontractors, prior to commencement of an agreement between GRANTEE and the subcontractor, to secure and keep in force during the term of this Contract, from insurance companies, government self-insurance pools or government self-retention funds, authorized to do business in North Dakota, the following insurance coverages:

1. Commercial general liability, including premises or operations, contractual, and products or completed operations coverages (if applicable), with minimum liability limits of \$2,000,000 per occurrence.
2. Automobile liability, including Owned (if any), Hired, and Non-Owned automobiles, with minimum liability limits of \$500,000 per person and \$2,000,000 per occurrence.
3. Workers compensation coverage meeting all statutory requirements. The policy shall provide coverage for all states of operation that apply to the performance of this Contract.

The insurance coverages listed above must meet the following additional requirements:

1. Any deductible or self-insured retention amount or other similar obligation under the policies shall be the sole responsibility of the GRANTEE.
2. This insurance may be in policy or policies of insurance, primary and excess, including the so-called umbrella or catastrophe form and must be placed with insurers rated "A- "or better by A.M. Best Company, Inc., provided any excess policy follows form for coverage. Less than an "A- "rating must be approved by the STATE. The policies shall be in form and terms approved by the STATE.
3. The duty to defend, indemnify, and hold harmless the STATE under this Contract shall not be limited by the insurance required in this Contract.
4. The State of North Dakota and its agencies, officers, and employees (STATE) shall be endorsed on the commercial general liability policy, including any excess policies (to the extent applicable), as additional insured. The STATE shall have all the benefits, rights and coverages of an additional insured under these policies that shall not be limited to the minimum limits of insurance required by this Contract or by the contractual indemnity obligations of the GRANTEE.
5. A "Waiver of Subrogation" waiving any right to recovery the insurance company may have against the STATE.
6. The GRANTEE shall furnish a certificate of insurance to the undersigned State representative prior to commencement of this Contract. All endorsements shall be provided as soon as practicable.
7. Failure to provide insurance as required in this Contract is a material breach of contract entitling the STATE to terminate this Contract immediately.
8. GRANTEE shall provide at least 30-day notice of any cancellation or material change to the policies or endorsements. GRANTEE shall provide on an ongoing basis, current certificates of insurance during the term of this Contract. A renewal certificate will be provided 10 days prior to coverage expiration.

XXI. SPOILATION

GRANTEE shall promptly notify STATE of all potential claims that arise or result from this Contract. GRANTEE shall also take all reasonable steps to preserve all physical evidence and information that may be relevant to the circumstances surrounding a potential claim, while maintaining public safety, and grants to STATE the opportunity to review and inspect the evidence, including the scene of an accident.

GRANTEE:

CERTIFICATION REGARDING DEBARMENT, SUSPENSION, INELIGIBILITY, AND VOLUNTARY EXCLUSION FOR LOWER TIER COVERED TRANSACTIONS

This certification is required by the regulations implementing Executive Order 12549, Debarment and Suspension, 28 C.F.R. Part 67, Section 67.510, Participants' responsibilities. The regulations were published as Part VII of the May 26, 1988, Federal Register (pages 19160-19211).

1. The prospective lower tier participant certifies, by submission of this proposal, that neither it nor its principals are presently debarred, suspended, proposed for debarment, declared ineligible, or voluntarily excluded from participation in this transaction by any federal department or agency.
2. Where the lower tier participant is unable to certify to any of the statements in this certification, such prospective participant shall attach an explanation to this proposal.

Youthworks

Mark Heinert, Executive Director

Date

Signatures

In Witness Whereof the parties hereto have entered into this Agreement as evidenced by their signatures below:

For the Department of Corrections and Rehabilitation:

Michele Zander, Chief Financial Officer

Date

For the North Dakota Association of Counties:

Aaron Birst, Executive Director

Date

For Barnes County:

Commission Chair

Date

For Cass County:

Commission Chair

Date

For Dickey County:

Commission Chair

Date

For Foster County:

Commission Chair

Date

For Griggs County:

Commission Chair

Date

For LaMoure County:

Commission Chair

Date

For Ransom County:

Commission Chair

Date

For Stutsman County Sheriff's Office:

Sheriff

Date

For Traill County:

Commission Chair

Date

For City of Fargo:

Mayor

Date

For City of West Fargo:

Mayor

Date

For Youthworks:

Executive Director

Date

APPENDIX A

PROPOSED BUDGET FOR 12 MONTHS	CALENDAR YEAR
FARGO L.E. SHELTER	2026
INCOME	
FARGO PD (CITY)	42,436.00
WEST FARGO PD (CITY)	37,132.00
CASS COUNTY	100,786.00
BARNES COUNTY	1,591.00
DICKEY COUNTY	1,591.00
FOSTER COUNTY	1,591.00
GRIGGS COUNTY	1,591.00
LAMOURE COUNTY	1,591.00
RANSOM COUNTY	1,591.00
STUTSMAN COUNTY SHERIFF'S OFFICE	1,591.00
TRAILL COUNTY	1,591.00
YOUTHWORKS FUNDRAISING FUNDS	25,000.00
ATTENDANT CARE PROGRAM (EST)	20,000.00
TOTAL INCOME	238,082.00
EXPENSES	
PERSONNEL FULL TIME	114,008.00
BENEFITS FULL TIME	39,004.00
OPERATIONAL COSTS (space, utilities, ins, repairs)	18,270.00
PART TIME SHELTER STAFF	66,800.00
TOTAL EXPENSES	238,082.00
NET INCOME	0.00

APPENDIX B

Grant Award Conditions**1**

Meaningful access requirement for individuals with limited English proficiency

The recipient, and any subrecipient at any tier, must take reasonable steps to ensure that individuals with limited English proficiency (LEP) have meaningful access to their programs and activities to comply with Title VI of the Civil Rights Act of 1964 (Title VI), which prohibits discrimination on the basis of national origin, including discrimination against individuals with LEP. Such steps may require providing language assistance services, such as interpretation or translation services. The Department of Justice guidance on compliance with this requirement may be found at "Guidance to Federal Financial Assistance Recipients Regarding Title VI Prohibition Against National Origin Discrimination Affecting Limited English Proficient Persons" (67 Fed. Reg. 41455-41472) (<https://www.federalregister.gov/d/02-15207>) and is incorporated by reference here.

2

Compliance with general appropriations-law restrictions on the use of federal funds (FY 2024)

The recipient, and any subrecipient ("subgrantee") at any tier, must comply with all applicable restrictions on the use of federal funds set out in federal appropriations statutes. Pertinent restrictions that may be set out in applicable appropriations acts are indicated at <https://ojp.gov/funding/Explore/FY24AppropriationsRestrictions.htm>, and are incorporated by reference here.

Should a question arise as to whether a particular use of federal funds by a recipient (or a subrecipient) would or might fall within the scope of an appropriations-law restriction, the recipient is to contact OJP for guidance, and may not proceed without the express prior written approval of OJP.

3

Compliance with DOJ regulations pertaining to civil rights and nondiscrimination - 28 C.F.R. Part 38

The recipient, and any subrecipient ("subgrantee") at any tier, must comply with all applicable requirements of 28 C.F.R. Part 38.

Among other things, 28 C.F.R. Part 38 states that recipients may not use direct Federal financial assistance from the Department to support or engage in any explicitly religious activities except when consistent with the Establishment Clause of the First Amendment and any other applicable requirements. An organization receiving Federal financial assistance also may not, in providing services funded by the Department of Justice, or in their outreach activities related to such services, discriminate against a program beneficiary or prospective program beneficiary on the basis of religion, a religious belief, a refusal to hold a religious belief, or refusal to attend or participate in a religious practice. Part 38 also sets out rules and requirements that pertain to recipient and subrecipient ("subgrantee") organizations that engage in or conduct explicitly religious activities, as well as rules and requirements that pertain to recipients and subrecipients that are faith-based or religious organizations. In addition, Part 38 states that a faith-based organization that participates a Department of Justice funded program retains its independence from the Government and may continue to carry out its mission consistent with religious freedom and conscience protections in Federal law.

Recipients and subrecipients that provide social services under this award must give written notice to beneficiaries and prospective beneficiaries prior to the provision of services (if practicable) which shall

include language substantially similar to the language in 28 CFR Part 38, Appendix C, sections (1) through (4). A sample written notice may be found at <https://www.ojp.gov/program/civil-rights-office/partnerships-faith-based-and-other-neighborhood-organizations>.

In certain instances, a faith-based or religious organization may be able to take religion into account when making hiring decisions, provided it satisfies certain requirements. For more information, please see <https://www.ojp.gov/funding/explore/legaloverview2024/civilrightsrequirements>.

4

Requirements of the award; remedies for non-compliance or for materially false statements

The conditions of this award are material requirements of the award. Compliance with any assurances or certifications submitted by or on behalf of the recipient that relate to conduct during the period of performance also is a material requirement of this award.

Limited Exceptions. In certain special circumstances, the U.S. Department of Justice ("DOJ") may determine that it will not enforce, or enforce only in part, one or more requirements otherwise applicable to the award. Any such exceptions regarding enforcement, including any such exceptions made during the period of performance, are (or will be during the period of performance) set out through the Office of Justice Programs ("OJP") webpage entitled "Legal Notices: Special circumstances as to particular award conditions" ([ojp.gov/funding/Explore/LegalNotices-AwardReqts.htm](https://www.ojp.gov/funding/Explore/LegalNotices-AwardReqts.htm)), and incorporated by reference into the award.

By signing and accepting this award on behalf of the recipient, the authorized recipient official accepts all material requirements of the award, and specifically adopts, as if personally executed by the authorized recipient official, all assurances or certifications submitted by or on behalf of the recipient that relate to conduct during the period of performance.

Failure to comply with one or more award requirements -- whether a condition set out in full below, a condition incorporated by reference below, or an assurance or certification related to conduct during the award period -- may result in OJP taking appropriate action with respect to the recipient and the award. Among other things, the OJP may withhold award funds, disallow costs, or suspend or terminate the award. DOJ, including OJP, also may take other legal action as appropriate.

Any materially false, fictitious, or fraudulent statement to the federal government related to this award (or concealment or omission of a material fact) may be the subject of criminal prosecution (including under 18 U.S.C. 1001 and/or 1621, and/or 34 U.S.C. 10271-10273), and also may lead to imposition of civil penalties and administrative remedies for false claims or otherwise (including under 31 U.S.C. 3729-3730 and 3801-3812).

Should any provision of a requirement of this award be held to be invalid or unenforceable by its terms, that provision shall first be applied with a limited construction so as to give it the maximum effect permitted by law. Should it be held, instead, that the provision is utterly invalid or -unenforceable, such provision shall be deemed severable from this award.

5

Effect of failure to address audit issues

The recipient understands and agrees that the DOJ awarding agency (OJP or OVW, as appropriate) may withhold award funds, or may impose other related requirements, if (as determined by the DOJ awarding agency) the recipient does not satisfactorily and promptly address outstanding issues from audits required by the Part 200 Uniform Requirements (or by the terms of this award), or other outstanding issues that arise in connection with audits, investigations, or reviews of DOJ awards.

6**Applicability of Part 200 Uniform Requirements**

The Uniform Administrative Requirements, Cost Principles, and Audit Requirements in 2 C.F.R. Part 200, as adopted and supplemented by DOJ in 2 C.F.R. Part 2800 (together, the "Part 200 Uniform Requirements") apply to this award from OJP.

For more information and resources on the Part 200 Uniform Requirements as they relate to OJP awards and subawards ("subgrants"), see the OJP website at <https://ojp.gov/funding/Part200UniformRequirements.htm>.

Record retention and access: Records pertinent to the award that the recipient (and any subrecipient ("subgrantee") at any tier) must retain -- typically for a period of 3 years from the date of submission of the final expenditure report (SF 425), unless a different retention period applies -- and to which the recipient (and any subrecipient ("subgrantee") at any tier) must provide access, include performance measurement information, in addition to the financial records, supporting documents, statistical records, and other pertinent records indicated at 2 C.F.R. 200.334.

In the event that an award-related question arises from documents or other materials prepared or distributed by OJP that may appear to conflict with, or differ in some way from, the provisions of the Part 200 Uniform Requirements, the recipient is to contact OJP promptly for clarification.

7**Reporting potential fraud, waste, and abuse, and similar misconduct**

The recipient, and any subrecipients ("subgrantees") at any tier, must promptly refer to the DOJ Office of the Inspector General (OIG) any credible evidence that a principal, employee, agent, subrecipient, contractor, subcontractor, or other person has, in connection with funds under this award-- (1) submitted a claim that violates the False Claims Act; or (2) committed a criminal or civil violation of laws pertaining to fraud, conflict of interest, bribery, gratuity, or similar misconduct.

Potential fraud, waste, abuse, or misconduct involving or relating to funds under this award should be reported to the OIG by--(1) online submission accessible via the OIG webpage at <https://oig.justice.gov/hotline/contact-grants.htm> (select "Submit Report Online"); (2) mail directed to: U.S. Department of Justice, Office of the Inspector General, Investigations Division, ATTN: Grantee Reporting, 950 Pennsylvania Ave., NW, Washington, DC 20530; and/or (3) by facsimile directed to the DOJ OIG Investigations Division (Attn: Grantee Reporting) at (202) 616-9881 (fax).

Additional information is available from the DOJ OIG website at <https://oig.justice.gov/hotline>.

8**Requirements related to "de minimis" indirect cost rate**

A recipient that is eligible under the Part 200 Uniform Requirements and other applicable law to use the "de minimis" indirect cost rate described in 2 C.F.R. 200.414(f), and that elects to use the "de minimis" indirect cost rate, must advise OJP in writing of both its eligibility and its election, and must comply with all associated requirements in the Part 200 Uniform Requirements. The "de minimis" rate may be applied only to modified total direct costs (MTDC) as defined by the Part 200 Uniform Requirements.

9

Compliance with applicable rules regarding approval, planning, and reporting of conferences, meetings, trainings, and other events

The recipient, and any subrecipient ("subgrantee") at any tier, must comply with all applicable laws, regulations, policies, and official DOJ guidance (including specific cost limits, prior approval and reporting requirements, where applicable) governing the use of federal funds for expenses related to conferences (as that term is defined by DOJ), including the provision of food and/or beverages at such conferences, and costs of attendance at such conferences.

Information on the pertinent DOJ definition of conferences and the rules applicable to this award appears in the DOJ Grants Financial Guide (currently, as section 3.10 of "Postaward Requirements" in the "DOJ Grants Financial Guide").

10

Requirement for data on performance and effectiveness under the award

The recipient must collect and maintain data that measure the performance and effectiveness of work under this award. The data must be provided to OJP in the manner (including within the timeframes) specified by OJP in the program solicitation or other applicable written guidance. Data collection supports compliance with the Government Performance and Results Act (GPRA) and the GPRA Modernization Act of 2010, and other applicable laws.

11

Compliance with DOJ Grants Financial Guide

References to the DOJ Grants Financial Guide are to the DOJ Grants Financial Guide as posted on the OJP website (currently, the "DOJ Grants Financial Guide" available at <https://ojp.gov/financialguide/DOJ/index.htm>), including any updated version that may be posted during the period of performance. The recipient agrees to comply with the DOJ Grants Financial Guide.

12

Compliance with DOJ regulations pertaining to civil rights and nondiscrimination - 28 C.F.R. Part 42

The recipient, and any subrecipient ("subgrantee") at any tier, must comply with all applicable requirements of 28 C.F.R. Part 42, specifically including any applicable requirements in Subpart E of 28 C.F.R. Part 42 that relate to an equal employment opportunity program.

Among other items, 28 C.F.R. § 42.106(d), 28 C.F.R. § 42.405(c), and 28 C.F.R. § 42.505(f) contain notice requirements that covered recipients must follow regarding the dissemination of information regarding federal nondiscrimination requirements.

13

Determination of suitability to interact with participating minors

SCOPE. This condition applies to this award if it is indicated -- in the application for the award (as approved by DOJ)(or in the application for any subaward, at any tier), the DOJ funding announcement (solicitation), or an associated federal statute -- that a purpose of some or all of the activities to be carried out under the award (whether by the recipient, or a subrecipient at any tier) is to benefit a set of individuals under 18 years of age.

The recipient, and any subrecipient at any tier, must make determinations of suitability before certain individuals may interact with participating minors. This requirement applies regardless of an individual's employment status.

The details of this requirement are posted on the OJP web site at <https://ojp.gov/funding/Explore/Interact-Minors.htm> (Award condition: Determination of suitability required, in advance, for certain individuals who may interact with participating minors), and are incorporated by reference here.

14

Requirement to disclose whether recipient is designated "high risk" by a federal grant-making agency outside of DOJ

If the recipient is designated "high risk" by a federal grant-making agency outside of DOJ, currently or at any time during the course of the period of performance under this award, the recipient must disclose that fact and certain related information to OJP by email at OJP.ComplianceReporting@ojp.usdoj.gov. For purposes of this disclosure, high risk includes any status under which a federal awarding agency provides additional oversight due to the recipient's past performance, or other programmatic or financial concerns with the recipient. The recipient's disclosure must include the following: 1. The federal awarding agency that currently designates the recipient high risk, 2. The date the recipient was designated high risk, 3. The high-risk point of contact at that federal awarding agency (name, phone number, and email address), and 4. The reasons for the high-risk status, as set out by the federal awarding agency.

15

Employment eligibility verification for hiring under the award

1. The recipient (and any subrecipient at any tier) must--

A. Ensure that, as part of the hiring process for any position within the United States that is or will be funded (in whole or in part) with award funds, the recipient (or any subrecipient) properly verifies the employment eligibility of the individual who is being hired, consistent with the provisions of 8 U.S.C. 1324a(a)(1).

B. Notify all persons associated with the recipient (or any subrecipient) who are or will be involved in activities under this award of both--

(1) this award requirement for verification of employment eligibility, and

(2) the associated provisions in 8 U.S.C. 1324a(a)(1) that, generally speaking, make it unlawful, in the United States, to hire (or recruit for employment) certain aliens.

C. Provide training (to the extent necessary) to those persons required by this condition to be notified of the award requirement for employment eligibility verification and of the associated provisions of 8 U.S.C. 1324a(a)(1).

D. As part of the recordkeeping for the award (including pursuant to the Part 200 Uniform Requirements), maintain records of all employment eligibility verifications pertinent to compliance with this award condition in accordance with Form I-9 record retention requirements, as well as records of all pertinent notifications and trainings.

2. Monitoring

The recipient's monitoring responsibilities include monitoring of subrecipient compliance with this condition.

3. Allowable costs

To the extent that such costs are not reimbursed under any other federal program, award funds may be obligated for the reasonable, necessary, and allocable costs (if any) of actions designed to ensure compliance with this condition.

4. Rules of construction

A. Staff involved in the hiring process

For purposes of this condition, persons "who are or will be involved in activities under this award" specifically includes (without limitation) any and all recipient (or any subrecipient) officials or other staff who are or will be involved in the hiring process with respect to a position that is or will be funded (in whole or in part) with award funds.

B. Employment eligibility confirmation with E-Verify

For purposes of satisfying the requirement of this condition regarding verification of employment eligibility, the recipient (or any subrecipient) may choose to participate in, and use, E-Verify (www.e-verify.gov), provided an appropriate person authorized to act on behalf of the recipient (or subrecipient) uses E-Verify (and follows the proper E-Verify procedures, including in the event of a "Tentative Nonconfirmation" or a "Final Nonconfirmation") to confirm employment eligibility for each hiring for a position in the United States that is or will be funded (in whole or in part) with award funds.

C. "United States" specifically includes the District of Columbia, Puerto Rico, Guam, the Virgin Islands of the United States, and the Commonwealth of the Northern Mariana Islands.

D. Nothing in this condition shall be understood to authorize or require any recipient, any subrecipient at any tier, or any person or other entity, to violate any federal law, including any applicable civil rights or nondiscrimination law.

E. Nothing in this condition, including in paragraph 4.B., shall be understood to relieve any recipient, any subrecipient at any tier, or any person or other entity, of any obligation otherwise imposed by law, including 8 U.S.C. 1324a(a)(1).

Questions about E-Verify should be directed to DHS. For more information about E-Verify visit the E-Verify website (<https://www.e-verify.gov/>) or email E-Verify at E-Verify@dhs.gov. E-Verify employer agents can email E-Verify at E-VerifyEmployerAgent@dhs.gov.

Questions about the meaning or scope of this condition should be directed to OJP, before award acceptance.

16

Encouragement of policies to ban text messaging while driving

Pursuant to Executive Order 13513, "Federal Leadership on Reducing Text Messaging While Driving," 74 Fed. Reg. 51225 (October 1, 2009), DOJ encourages recipients and subrecipients ("subgrantees") to adopt and enforce policies banning employees from text messaging while driving any vehicle during the course of performing work funded by this award, and to establish workplace safety policies and conduct education, awareness, and other outreach to decrease crashes caused by distracted drivers.

17

Reclassification of various statutory provisions to a new Title 34 of the United States Code

On September 1, 2017, various statutory provisions previously codified elsewhere in the U.S. Code were editorially reclassified (that is, moved and renumbered) to a new Title 34, entitled "Crime Control and Law Enforcement." The reclassification encompassed a number of statutory provisions pertinent to

OJP awards (that is, OJP grants and cooperative agreements), including many provisions previously codified in Title 42 of the U.S. Code.

Effective as of September 1, 2017, any reference in this award document to a statutory provision that has been reclassified to the new Title 34 of the U.S. Code is to be read as a reference to that statutory provision as reclassified to Title 34. This rule of construction specifically includes references set out in award conditions, references set out in material incorporated by reference through award conditions, and references set out in other award requirements.

18

Restrictions and certifications regarding non-disclosure agreements and related matters

No recipient or subrecipient ("subgrantee") under this award, or entity that receives a procurement contract or subcontract with any funds under this award, may require any employee or contractor to sign an internal confidentiality agreement or statement that prohibits or otherwise restricts, or purports to prohibit or restrict, the reporting (in accordance with law) of waste, fraud, or abuse to an investigative or law enforcement representative of a federal department or agency authorized to receive such information.

The foregoing is not intended, and shall not be understood by the agency making this award, to contravene requirements applicable to Standard Form 312 (which relates to classified information), Form 4414 (which relates to sensitive compartmented information), or any other form issued by a federal department or agency governing the nondisclosure of classified information.

1. In accepting this award, the recipient—

- a. represents that it neither requires nor has required internal confidentiality agreements or statements from employees or contractors that currently prohibit or otherwise currently restrict (or purport to prohibit or restrict) employees or contractors from reporting waste, fraud, or abuse as described above; and
- b. certifies that, if it learns or is notified that it is or has been requiring its employees or contractors to execute agreements or statements that prohibit or otherwise restrict (or purport to prohibit or restrict), reporting of waste, fraud, or abuse as described above, it will immediately stop any further obligations of award funds, will provide prompt written notification to the federal agency making this award, and will resume (or permit resumption of) such obligations only if expressly authorized to do so by that agency.

2. If the recipient does or is authorized under this award to make subawards ("subgrants"), procurement contracts, or both--

a. it represents that—

(1) it has determined that no other entity that the recipient's application proposes may or will receive award funds (whether through a subaward ("subgrant"), procurement contract, or subcontract under a procurement contract) either requires or has required internal confidentiality agreements or statements from employees or contractors that currently prohibit or otherwise currently restrict (or purport to prohibit or restrict) employees or contractors from reporting waste, fraud, or abuse as described above; and

(2) it has made appropriate inquiry, or otherwise has an adequate factual basis, to support this representation; and

b. it certifies that, if it learns or is notified that any subrecipient, contractor, or subcontractor entity that receives funds under this award is or has been requiring its employees or contractors to execute agreements or statements that prohibit or otherwise restrict (or purport to prohibit or restrict), reporting of waste, fraud, or abuse as described above, it will immediately stop any further obligations of award funds to or by that entity, will provide prompt written notification to the federal agency making this award, and will resume (or permit resumption of) such obligations only if expressly authorized to do so by that agency.

19**OJP Training Guiding Principles**

Any training or training materials that the recipient -- or any subrecipient ("subgrantee") at any tier -- develops or delivers with OJP award funds must adhere to the OJP Training Guiding Principles for Grantees and Subgrantees, available at <https://www.ojp.gov/funding/implement/training-guiding-principles-grantees-and-subgrantees>.

20

Specific post-award approval required to use a noncompetitive approach in any procurement contract that would exceed \$250,000

The recipient, and any subrecipient ("subgrantee") at any tier, must comply with all applicable requirements to obtain specific advance approval to use a noncompetitive approach in any procurement contract that would exceed the Simplified Acquisition Threshold (currently, \$250,000). This condition applies to agreements that -- for purposes of federal grants administrative requirements -- OJP considers a procurement "contract" (and therefore does not consider a subaward).

The details of the requirement for advance approval to use a noncompetitive approach in a procurement contract under an OJP award are posted on the OJP web site at <https://ojp.gov/funding/Explore/NoncompetitiveProcurement.htm> (Award condition: Specific post-award approval required to use a noncompetitive approach in a procurement contract (if contract would exceed \$250,000)), and are incorporated by reference here.

21**Requirement to report potentially duplicative funding**

If the recipient currently has other active awards of federal funds, or if the recipient receives any other award of federal funds during the period of performance for this award, the recipient promptly must determine whether funds from any of those other federal awards have been, are being, or are to be used (in whole or in part) for one or more of the identical cost items for which funds are provided under this award. If so, the recipient must promptly notify the DOJ awarding agency (OJP or OVW, as appropriate) in writing of the potential duplication, and, if so requested by the DOJ awarding agency, must seek a budget-modification or change-of-project-scope Grant Award Modification (GAM) to eliminate any inappropriate duplication of funding.

22**Required training for Grant Award Administrator and Financial Manager**

The Grant Award Administrator and all Financial Managers for this award must have successfully completed an "OJP financial management and grant administration training" by 120 days after the date of the recipient's acceptance of the award. Successful completion of such a training on or after January 1, 2021, will satisfy this condition.

In the event that either the Grant Award Administrator or a Financial Manager for this award changes during the period of performance, the new Grant Award Administrator or Financial Manager must have successfully completed an "OJP financial management and grant administration training" by 120 calendar days after the date the Entity Administrator enters updated Grant Award Administrator or Financial Manager information in JustGrants. Successful completion of such a training on or after January 1, 2021, will satisfy this condition.

A list of OJP trainings that OJP will consider "OJP financial management and grant administration training" for purposes of this condition is available at <https://onlinegmt.training.ojp.gov/>. All trainings that satisfy this condition include a session on grant fraud prevention and detection.

The recipient should anticipate that OJP will immediately withhold ("freeze") award funds if the recipient fails to comply with this condition. The recipient's failure to comply also may lead OJP to impose additional appropriate conditions on this award.

23

Compliance with 41 U.S.C. 4712 (including prohibitions on reprisal; notice to employees)

The recipient (and any subrecipient at any tier) must comply with, and is subject to, all applicable provisions of 41 U.S.C. 4712, including all applicable provisions that prohibit, under specified circumstances, discrimination against an employee as reprisal for the employee's disclosure of information related to gross mismanagement of a federal grant, a gross waste of federal funds, an abuse of authority relating to a federal grant, a substantial and specific danger to public health or safety, or a violation of law, rule, or regulation related to a federal grant.

The recipient also must inform its employees, in writing (and in the predominant native language of the workforce), of employee rights and remedies under 41 U.S.C. 4712.

Should a question arise as to the applicability of the provisions of 41 U.S.C. 4712 to this award, the recipient is to contact the DOJ awarding agency (OJP or OVW, as appropriate) for guidance.

24

Requirements pertaining to prohibited conduct related to trafficking in persons (including reporting requirements and OJP authority to terminate award)

The recipient, and any subrecipient ("subgrantee") at any tier, must comply with all applicable requirements (including requirements to report allegations) pertaining to prohibited conduct related to the trafficking of persons, whether on the part of recipients, subrecipients ("subgrantees"), or individuals defined (for purposes of this condition) as "employees" of the recipient or of any subrecipient. The details of the recipient's obligations related to prohibited conduct related to trafficking in persons are posted on the OJP web site at <https://ojp.gov/funding/Explore/ProhibitedConduct-Trafficking.htm> (Award condition: Prohibited conduct by recipients and subrecipients related to trafficking in persons (including reporting requirements and OJP authority to terminate award)), and are incorporated by reference here.

25

Potential imposition of additional requirements

The recipient agrees to comply with any additional requirements that may be imposed by the DOJ awarding agency (OJP or OVW, as appropriate) during the period of performance for this award, if the recipient is designated as "high-risk" for purposes of the DOJ high-risk grantee list.

26

Requirement to report actual or imminent breach of personally identifiable information (PII)

The recipient (and any "subrecipient" at any tier) must have written procedures in place to respond in the event of an actual or imminent "breach" (OMB M-17-12) if it (or a subrecipient) -- (1) creates, collects, uses, processes, stores, maintains, disseminates, discloses, or disposes of "Personally Identifiable Information (PII)" (2 CFR 200.1) within the scope of an OJP grant-funded program or activity, or (2) uses or operates a "Federal information system" (OMB Circular A-130). The recipient's breach procedures must include a requirement to report actual or imminent breach of PII to an OJP Program Manager no later than 24 hours after an occurrence of an actual breach, or the detection of an imminent breach.

27

Requirements related to System for Award Management and Universal Identifier Requirements

The recipient must comply with applicable requirements regarding the System for Award Management (SAM), currently accessible at <https://www.sam.gov/>. This includes applicable requirements regarding registration with SAM, as well as maintaining the currency of information in SAM.

The recipient also must comply with applicable restrictions on subawards ("subgrants") to first-tier subrecipients (first-tier "subgrantees"), including restrictions on subawards to entities that do not acquire and provide (to the recipient) the unique entity identifier required for SAM registration.

The details of the recipient's obligations related to SAM and to unique entity identifiers are posted on the OJP web site at <https://ojp.gov/funding/Explore/SAM.htm> (Award condition: System for Award Management (SAM) and Universal Identifier Requirements), and are incorporated by reference here.

This condition does not apply to an award to an individual who received the award as a natural person (i.e., unrelated to any business or non-profit organization that he or she may own or operate in his or her name).

28

Compliance with restrictions on the use of federal funds--prohibited and controlled equipment under OJP awards

Consistent with Executive Order 14074, "Advancing Effective, Accountable Policing and Criminal Justice Practices To Enhance Public Trust and Public Safety," OJP has prohibited the use of federal funds under this award for purchases or transfers of specified equipment by law enforcement agencies. In addition, OJP requires the recipient, and any subrecipient ("subgrantee") at any tier, to put in place specified controls prior to using federal funds under this award to acquire or transfer any property identified on the "controlled equipment" list. The details of the requirement are posted on the OJP web site at <https://www.ojp.gov/funding/explore/prohibited-and-controlled-equipment> (Award condition: Compliance with restrictions on the use of federal funds--prohibited and controlled equipment under OJP awards), and are incorporated by reference here.

29

Restrictions on "lobbying"

In general, as a matter of federal law, federal funds awarded by OJP may not be used by the recipient, or any subrecipient ("subgrantee") at any tier, either directly or indirectly, to support or oppose the enactment, repeal, modification, or adoption of any law, regulation, or policy, at any level of government. See 18 U.S.C. 1913. (There may be exceptions if an applicable federal statute specifically authorizes certain activities that otherwise would be barred by law.)

Another federal law generally prohibits federal funds awarded by OJP from being used by the recipient, or any subrecipient at any tier, to pay any person to influence (or attempt to influence) a federal agency, a Member of Congress, or Congress (or an official or employee of any of them) with respect to the awarding of a federal grant or cooperative agreement, subgrant, contract, subcontract, or loan, or with respect to actions such as renewing, extending, or modifying any such award. See 31 U.S.C. 1352. Certain exceptions to this law apply, including an exception that applies to Indian tribes and tribal organizations.

Should any question arise as to whether a particular use of federal funds by a recipient (or subrecipient) would or might fall within the scope of these prohibitions, the recipient is to contact OJP for guidance, and may not proceed without the express prior written approval of OJP.

30

All subawards ("subgrants") must have specific federal authorization

The recipient, and any subrecipient ("subgrantee") at any tier, must comply with all applicable

requirements for authorization of any subaward. This condition applies to agreements that -- for purposes of federal grants administrative requirements -- OJP considers a "subaward" (and therefore does not consider a procurement "contract").

The details of the requirement for authorization of any subaward are posted on the OJP web site at <https://ojp.gov/funding/Explore/SubawardAuthorization.htm> (Award condition: All subawards ("subgrants") must have specific federal authorization), and are incorporated by reference here.

31

Compliance with DOJ regulations pertaining to civil rights and nondiscrimination - 28 C.F.R. Part 54

The recipient, and any subrecipient ("subgrantee") at any tier, must comply with all applicable requirements of 28 C.F.R. Part 54, which relates to nondiscrimination on the basis of sex in certain "education programs."

Among other items, 28 C.F.R. § 54.140 contains notice requirements that covered recipients must follow regarding the dissemination of information regarding federal nondiscrimination requirements.

32

FFATA reporting: Subawards and executive compensation

The recipient must comply with applicable requirements to report first-tier subawards ("subgrants") of \$30,000 or more and, in certain circumstances, to report the names and total compensation of the five most highly compensated executives of the recipient and first-tier subrecipients (first-tier "subgrantees") of award funds. The details of recipient obligations, which derive from the Federal Funding Accountability and Transparency Act of 2006 (FFATA), are posted on the OJP web site at <https://ojp.gov/funding/Explore/FFATA.htm> (Award condition: Reporting Subawards and Executive Compensation), and are incorporated by reference here.

This condition, including its reporting requirement, does not apply to-- (1) an award of less than \$30,000, or (2) an award made to an individual who received the award as a natural person (i.e., unrelated to any business or non-profit organization that he or she may own or operate in his or her name).

33

The recipient agrees to submit a final report at the end of this award documenting all relevant project activities during the entire period of support under this award. This report will include detailed information about the project(s) funded, including, but not limited to, information about how the funds were actually used for each purpose area, data to support statements of progress, and data concerning individual results and outcomes of funded projects reflecting project successes and impacts. The final report is due no later than 120 days following the close of this award period or the expiration of any extension periods. This report will be submitted to the Office of Justice Programs, on-line through the Internet at <https://justgrants.usdoj.gov/>

34

Title II Performance Reports

The recipient shall submit annual performance reports. Performance reports shall be submitted after the end of the reporting period (October 1 - September 30), no later than December 30 of each year, for the life of the award. These reports will be submitted to the Office of Justice Programs, on-line through the Internet at [https://justgrants.usdoj.gov.](https://justgrants.usdoj.gov/)

35

Justification of consultant rate

Approval of this award does not indicate approval of any consultant rate in excess of \$650 per day. A

detailed justification must be submitted to and approved by the OJP program office prior to obligation or expenditure of such funds.

36

OJJDP- Title II - Withholding of funds for pending budget documentation

The recipient may not expend or draw down award funds until the recipient submits, and OJP reviews and approves, the required budget and budget narrative reflecting the total amount for the award, and an Award Condition Modification (ACM) has been issued to remove this award condition.

37

The grantee agrees that not later than 60 days after the date on which the award is made (or, if applicable, 60 days after OJJDP releases a grant condition requiring a revised state plan), the grantee shall make the state plan or amended plan required under 34 U.S.C. 11133(a), and submitted as part of the application for this award, publicly available, by posting it on the state's publicly available website.

38

The recipient agrees that, consistent with applicable State law, staff directly associated with administration of the OJJDP Formula Grants Program will attend and participate in conferences, workshops, training sessions and other national or regional meetings deemed by OJJDP to be critical to the administration of this Program. OJJDP will determine which staff and the number of staff that should attend each meeting, consistent with the scope and subject matter of the meeting. Cost of attendance will be borne by the recipient as an administrative cost to the grant or paid from State Advisory Group set aside funds under Section 222(d), as appropriate.

39

The recipient agrees that, as required by federal law (31 U.S.C. 1301(a)), the funds allocated to support its State Advisory Group (SAG) pursuant to 34 U.S.C. 11132(d) must be expended in a manner consistent with the purposes set forth at 34 U.S.C. 11133(a)(3)(B), (C), and (D). If the recipient's SAG chooses to use a portion of its limited formula grant set-aside for organizational membership fees, such costs are only allowable if those costs meet the requirements of 2 C.F.R. 200.454. The use of federal funds for 1) cash or in-kind contributions, 2) donations, or 3) payment of membership fees in organizations substantially engaged in lobbying, is specifically prohibited by 2 C.F.R. 434 and 454.

40

Pursuant to Section 223(a)(3)(A)(iii) of the Juvenile Justice and Delinquency Prevention Act of 1974, as amended (34 U.S.C. 11101, et seq.), the chairperson of the State Advisory Group cannot be a full-time employee of the Federal, State, or local government. This prohibition applies also to an Acting Chair, or other person assuming the duties and responsibilities of the Chair, whether permanently or on a temporary basis.

41

"Methods of Administration" - monitoring compliance with civil rights laws and nondiscrimination provisions

The recipient's monitoring responsibilities include monitoring of subrecipient compliance with applicable federal civil rights laws and nondiscrimination provisions. Within 90 days of the date of award acceptance, the recipient must submit to OJP's Office for Civil Rights (at CivilRightsMOA@usdoj.gov) written Methods of Administration ("MOA") for subrecipient monitoring with respect to civil rights requirements. In addition, upon request by OJP (or by another authorized federal agency), the recipient must make associated documentation available for review.

The details of the recipient's obligations related to Methods of Administration are posted on the OJP web site at <https://ojp.gov/funding/Explore/StateMethodsAdmin-FY2017update.htm> (Award condition: "Methods of Administration" - Requirements applicable to States (FY 2017 Update)), and are incorporated by reference here.

42

Confidentiality of data

The recipient (and any subrecipient at any tier) must comply with all confidentiality requirements of 34 U.S.C. 10231 and 28 C.F.R. Part 22 that are applicable to collection, use, and revelation of data or information. The recipient further agrees, as a condition of award approval, to submit a Privacy Certificate that is in accord with requirements of 28 C.F.R. Part 22 and, in particular, 28 C.F.R. 22.23.

43

Protection of human research subjects

The recipient (and any subrecipient at any tier) must comply with the requirements of 28 C.F.R. Part 46 and all OJP policies and procedures regarding the protection of human research subjects, including obtainment of Institutional Review Board approval, if appropriate, and subject informed consent.

44

Recipient integrity and performance matters: Requirement to report information on certain civil, criminal, and administrative proceedings to SAM and FAPIIS

The recipient must comply with any and all applicable requirements regarding reporting of information on civil, criminal, and administrative proceedings connected with (or connected to the performance of) either this OJP award or any other grant, cooperative agreement, or procurement contract from the federal government. Under certain circumstances, recipients of OJP awards are required to report information about such proceedings, through the federal System for Award Management (known as "SAM"), to the designated federal integrity and performance system (currently, "FAPIIS").

The details of recipient obligations regarding the required reporting (and updating) of information on certain civil, criminal, and administrative proceedings to the federal designated integrity and performance system (currently, "FAPIIS") within SAM are posted on the OJP web site at <https://ojp.gov/funding/FAPIIS.htm> (Award condition: Recipient Integrity and Performance Matters, including Recipient Reporting to FAPIIS), and are incorporated by reference here.



APPLICATION FOR A LOCAL PERMIT OR RESTRICTED EVENT PERMIT
 NORTH DAKOTA OFFICE OF ATTORNEY GENERAL
 GAMING DIVISION
 SFN 9338 (8-2025)

Applying for (check one)

Local Permit Restricted Event Permit*

Games to be conducted Raffle by a Political or Legislative District Party

Bingo Raffle Raffle Board Calendar Raffle Sports Pool Poker* Twenty-One* Paddlewheels*

*See Instruction 2 (f) on Page 2. Poker, Twenty-One, and Paddlewheels may be conducted Only with a Restricted Event Permit. Only one permit per year.
LOCAL PERMIT RAFFLES MAY NOT BE CONDUCTED ONLINE AND CREDIT CARDS MAY NOT BE USED FOR WAGERS

ORGANIZATION INFO

Name of Organization or Group St. John Paul II Catholic Schools		Dates of Activity (Does not include dates for the sales of tickets) January 17-25, 2026	
Organization or Group Contact Person Liz Bassett	E-mail liz.bassett@jp2schools.org	Telephone Number 301-893-3242	
Business Address 5600 25th Street S	City Fargo	State ND	ZIP Code 58104
Mailing Address (if different)	City	State	ZIP Code

SITE INFO

Site Name Trinity Elementary School	County CASS
Site Physical Address 2711 7th Street E	City West Fargo
	State ND
	ZIP Code 58078

Provide the exact date(s) & frequency of each event & type (Ex. Bingo every Friday 10/1-12/31, Raffle - 10/30, 11/30, 12/31, etc.)

PRIZE / AWARD INFO (if More Prizes, Attach An Additional Sheet)

Game Type	Description of Prize	Exact Retail Value of Prize
Raffle Board	3-night stay in Deadwood, SD	\$1,500
Total (limit \$50,000 per year)		\$

ADDITIONAL REQUIRED INFORMATION

Intended Uses of Gaming Proceeds
Support needs of Trinity Elementary School

Does the organization presently have a state gaming license? (If yes, the organization is not eligible for a local permit or restricted event permit and should call the Office of Attorney General at 1-800-326-9240)

Yes No

Has the organization or group received a restricted event permit from any city or county for the fiscal year July 1 - June 30 (If yes, the organization or group does not qualify for a local permit or restricted event permit)

Yes No

Has the organization or group received a local permit from an city or county for the fiscal year July 1 - June 30 (If yes, indicate the total retail value of all prizes previously awarded)

No Yes - Total Retail Value: **\$7,757.50** (This amount is part of the total prize limit for \$50,000 per fiscal year)

Is the organization or group a state political party or legislative district party? (If yes, the organization or group may only conduct a raffle and must complete SFN 52880 "Report on a Restricted Event Permit" within 30 days of the event. Net proceeds may be for political purposes.)

Yes No

Printed Name of Organization Group's Permit Organizer Liz Bassett	Telephone Number 701-893-3242	E-mail Address liz.bassett@jp2schools.org
Signature of Organization Group's Permit Organizer 	Title Special Events Coordinator	Date 12/1/2025



APPLICATION FOR A LOCAL PERMIT OR RESTRICTED EVENT PERMIT
 NORTH DAKOTA OFFICE OF ATTORNEY GENERAL
 GAMING DIVISION
 SFN 9338 (8-2025)

Applying for (check one)

Local Permit Restricted Event Permit*

Games to be conducted

Bingo Raffle Raffle Board Calendar Raffle Sports Pool Poker* Twenty-One* Paddlewheels*

*See Instruction 2 (f) on Page 2. Poker, Twenty-One, and Paddlewheels may be conducted Only with a Restricted Event Permit. Only one permit per year.
LOCAL PERMIT RAFFLES MAY NOT BE CONDUCTED ONLINE AND CREDIT CARDS MAY NOT BE USED FOR WAGERS

ORGANIZATION INFO

Name of Organization or Group VOLT Volleyball		Dates of Activity (Does not include dates for the sales of tickets) February 1-28, 2026	
Organization or Group Contact Person Kristen Peterson	E-mail kandjpeterson@msn.com	Telephone Number 701-630-1635	
Business Address PO Box 208	City West Fargo	State ND	ZIP Code 58078
Mailing Address (if different)	City	State	ZIP Code

SITE INFO

Site Name VOLT Volleyball	County Cass		
Site Physical Address 1927 Queensbury Street	City West Fargo	State ND	ZIP Code 58078
Provide the exact date(s) & frequency of each event & type (Ex. Bingo every Friday 10/1-12/31, Raffle - 10/30, 11/30, 12/31, etc.) Calendar raffle every day February 1-28, 2026			

PRIZE / AWARD INFO (If More Prizes, Attach An Additional Sheet)

Game Type	Description of Prize	Exact Retail Value of Prize
Raffle	Cash prize varies per daily drawing	10,000.00
Total (limit \$50,000 per year)		\$

ADDITIONAL REQUIRED INFORMATION

Intended Uses of Gaming Proceeds
Fundraiser to support operating costs of athletic club

Does the organization presently have a state gaming license? (If yes, the organization is not eligible for a local permit or restricted event permit and should call the Office of Attorney General at 1-800-326-9240)
 Yes No

Has the organization or group received a restricted event permit from any city or county for the fiscal year July 1 - June 30 (If yes, the organization or group does not qualify for a local permit or restricted event permit)
 Yes No

Has the organization or group received a local permit from an city or county for the fiscal year July 1 - June 30 (If yes, indicate the total retail value of all prizes previously awarded)
 No Yes - Total Retail Value: (This amount is part of the total prize limit for \$50,000 per fiscal year)

Is the organization or group a state political party or legislative district party? (If yes, the organization or group may only conduct a raffle and must complete SFN 52880 "Report on a Restricted Event Permit" within 30 days of the event. Net proceeds may be for political purposes.)
 Yes No

Printed Name of Organization Group's Permit Organizer Kristen M Peterson	Telephone Number 701-630-1635	E-mail Address kandjpeterson@msn.com
Signature of Organization Group's Permit Organizer 	Title Board President	Date 12/03/2025



“Consent” or “Regular” Agenda Item?

[Regular]

To: West Fargo City Commission

From: Jerry Wallace, City Engineer

Date: December 15, 2025

Subject: Floodplain Management Ordinance Amendment

Action: Approve 1st Reading of Amended Floodplain Management Ordinance

Commission President

Bernie Dardis
Primary Portfolio:
Administrative Services
Secondary Portfolio:
Police & Fire

Commission Vice President

Brad Olson
Primary Portfolio:
Police & Fire
Secondary Portfolio:
Street, Water & Sewer

Commissioner

Roben Anderson
Primary Portfolio:
Community & Development Services
Secondary Portfolio:
Administrative Services

Commissioner

Rory Jorgensen
Primary Portfolio:
Sanitation
Secondary Portfolio:
Community & Development Services

Commissioner

Amy Zundel
Primary Portfolio:
Street, Water & Sewer
Secondary Portfolio:
Sanitation

City Administrator

Dustin T. Scott

New Information and Recommendation:

The City of West Fargo participates in the National Flood Insurance Program (NFIP) and maintains a Floodplain Management Ordinance consistent with state and federal requirements. The current ordinance was adopted on September 5, 2025, following updates to align with FEMA standards and recent floodplain map revisions.

On August 1, 2025, North Dakota Senate Bill 2027 took effect, updating several provisions of state law related to floodplain management, primarily N.D.C.C. Chapter 61-16.2, as well as Chapters 11-11, 40-05, 40-47, and 58-06. The legislation clarifies the regulatory authority of counties, cities, and townships and establishes a statewide central repository for all local floodplain management ordinances, administered by the North Dakota Department of Water Resources (ND DWR).

The following documents are attached for review/consideration:

- Ordinance No. 1267 – An amendment to the City of West Fargo Floodplain Management Ordinance.

Staff Recommendation: Approve 1st Reading of Amended Floodplain Management Ordinance

Background and Summary:

Senate Bill 2027 requires local jurisdictions to update Floodplain Management Ordinances, including revisions to referenced Century Code chapters. The legislation also requires the City of West Fargo to submit an annual recertification affirming its intent to continue regulating development within Special Flood Hazard Areas (SFHAs) and to provide ND DWR with a copy of its approved ordinance. City staff are coordinating with ND DWR to ensure compliance.

Policy Analysis:

The City encourages property owners to locate new development outside designated Special Flood Hazard Areas. When development within an SFHA is necessary, the City works to ensure it is completed safely, cost-effectively, and in full compliance with NFIP requirements.

Financial Analysis:

Not applicable.

Previously Presented Information and Commission Actions:

August 18, 2025 –

- **Staff Recommendation:** Adopt the City's updated Floodplain Management Ordinance
- **Commission Action:** Commissioner Olson moved and Commissioner Zundel seconded to approve. Commissioner Anderson was absent and not voting. No opposition, motion carried.

August 4, 2025 –

- **Staff Recommendation:** First Reading – Approve the first reading regarding the Adoption of the City's updated Floodplain Management Ordinance.
- **Commission Action:** Public hearing was held. No comments for or against were received. Commissioner Zundel moved and Commissioner Anderson seconded to approve the first reading. No opposition, motion carried.

ORDINANCE NO. 1267

AN ORDINANCE TO AMEND AND REENACT SECTION 5-0401 OF THE REVISED ORDINANCES OF 1990 OF THE CITY OF WEST FARGO RELATING TO FLOODPLAIN MANAGEMENT STATUTORY AUTHORIZATION.

BE IT ORDAINED BY THE BOARD OF CITY COMMISSIONERS OF THE CITY OF WEST FARGO, NORTH DAKOTA:

SECTION 1. Section 5-0401 of the Revised Ordinances of 1990 of the City of West Fargo, North Dakota is hereby amended and reenacted to read as follows:

5-0401. STATUTORY AUTHORIZATION. The Legislature of the State of North Dakota has in Chapters 40-4705, 11-11 and 58-06 of the North Dakota Century Code delegated the responsibility to local governmental units to adopt regulations designed to promote the public health, safety, and general welfare of its citizenry. Therefore, the Board of City Commissioners of the City of West Fargo, North Dakota does ordain as follows:

SECTION 2. Effective Date. This ordinance shall be in full force and effect from and after the date of its second reading and final passage.

President of Board of City Commissioners
of the City of West Fargo, North Dakota

ATTEST:

City Auditor

Date of First Reading: **12/15/2025**

Date of Second Reading:

Date of Publication:



<input type="checkbox"/> Consent Agenda
<input checked="" type="checkbox"/> Regular Agenda

Item Title: Ordinance No. 1266 – Municipal Judge

Presented By: Dustin Scott, City Administrator

Requested Action: Public Hearing and Consideration of the First Reading

Summary:

City staff, in coordination with the City Attorney, prepared this draft ordinance relating to the Municipal Judge. The ordinance updates and reorganizes the City's municipal judge provisions to ensure alignment with state law and modern practices. It clarifies residency requirements for the elected Municipal Judge while allowing the Commission flexibility to appoint qualified non-resident alternates when needed. It also updates judicial duties, reporting requirements, and court convening provisions.

ORDINANCE NO. 1266

AN ORDINANCE TO CREATE AND ENACT CHAPTER 1-12 OF THE REVISED ORDINANCES OF 1990 OF THE CITY OF WEST FARGO RELATING TO THE MUNICIPAL JUDGE, AND TO AMEND AND REENACT SECTION 1-0802 RELATING TO THE PLACE MUNICIPAL COURT IS CONVENED.

BE IT ORDAINED BY THE BOARD OF CITY COMMISSIONERS OF THE CITY OF WEST FARGO, NORTH DAKOTA:

SECTION 1. Chapter 1-12 of the Revised Ordinances of 1990 of the City of West Fargo, North Dakota, is hereby created and enacted to read as follows:

CHAPTER 1-12
MUNICIPAL JUDGE

SECTIONS:

- 1-1201. Election and Term of Office.
- 1-1202. Duties and Powers.
- 1-1203. Qualification of Municipal Judge.
- 1-1204. Compensation.
- 1-1205. Report to City Administrator.
- 1-1206. Conduct and Decorum.
- 1-1207. Alternate Municipal Judge.
- 1-1208. Supreme Court Rule Compliance.

1-1201. ELECTION AND TERM OF OFFICE. The office of the Municipal Judge shall be an elected position, and the Municipal Judge shall be elected in the same manner as other elected City officials are elected to office. The Municipal Judge shall hold office for a term of four (4) years from and after the election and until a successor is elected and qualified. The Municipal Judge position may be a part-time position.

1-1202. DUTIES AND POWERS. The Municipal Judge has the power to perform all duties prescribed by state law and the ordinances of the City. The Municipal Judge shall hear, try, and determine all offenses against the ordinances adopted by the Board of City Commissioners and has the authority to impose any fee, fine, court cost, impact fee, or other charge authorized by state law or by a fee schedule approved by the Board of City Commissioners, or imposed by ordinances of the City.

1-1203. QUALIFICATIONS OF MUNICIPAL JUDGE. The Municipal Judge shall have the following qualifications:

1. The Municipal Judge shall not hold any other office in the City.
2. The Municipal Judge must be licensed to practice law in the State of North Dakota.
3. The Municipal Judge's primary place of residence must be within City limits; provided, however, an individual who is elected as the Municipal Judge shall have sixty (60) calendar days following the date of the election to establish the City as the primary place of residence. For purposes of this ordinance, the primary place of residence is established when an individual maintains a residence in the City and spends more than two hundred ten (210) overnights during a calendar year at the residence. A Municipal Judge shall notify the City Administrator in the event of a change in primary place of residence no later than seven (7) calendar days following the change.
4. The Municipal Judge shall not serve as a judge or justice of a court that oversees transfers or appeals from the municipal court.
5. If an individual fails to meet any of the qualifications set forth in this section, then the Board of City Commissioners may declare a vacancy in the Municipal Judge office and appoint an Alternate Municipal Judge as described in Section 1-1207.

1-1204. COMPENSATION. The Municipal Judge shall receive an annual salary set by the Board of City Commissioners as full compensation.

1-1205. REPORT TO CITY ADMINISTRATOR. It shall be the duty of the Municipal Judge to make a full report under oath of all proceedings in actions or matters in which the City is a party or interested therein to the City Administrator at the close of each month. Such report shall contain a statement of the amount of all costs and fines paid and the disposition thereof, together with an itemized account of the fees of the Municipal Judge and of all officers and witnesses and the names of each. This report shall be accompanied by the duplicate receipt of the Clerk of Court for the amount of the fees and money so collected on behalf of the City. If any Municipal Judge shall neglect or refuse to make such report or to pay over the money collected on behalf of the City or shall refuse to allow the Board of City Commissioners or any of its committees to examine the records of said Municipal Judge in regard to such matters, the salary of said Municipal Judge shall not be paid until such Municipal Judge has complied with the provisions of this ordinance.

1-1206. CONDUCT AND DECORUM. During all causes, proceedings, and trials held in the municipal court, it shall be the duty of the Municipal Judge to preserve order and dignity and to hear each matter with courtesy to all parties concerned.

1-1207. ALTERNATE MUNICIPAL JUDGE.

1. In the event that the Municipal Judge is unable to serve due to temporary absence, interest, disqualification based on something other than the qualifications set forth in Section 1-1203, or disability, the City shall appoint an Alternate Municipal Judge to serve in place of the Municipal Judge. As used in this subsection, temporary shall mean fifteen (15) calendar days or less. The Alternate Municipal Judge shall be compensated

on a per diem basis at the rate set by the Board of City Commissioners and shall possess the qualifications of a Municipal Judge set forth in Section 1-1203; provided, however, the Board of City Commissioners may waive the residency qualification as is necessary to fill the position.

2. Additionally, if a vacancy exists in the office of Municipal Judge by death, resignation, or otherwise, the Board of City Commissioners shall appoint an Alternate Municipal Judge to fill the vacancy. Such appointee shall possess the qualifications of a Municipal Judge set forth in Section 1-1203; provided, however, the Board of City Commissioners may waive the residency qualification as is necessary to fill the position. The Alternate Municipal Judge shall hold office until the next election and until a successor is elected and qualified.

1-1208. SUPREME COURT RULE COMPLIANCE. The Municipal Judge and any Alternate Municipal Judge shall comply with all rules, including the North Dakota Code of Judicial Conduct, and continuing judicial education requirements established by the North Dakota Supreme Court. The Municipal Judge and any Alternate Municipal Judge shall be reimbursed for necessary expenses of travel and subsistence as other City officials are so reimbursed.

SECTION 2. Section 1-0802 of the Revised Ordinances of 1990 of the City of West Fargo, North Dakota, is hereby amended and reenacted by amending the place the municipal court of West Fargo is convened to read as follows:

PLACE CONVENED. The municipal court of West Fargo shall convene ~~and at the City Hall, City of West Fargo, State of North Dakota~~ at a location within the City of West Fargo, State of North Dakota, as designated by the Municipal Judge. The municipal court shall convene no less than three (3) times per calendar month.

SECTION 3. Effective Date. This ordinance shall be in full force and effect from and after the date of its second reading and final passage.

President of Board of City Commissioners
of the City of West Fargo, North Dakota

ATTEST:

City Auditor

Date of First Reading:

Date of Second Reading
And Final Passage:

DRAFT

Item Title: Contract with City of Fargo (MATBUS) for 2026 transit service, request for contract approval

Presented By: Aaron Nelson, Planning Director

Requested Action/Staff Recommendation: Approve 2026 Transit Contract

Background & Project Summary:

The City of Fargo has provided contract transit service to the City of West Fargo for many years. An annual Mass Transit Agreement, approved by each city, outlines the transit service to be provided as well as the cost of the service. Costs and revenues are apportioned to the City of West Fargo based on a funding formula that accounts for the share of transit service provided within West Fargo's corporate limits, which includes portions of two fixed bus routes and paratransit services within the City. The City's current annual Mass Transit Agreement expires at the end of 2025 and will need to be renewed for 2026. At this time, there are no proposed changes to existing transit services or routes. The requested action is to renew the City's annual contract for transit services.

The agreement for these services for 2026 is attached for consideration.

Attached Supporting Documents:

- 2026 Mass Transit Agreement

Financial Impact:

Total transit costs for 2026 are estimated to be \$451,430, based on anticipated ridership levels in West Fargo throughout the 2026 calendar year. Transit services will be invoiced monthly, based on actual ridership. As such, actual costs will vary from this estimate. Transit costs have been budgeted within the 2026 City budget.

Policy Alignment:

No changes in relation to existing policy. Transit services will remain the same as in recent years.

Process/Timeline:

The attached agreement will need to be executed by the Cities of Fargo and West Fargo. With the approved agreement, existing transit services will continue through 2026.

West Fargo City Commission

Bernie Dardis, Commission President
Brad Olson, Commission Vice President
Roben Anderson, Rory Jorgensen, Amy Zundel, Commissioners
Dustin Scott, City Administrator

MASS TRANSIT AGREEMENT

This AGREEMENT made and entered into this 1st day of January, 2026, by and between the City of West Fargo, North Dakota (hereinafter "West Fargo") and the City of Fargo, North Dakota (hereinafter "Fargo").

WHEREAS, Fargo provides regular transit service and Paratransit service for its citizens; and

WHEREAS, West Fargo would like to provide such services to the citizens of West Fargo; and

WHEREAS, Fargo is agreeable to provide such transit service to West Fargo on the terms and conditions set out below;

NOW THEREFORE, be it agreed between West Fargo and Fargo as follows:

1. Fargo will provide regular transit service to West Fargo during the term of this agreement under the following conditions:
 - A. Fargo and West Fargo shall agree to routes, schedules, and stopping points of the transit service in West Fargo. It is understood that such West Fargo routes will tie into the Fargo route system at a designated transfer point(s). Route 20 and stopping points must be such that the route can be completed in approximately 60 minutes; the route will run once each hour. Route 24 and stopping points must be such that the route can be completed in approximately 60 minutes; the route will run once each hour.
 - B. Persons who get onto the bus in West Fargo shall not be charged a fee to transfer onto other bus routes of the bus system, and may transfer onto another bus with no transfer fee.
 - C. The bus fare for using the buses in West Fargo shall be the same fare that is charged to passengers using the bus service in Fargo.
 - D. Fargo shall be responsible for all administrative responsibilities regarding the bus transit service provided to West Fargo, including dispatching, complaint issues, annual grant applications, marketing of routes, preparation and revision of route maps and schedules, and filing of any necessary reports.
2. Fargo shall provide West Fargo transit service for persons with disabilities through the Paratransit service on the following conditions:
 - A. The service shall be available to the citizens of West Fargo on the same basis that it is available to citizens in Fargo.
 - B. The cost of the service to the citizens of West Fargo shall be the same cost as available to the citizens of Fargo.

- C. West Fargo, by written notification to Fargo, may limit the hours of Paratransit service in West Fargo, provided that such limitation would not cause any violation of any state or federal law.
3. West Fargo shall pay Fargo an estimated amount of \$451,430.72 over the term of this Agreement. Fargo shall bill, on a monthly basis, in accordance with the proposed Cost Share Allocation (**Attachment 1**) which provides for West Fargo to be responsible for fixed route and Paratransit services by total ridership, revenue hours and revenue miles by proportion to cumulative MATBUS service provided, with payment being due by the 10th day of each month.
 4. West Fargo shall adhere to the Emergency Service Guidelines that Fargo has implemented.
 5. This agreement shall be for a period of twelve (12) months, beginning on January 1, 2026 and terminating on December 31, 2026.
 6. Either party may terminate or reduce the amount of service to be rendered if there is, in the opinion of either party's City Commission, a significant increase in local costs; or, in the opinion of either party's City Commission, insufficient state or federal funding available for the service, thereby terminating this agreement or reducing the service and compensation to be paid under this agreement. In such event the terminating party will notify the other party in writing one hundred eighty (180) days in advance of the date such actions are to be implemented. In the event of any termination, West Fargo shall pay the agreed rate only for services delivered up to the date of termination. West Fargo has no obligation to Fargo, of any kind, after the date of termination.
 7. This agreement shall not be amended, except in writing executed by both parties.
 8. Nothing in this agreement shall be deemed a waiver by West Fargo or Fargo of the limits of liability set forth in N.D.C.C. § 32-12.1-03 or a waiver of any available immunities or defenses. Additionally, the limitations on liability for West Fargo and Fargo shall not be added together or stacked to increase the maximum amount of liability.
 9. West Fargo and Fargo are each responsible for securing liability insurance that it believes, in its discretion, will be adequate for this agreement. Additionally, West Fargo and Fargo are each responsible for securing workers' compensation insurance and employer's liability insurance at levels required under state law, or within its discretion, to cover any of its respective employees working under this agreement.
 10. Both parties agree to indemnify, save, and hold harmless the other and its agents and employees from any and all liability, loss, cost, damages, expenses, claims, or causes of action, including attorney's fees, arising out of or by reason of actions of the other or its agents or employees in connection with or in the execution, performance, or failure to adequately perform obligations pursuant to this agreement. The indemnification and hold harmless obligations set forth in this agreement shall survive the termination of this Agreement.

11. The parties will cooperate and use their best efforts to ensure that the various provisions of this agreement are fulfilled. The parties agree to act in good faith to undertake resolution of disputes in an equitable and timely manner and in accordance with the provisions of this agreement.
12. The District Court of Cass County, North Dakota, will be the sole and exclusive venue for any lawsuit pertaining to this agreement, and the Parties consent to the personal jurisdiction in said court in the event of any such lawsuit.
13. This agreement shall not be assigned without the express written consent of the other party.
14. Each provision, section, sentence, clause, phrase, and word of this agreement is intended to be severable. If any provision, section, sentence, clause, phrase, or word hereof is held by a court with jurisdiction to be illegal or invalid whatsoever, such illegality or invalidity will not affect the validity of the remainder of this agreement.
15. No party will be liable to another party during any period in which its performance is delayed or prevented, in whole or in part, by circumstances beyond its reasonable control. Circumstances include, but are not limited to, the following: act of God (e.g., flood, earthquake, wind), fire, war, act of a public enemy or terrorist, act of sabotage, strike or other labor dispute, riot, misadventure of the sea, inability to secure materials, or a restriction imposed by legislation, an order or a rule, or regulation of a governmental entity. If such a circumstance occurs, the party claiming the delay must undertake reasonable action to notify the other party of the same.
16. All notices, certificates, or other communications required under this agreement will be deemed sufficiently given when delivered or deposited in the United States mail in certified form with postage fully prepaid and addressed as follows:

If to West Fargo:	City Administrator City of West Fargo 2515 6 th Street East West Fargo, ND 58078
-------------------	--

If to Fargo:	City Administrator City of Fargo 225 4 th Street North Fargo, ND 58102
--------------	--

17. This agreement will be controlled by the laws of the State of North Dakota.
18. This agreement may be executed in counterparts, each of which shall be an original and all of which shall constitute but one and the same instrument. All parties will receive a fully-executed counterpart. The facsimile, email, or other electronically delivered

signatures of the parties will be deemed to constitute original signatures, and facsimile or electronic copies hereof will be deemed to constitute duplicable originals.

19. This agreement constitutes the entire agreement by and between the parties, and any other prior representations or agreements are deemed merged herein, and those not specified herein do not represent any agreements or promises or covenants or representations on the part of either party hereto.

IN WITNESS WHEREOF, the parties have caused this Mass Transit Agreement to be executed on the day and year first above written.

CITY OF WEST FARGO

BY: _____
Bernie L. Dardis, President, City Commission

ATTEST: _____
City Auditor

CITY OF FARGO

BY: _____
Timothy J. Mahoney, M.D., Mayor

ATTEST: _____
City Auditor

Expense			Fargo						Moorhead & Dilworth				West Fargo				NDSU				System Total	
Account Description	Account Total	Cost Spilt	Fixed Route		Paratransit		Microtransit		Fixed Route		Paratransit		Fixed Route		Paratransit		Fixed Route		Microtransit		Percent	Amount
			Percent	Amount	Percent	Amount	Percent	Amount	Percent	Amount	Percent	Amount	Percent	Amount	Percent	Amount	Percent	Amount	Percent	Amount	Percent	Amount
Admin																						
Full Time Staff	1,364,808.00	Revenue Hours	43.41%	592,452.35	14.71%	200,788.82	0.00%	-	26.21%	357,659.40	4.16%	56,767.97	1.92%	26,244.20	3.78%	51,621.71	5.37%	73,289.04	0.44%	5,984.51	100.00%	1,364,808.00
Temporary/Seasonal	8,715.00	Revenue Hours	43.41%	3,783.11	14.71%	1,282.14	-	-	26.21%	2,283.84	4.16%	362.49	1.92%	167.58	3.78%	329.63	5.37%	467.99	0.44%	38.21	100.00%	8,715.00
Health Insurance	288,558.00	Revenue Hours	43.41%	125,260.74	14.71%	42,452.29	0.00%	-	26.21%	75,619.05	4.16%	12,002.31	1.92%	5,548.75	3.78%	10,914.25	5.37%	15,495.32	0.44%	1,265.29	100.00%	288,558.00
Dental Insurance	10,537.00	Revenue Hours	43.41%	4,574.03	14.71%	1,550.19	0.00%	-	26.21%	2,761.31	4.16%	438.28	1.92%	202.62	3.78%	398.55	5.37%	565.83	0.44%	46.20	100.00%	10,537.00
Long Term Disability	1,838.00	Revenue Hours	43.41%	797.86	14.71%	270.40	0.00%	-	26.21%	481.66	4.16%	76.45	1.92%	35.34	3.78%	69.52	5.37%	98.70	0.44%	8.06	100.00%	1,838.00
Auto Allowance	900.00	Revenue Hours	43.41%	390.68	14.71%	132.41	0.00%	-	26.21%	235.85	4.16%	37.43	1.92%	17.31	3.78%	34.04	5.37%	48.33	0.44%	3.95	100.00%	900.00
FICA 6.2%	83,429.00	Revenue Hours	43.41%	36,215.87	14.71%	12,273.97	0.00%	-	26.21%	21,863.27	4.16%	3,470.15	1.92%	1,604.28	3.78%	3,155.57	5.37%	4,480.07	0.44%	365.83	100.00%	83,429.00
Medicare 1.45%	19,538.00	Revenue Hours	43.41%	8,481.29	14.71%	2,874.41	0.00%	-	26.21%	5,120.10	4.16%	812.67	1.92%	375.70	3.78%	738.99	5.37%	1,049.17	0.44%	85.67	100.00%	19,538.00
NDPERS Pension 5.26%	75,642.00	Revenue Hours	43.41%	32,835.59	14.71%	11,128.36	0.00%	-	26.21%	19,822.62	4.16%	3,146.26	1.92%	1,454.54	3.78%	2,861.04	5.37%	4,061.91	0.44%	331.68	100.00%	75,642.00
NDPERS/City Pension .88%	3,358.00	Revenue Hours	43.41%	1,457.68	14.71%	494.02	0.00%	-	26.21%	879.99	4.16%	139.67	1.92%	64.57	3.78%	127.01	5.37%	180.32	0.44%	14.72	100.00%	3,358.00
NDPERS DC Required Contribution	28,347.00	Revenue Hours	43.41%	12,305.21	14.71%	4,170.37	0.00%	-	26.21%	7,428.57	4.16%	1,179.07	1.92%	545.09	3.78%	1,072.18	5.37%	1,522.21	0.44%	124.30	100.00%	28,347.00
NDPERS DC Add'l Contribution	16,168.00	Revenue Hours	43.41%	7,018.40	14.71%	2,378.62	0.00%	-	26.21%	4,236.96	4.16%	672.49	1.92%	310.90	3.78%	611.53	5.37%	868.21	0.44%	70.89	100.00%	16,168.00
Workers Compensation	-	Revenue Hours	43.41%	-	14.71%	-	0.00%	-	26.21%	-	4.16%	-	1.92%	-	3.78%	-	5.37%	-	0.44%	-	100.00%	-
Other Services Temp Personnel	2,000.00	Revenue Hours	43.41%	868.18	14.71%	294.24	0.00%	-	26.21%	524.12	4.16%	83.19	1.92%	38.46	3.78%	75.65	5.37%	107.40	0.44%	8.77	100.00%	2,000.00
Security Services	150,000.00	Revenue Hours	43.41%	65,113.81	14.71%	22,067.81	0.00%	-	26.21%	39,308.76	4.16%	6,239.12	1.92%	2,884.38	3.78%	5,673.51	5.37%	8,054.87	0.44%	657.73	100.00%	150,000.00
Bus Driver Services	-	Revenue Hours	43.41%	-	14.71%	-	0.00%	-	26.21%	-	4.16%	-	1.92%	-	3.78%	-	5.37%	-	0.44%	-	100.00%	-
Computer Services	6,200.00	Revenue Hours	43.41%	2,691.37	14.71%	912.14	0.00%	-	26.21%	1,624.76	4.16%	257.88	1.92%	119.22	3.78%	234.51	5.37%	332.93	0.44%	27.19	100.00%	6,200.00
Marketing/ Public Relat.	-	Revenue Hours	43.41%	-	14.71%	-	0.00%	-	26.21%	-	4.16%	-	1.92%	-	3.78%	-	5.37%	-	0.44%	-	100.00%	-
Credit Card Fees	11,500.00	Revenue Hours	43.41%	4,992.06	14.71%	1,691.87	0.00%	-	26.21%	3,013.67	4.16%	478.33	1.92%	221.14	3.78%	434.97	5.37%	617.54	0.44%	50.43	100.00%	11,500.00
Computer Equipment Repair	1,000.00	Revenue Hours	43.41%	434.09	14.71%	147.12	0.00%	-	26.21%	262.06	4.16%	41.59	1.92%	19.23	3.78%	37.82	5.37%	53.70	0.44%	4.38	100.00%	1,000.00
Maintenance Service Cont.	5,000.00	Revenue Hours	43.41%	2,170.46	14.71%	735.59	0.00%	-	26.21%	1,310.29	4.16%	207.97	1.92%	96.15	3.78%	189.12	5.37%	268.50	0.44%	21.92	100.00%	5,000.00
General Liability	29,348.00	Revenue Hours	43.41%	12,739.73	14.71%	4,317.64	0.00%	-	26.21%	7,690.89	4.16%	1,220.70	1.92%	564.34	3.78%	1,110.04	5.37%	1,575.96	0.44%	128.69	100.00%	29,348.00
Cellular Phone Service	4,990.00	Revenue Hours	43.41%	2,166.12	14.71%	734.12	0.00%	-	26.21%	1,307.67	4.16%	207.55	1.92%	95.95	3.78%	188.74	5.37%	267.96	0.44%	21.88	100.00%	4,990.00
Radio Systems	5,000.00	Revenue Hours	43.41%	2,170.46	14.71%	735.59	0.00%	-	26.21%	1,310.29	4.16%	207.97	1.92%	96.15	3.78%	189.12	5.37%	268.50	0.44%	21.92	100.00%	5,000.00
Other Communications	1,600.00	Revenue Hours	43.41%	694.55	14.71%	235.39	0.00%	-	26.21%	419.29	4.16%	66.55	1.92%	30.77	3.78%	60.52	5.37%	85.92	0.44%	7.02	100.00%	1,600.00
Legal Publications	1,450.00	Revenue Hours	43.41%	629.43	14.71%	213.32	0.00%	-	26.21%	379.98	4.16%	60.31	1.92%	27.88	3.78%	54.84	5.37%	77.86	0.44%	6.36	100.00%	1,450.00
Custom Printed Forms	14,000.00	Revenue Hours	43.41%	6,077.29	14.71%	2,059.66	0.00%	-	26.21%	3,668.82	4.16%	582.32	1.92%	269.21	3.78%	529.53	5.37%	751.79	0.44%	61.39	100.00%	14,000.00
In State Travel Expenses	1,100.00	Revenue Hours	43.41%	477.50	14.71%	161.83	0.00%	-	26.21%	288.26	4.16%	45.75	1.92%	21.15	3.78%	41.61	5.37%	59.07	0.44%	4.82	100.00%	1,100.00
Out of State Travel Exp	17,617.00	Revenue Hours	43.41%	7,647.40	14.71%	2,591.79	0.00%	-	26.21%	4,616.68	4.16%	732.76	1.92%	338.76	3.78%	666.34	5.37%	946.02	0.44%	77.25	100.00%	17,617.00
Due & Membership Instate	2,500.00	Revenue Hours	43.41%	1,085.23	14.71%	367.80	0.00%	-	26.21%	655.15	4.16%	103.99	1.92%	48.07	3.78%	94.56	5.37%	134.25	0.44%	10.96	100.00%	2,500.00
Dues & Membership Outstate	6,500.00	Revenue Hours	43.41%	2,821.60	14.71%	956.27	0.00%	-	26.21%	1,703.38	4.16%	270.36	1.92%	124.99	3.78%	245.85	5.37%	349.04	0.44%	28.50	100.00%	6,500.00
Seminar & Conf. Instate	5,250.00	Revenue Hours	43.41%	2,278.98	14.71%	772.37	0.00%	-	26.21%	1,375.81	4.16%	218.37	1.92%	100.95	3.78%	198.57	5.37%	281.92	0.44%	23.02	100.00%	5,250.00
Seminar & Conf. Outstate	4,000.00	Revenue Hours	43.41%	1,736.37	14.71%	588.47	0.00%	-	26.21%	1,048.23	4.16%	166.38	1.92%	76.92	3.78%	151.29	5.37%	214.80	0.44%	17.54	100.00%	4,000.00
Office Supplies	36,600.00	Revenue Hours	43.41%	15,887.77	14.71%	5,384.55	0.00%	-	26.21%	9,591.34	4.16%	1,522.34	1.92%	703.79	3.78%	1,384.34	5.37%	1,965.39	0.44%	160.49	100.00%	36,600.00
Postage	2,350.00	Revenue Hours	43.41%	1,020.12	14.71%	345.73	0.00%	-	26.21%	615.84	4.16%	97.75	1.92%	45.19	3.78%	88.89	5.37%	126.19	0.44%	10.30	100.00%	2,350.00
Miscellaneous	2,440.00	Revenue Hours	43.41%	1,059.18	14.71%	358.97	0.00%	-	26.21%	639.42	4.16%	101.49	1.92%	46.92	3.78%	92.29	5.37%	131.03	0.44%	10.70	100.00%	2,440.00
Safety Compliance	2,600.00	Revenue Hours	43.41%	1,128.64	14.71%	382.51	0.00%	-	26.21%	681.35	4.16%	108.14	1.92%	50.00	3.78%	98.34	5.37%	139.62	0.44%	11.40	100.00%	2,600.00
Bad Debt	-	Revenue Hours	43.41%	-	14.71%	-	0.00%	-	26.21%	-	4.16%	-	1.92%	-	3.78%	-	5.37%	-	0.44%	-	100.00%	-
Special Assessment Princ	25.00	Revenue Hours	43.41%	10.85	14.71%	3.68	0.00%	-	26.21%	6.55	4.16%	1.04	1.92%	0.48	3.78%	0.95	5.37%	1.34	0.44%	0.11	100.00%	25.00
Interest on Other Debt	15.00	Revenue Hours	43.41%	6.51	14.71%	2.21	0.00%	-	26.21%	3.93	4.16%	0.62	1.92%	0.29	3.78%	0.57	5.37%	0.81	0.44%	0.07	100.00%	15.00
Admin Total	2,214,923.00			961,480.54		325,856.67		-	580,439.18		92,127.74		42,591.26		83,775.97		118,939.49		9,712.16			2,214,923.00
Fixed Route																						
Full Time Staff	3,678,118.00	Revenue Hours	56.44%	2,076,044.44					34.07%	1,253,293.74			2.50%	91,963.73			6.98%	256,816.09			100.00%	3,678,118.00
Full Time - Overtime	74,166.02	Revenue Hours	56.44%	41,861.61					34.07%	25,271.57			2.50%	1,854.37			6.98%	5,178.47			100.00%	74,166.02
Temporary/Seasonal	134,589.00	Revenue Hours	56.44%	75,966.23					34.07%	45,860.29			2.50%	3,365.12			6.98%	9,397.37			100.00%	134,589.00
Health Insurance	1,084,131.00	Revenue Hours	56.44%	611,917.33					34.07%	369,410.28			2.50%	27,106.45			6.98%	75,696.94			100.00%	1,084,131.00
Dental Insurance	37,870.00	Revenue Hours	56.44%	21,375.01					34.07%	12,903.95			2.50%	946.86			6.98%	2,644.19			100.00%	37,870.00
Long Term Disability	213.00																					

FICA 6.2%	75,067.00	Ridership		68.10%	51,119.29			16.27%	12,213.73			15.63%	11,733.98			100.00%	75,067.00					
Medicare 1.45%	17,556.00	Ridership		68.10%	11,955.32			16.27%	2,856.44			15.63%	2,744.24			100.00%	17,556.00					
NDPERS Required Contribution	67,885.00	Ridership		68.10%	46,228.48			16.27%	11,045.18			15.63%	10,611.34			100.00%	67,885.00					
NDPERS Add'l Contribution	28,513.00	Ridership		68.10%	19,416.85			16.27%	4,639.19			15.63%	4,456.97			100.00%	28,513.00					
Workers Compensation	-	Ridership		68.10%	-			16.27%	-			15.63%	-			100.00%	-					
Overhead Cost Allocation	92,388.00	Ridership		68.10%	62,914.59			16.27%	15,031.93			15.63%	14,441.49			100.00%	92,388.00					
Bus Driver Services	-	Ridership		68.10%	-			16.27%	-			15.63%	-			100.00%	-					
Other Services	57,000.00	Ridership		68.10%	38,815.99			16.27%	9,274.15			15.63%	8,909.87			100.00%	57,000.00					
Automobile Liability	32,326.00	Ridership		68.10%	22,013.43			16.27%	5,259.58			15.63%	5,052.99			100.00%	32,326.00					
General Liability	4,685.00	Ridership		68.10%	3,190.40			16.27%	762.27			15.63%	732.33			100.00%	4,685.00					
Cellular Phone Service	8,500.00	Ridership		68.10%	5,788.35			16.27%	1,382.99			15.63%	1,328.66			100.00%	8,500.00					
Gasoline	145,000.00	Ridership		68.10%	98,742.42			16.27%	23,592.13			15.63%	22,665.45			100.00%	145,000.00					
Bad Debts	-	Ridership		68.10%	-			16.27%	-			15.63%	-			100.00%	-					
Paratransit Total	2,085,173.00				1,419,965.78				339,266.66				325,940.56				2,085,173.00					
Ground Transportation Terminal																						
Temporary/Seasonal	-	Revenue Hours	43.41%	-	14.71%	-	0.00%	-	26.21%	-	4.16%	-	1.92%	-	3.78%	-	0.44%	-				
FICA 6.2%	-	Revenue Hours	43.41%	-	14.71%	-	0.00%	-	26.21%	-	4.16%	-	1.92%	-	3.78%	-	0.44%	-				
Medicare 1.45%	-	Revenue Hours	43.41%	-	14.71%	-	0.00%	-	26.21%	-	4.16%	-	1.92%	-	3.78%	-	0.44%	-				
Ground Transportation Terminal Total	-				-				-				-				-					
Planning																						
Full Time Staff	43,704.00	Revenue Hours	43.41%	18,971.56	14.71%	6,429.68	0.00%	-	26.21%	11,453.00	4.16%	1,817.83	1.92%	840.39	3.78%	1,653.03	5.37%	2,346.87	0.44%	191.64	100.00%	43,704.00
Health Insurance	11,253.00	Revenue Hours	43.41%	4,884.84	14.71%	1,655.53	0.00%	-	26.21%	2,948.94	4.16%	468.06	1.92%	216.39	3.78%	425.63	5.37%	604.28	0.44%	49.34	100.00%	11,253.00
Dental Insurance	305.00	Revenue Hours	43.41%	132.40	14.71%	44.87	0.00%	-	26.21%	79.93	4.16%	11.54	1.92%	5.86	3.78%	11.54	5.37%	16.38	0.44%	1.34	100.00%	305.00
Long Term Disability	99.00	Revenue Hours	43.41%	42.98	14.71%	14.56	0.00%	-	26.21%	25.94	4.16%	4.12	1.92%	1.90	3.78%	3.74	5.37%	5.32	0.44%	0.43	100.00%	99.00
FICA 6.2%	2,323.00	Revenue Hours	43.41%	1,008.40	14.71%	341.76	0.00%	-	26.21%	608.76	4.16%	96.62	1.92%	44.67	3.78%	87.86	5.37%	124.74	0.44%	10.19	100.00%	2,323.00
Medicare 1.45%	543.00	Revenue Hours	43.41%	235.71	14.71%	79.89	0.00%	-	26.21%	142.30	4.16%	22.59	1.92%	10.44	3.78%	20.54	5.37%	29.16	0.44%	2.38	100.00%	543.00
NDPERS Pension 5.26%	4,047.00	Revenue Hours	43.41%	1,756.77	14.71%	595.39	0.00%	-	26.21%	1,060.55	4.16%	168.33	1.92%	77.82	3.78%	153.07	5.37%	217.32	0.44%	17.75	100.00%	4,047.00
Planning Services	24,100.00	Revenue Hours	43.41%	10,461.62	14.71%	3,545.56	0.00%	-	26.21%	6,315.61	4.16%	1,002.42	1.92%	463.42	3.78%	911.54	5.37%	1,294.15	0.44%	105.68	100.00%	24,100.00
Planning Total	86,374.00			37,494.27	12,707.23				22,635.03		3,592.65		1,660.91		3,266.96		4,638.21		378.74			86,374.00
Vehicle Preventative Maintenance																						
Full Time Staff	1,095,383.00	% of Direct x Revenue Miles	50.35%	551,544.10	5.19%	56,843.79	0.00%	-	32.17%	352,344.54	1.68%	18,348.64	2.79%	30,544.67	1.43%	15,672.14	5.64%	61,768.49	0.76%	8,316.63	100.00%	1,095,383.00
Full Time Overtime	4,888.00	% of Direct x Revenue Miles	50.35%	2,461.19	5.19%	253.66	0.00%	-	32.17%	1,572.29	1.68%	81.88	2.79%	136.30	1.43%	69.93	5.64%	275.63	0.76%	37.11	100.00%	4,888.00
Full Time Banked Sick	1,425.00	% of Direct x Revenue Miles	50.35%	717.51	5.19%	73.95	0.00%	-	32.17%	458.37	1.68%	23.87	2.79%	39.74	1.43%	20.39	5.64%	80.36	0.76%	10.82	100.00%	1,425.00
Part Time with Benefits	44,591.00	% of Direct x Revenue Miles	50.35%	22,452.33	5.19%	2,314.00	0.00%	-	32.17%	14,343.29	1.68%	746.94	2.79%	1,243.42	1.43%	637.98	5.64%	2,514.48	0.76%	338.55	100.00%	44,591.00
Temporary/Seasonal	19,968.00	% of Direct x Revenue Miles	50.35%	10,054.23	5.19%	1,036.22	0.00%	-	32.17%	6,422.97	1.68%	334.48	2.79%	556.81	1.43%	285.69	5.64%	1,125.99	0.76%	151.61	100.00%	19,968.00
Health Insurance	294,096.00	% of Direct x Revenue Miles	50.35%	148,082.37	5.19%	15,261.81	0.00%	-	32.17%	94,599.90	1.68%	4,926.37	2.79%	8,200.84	1.43%	4,207.76	5.64%	16,584.03	0.76%	2,232.91	100.00%	294,096.00
Dental Insurance	10,384.00	% of Direct x Revenue Miles	50.35%	5,228.52	5.19%	538.87	0.00%	-	32.17%	3,340.15	1.68%	173.94	2.79%	289.56	1.43%	148.57	5.64%	585.55	0.76%	78.84	100.00%	10,384.00
Long Term Disability	2,870.00	% of Direct x Revenue Miles	50.35%	1,445.09	5.19%	148.94	0.00%	-	32.17%	923.17	1.68%	48.08	2.79%	80.03	1.43%	41.06	5.64%	161.84	0.76%	21.79	100.00%	2,870.00
Auto Allowance	-	% of Direct x Revenue Miles	50.35%	-	5.19%	-	0.00%	-	32.17%	-	1.68%	-	2.79%	-	1.43%	-	5.64%	-	0.76%	-	100.00%	-
FICA 6.2%	81,219.00	% of Direct x Revenue Miles	50.35%	40,895.16	5.19%	4,214.78	0.00%	-	32.17%	26,125.17	1.68%	1,360.49	2.79%	2,264.79	1.43%	1,162.04	5.64%	4,579.93	0.76%	616.65	100.00%	81,219.00
Medicare 1.45%	18,995.00	% of Direct x Revenue Miles	50.35%	9,564.31	5.19%	985.73	0.00%	-	32.17%	6,109.99	1.68%	318.18	2.79%	529.67	1.43%	271.77	5.64%	1,071.13	0.76%	144.22	100.00%	18,995.00
City Pension	5,157.00	% of Direct x Revenue Miles	50.35%	2,596.64	5.19%	267.62	0.00%	-	32.17%	1,658.82	1.68%	86.38	2.79%	143.80	1.43%	73.78	5.64%	290.80	0.76%	39.15	100.00%	5,157.00
NDPERS Pension 5.26%	121,261.00	% of Direct x Revenue Miles	50.35%	61,056.99	5.19%	6,292.72	0.00%	-	32.17%	39,005.22	1.68%	2,031.23	2.79%	3,381.35	1.43%	1,734.94	5.64%	6,837.89	0.76%	920.67	100.00%	121,261.00
NDPERS/City Pension .88%	1,618.00	% of Direct x Revenue Miles	50.35%	814.69	5.19%	83.96	0.00%	-	32.17%	520.45	1.68%	27.10	2.79%	45.12	1.43%	23.15	5.64%	91.24	0.76%	12.28	100.00%	1,618.00
Actuarial Contribution	-	% of Direct x Revenue Miles	50.35%	-	5.19%	-	0.00%	-	32.17%	-	1.68%	-	2.79%	-	1.43%	-	5.64%	-	0.76%	-	100.00%	-
Building Repairs	-	% of Direct x Revenue Miles	50.35%	-	5.19%	-	0.00%	-	32.17%	-	1.68%	-	2.79%	-	1.43%	-	5.64%	-	0.76%	-	100.00%	-
General Equipment Repair	15,000.00	% of Direct x Revenue Miles	50.35%	7,552.76	5.19%	778.41	0.00%	-	32.17%	4,824.95	1.68%	251.26	2.79%	418.27	1.43%	214.61	5.64%	845.85	0.76%	113.89	100.00%	15,000.00
Bus Repairs/Parts	690,000.00	% of Direct x Revenue Miles	50.35%	347,426.82	5.19%	35,806.85	0.00%	-	32.17%	221,947.70	1.68%	11,558.12	2.79%	19,240.60	1.43%	9,872.14	5.64%	38,909.00	0.76%	5,238.78	100.00%	690,000.00
Outside Mechanic Service	295,500.00	% of Direct x Revenue Miles	50.35%	148,789.31	5.19%	15,334.67	0.00%	-	32.17%	95,051.51	1.68%	4,949.89	2.79%	8,239.99	1.43%	4,227.85	5.64%	16,663.20	0.76%	2,243.57	100.00%	295,500.00
Vehicle Repair Supplies	19,000.00	% of Direct x Revenue Miles	50.35%	9,566.83	5.19%	985.99	0.00%	-	32.17%	6,111.60	1.68%	318.27	2.79%	529.81	1.43%	271.84	5.64%	1,071.41	0.76%	144.26	100.00%	19,000.00
Small Tools	10,000.00	% of Direct x Revenue Miles	50.35%	5,035.17	5.19%	518.94	0.00%	-	32.17%	3,216.63	1.68%	167.51	2.79%	278.85	1.43%	143.07	5.64%	563.90	0.76%	75.92	100.00%	10,000.00
Uniforms	22,000.00	% of Direct x Revenue Miles	50.35%	11,077.38	5.19%	1,141.67	0.00%	-	32.17%	7,076.59	1.68%	368.52	2.79%	613.47	1.43%	314.76	5.64%	1,240.58	0.76%	167.03	100.00%	22,000.00
Vehicle Preventative Maintenance Total	2,753,355.00			1,386,361.40	142,882.56				885,653.34		46,121.16		76,777.09		39,393.49		155,261.29		20,904.68			2,753,355.00
Microtransit																						
Full Time Staff	2,000.00	Revenue Hours					0.00%	-													100.00%	2,000.00
Full Time Overtime	423.00	Revenue Hours					0.00%	-													100.00%	423.00
Temporary/Seasonal	767.00	Revenue Hours					0.00%	-													100.00%	767.00
FICA 6.2%	198.00	Revenue Hours					0.00%	-													100.00%	198.00
Medicare 1.45%	47.00	Revenue Hours					0.00%	-													100.00%	47.00
Overhead Cost Allocation	14,277.00	Revenue Hours					0.00%	-													100.00%	14,277.00
Bus Driver Services	-	Revenue Hours					0.00%	-													100.00%	-
Other Services	12,000.00	Revenue Hours					0.00%	-													100.00%	12,000.00
Automobile Liability	6,600.00	Revenue Hours					0.00%	-													100.00%	6,600.00
General Liability	-	Revenue Hours					0.00%	-													100.00%	-
Cellular Phone Service	480.00	Revenue Hours					0.00%	-													100.00%	480.00
Gasoline	2,200.00	Revenue Hours					0.00%	-													100.00%	2,200.00
Microtransit Total	38,992.00																					38,992.00
Building - Preventative Maintenance																						
Full Time Staff	78,578.00	Revenue Hours	43.41%	34,110.09	14.71%	11,560.30	0.00%	-	26.21%	20,592.03	4.16%	3,268.38	1.92%	1,510.99	3.78%	2,972.09	5.37%	4,219.57	0.44%	344.55	100.00%	

Computer Equipment Repair	-	Revenue Hours	43.41%	-	14.71%	-	0.00%	-	26.21%	-	4.16%	-	1.92%	-	3.78%	-	5.37%	-	0.44%	-	100.00%	-
Maintenance Service Cont.	1,000.00	Revenue Hours	43.41%	434.09	14.71%	147.12	0.00%	-	26.21%	262.06	4.16%	41.59	1.92%	19.23	3.78%	37.82	5.37%	53.70	0.44%	4.38	100.00%	1,000.00
Other Repairs	2,000.00	Revenue Hours	43.41%	868.18	14.71%	294.24	0.00%	-	26.21%	524.12	4.16%	83.19	1.92%	38.46	3.78%	75.65	5.37%	107.40	0.44%	8.77	100.00%	2,000.00
Operating Leases	500.00	Revenue Hours	43.41%	217.05	14.71%	73.56	0.00%	-	26.21%	131.03	4.16%	20.80	1.92%	9.61	3.78%	18.91	5.37%	26.85	0.44%	2.19	100.00%	500.00
Property Insurance	93,455.00	Revenue Hours	43.41%	40,568.08	14.71%	13,748.98	0.00%	-	26.21%	24,490.67	4.16%	3,887.18	1.92%	1,797.07	3.78%	3,534.79	5.37%	5,018.45	0.44%	409.79	100.00%	93,455.00
Reference Material	2,500.00	Revenue Hours	43.41%	1,085.23	14.71%	367.80	0.00%	-	26.21%	655.15	4.16%	103.99	1.92%	48.07	3.78%	94.56	5.37%	134.25	0.44%	10.96	100.00%	2,500.00
Janitorial Supplies	20,000.00	Revenue Hours	43.41%	8,681.84	14.71%	2,942.37	0.00%	-	26.21%	5,241.17	4.16%	831.88	1.92%	384.58	3.78%	756.47	5.37%	1,073.98	0.44%	87.70	100.00%	20,000.00
Gasoline	20,500.00	Revenue Hours	43.41%	8,898.89	14.71%	3,015.93	0.00%	-	26.21%	5,372.20	4.16%	852.68	1.92%	394.20	3.78%	775.38	5.37%	1,100.83	0.44%	89.89	100.00%	20,500.00
Other Fuels	50,000.00	Revenue Hours	43.41%	21,704.60	14.71%	7,355.94	0.00%	-	26.21%	13,102.92	4.16%	2,079.71	1.92%	961.46	3.78%	1,891.17	5.37%	2,684.96	0.44%	219.24	100.00%	50,000.00
Natural Gas	43,961.00	Revenue Hours	43.41%	19,083.12	14.71%	6,467.49	0.00%	-	26.21%	11,520.35	4.16%	1,828.52	1.92%	845.34	3.78%	1,662.76	5.37%	2,360.67	0.44%	192.76	100.00%	43,961.00
Electricity	66,839.00	Revenue Hours	43.41%	29,014.28	14.71%	9,833.27	0.00%	-	26.21%	17,515.72	4.16%	2,780.11	1.92%	1,285.26	3.78%	2,528.08	5.37%	3,589.20	0.44%	293.08	100.00%	66,839.00
Propane	500.00	Revenue Hours	43.41%	217.05	14.71%	73.56	0.00%	-	26.21%	131.03	4.16%	20.80	1.92%	9.61	3.78%	18.91	5.37%	26.85	0.44%	2.19	100.00%	500.00
Building - Preventative Maintenance Total	663,470.00			288,007.07		97,608.87		-	173,867.89		27,596.44		12,758.01		25,094.71		35,627.78		2,909.23		663,470.00	
Mobility Management																						
Full Time Staff	100,166.00	Revenue Hours	43.41%	43,481.27	14.71%	14,736.30	0.00%	-	26.21%	26,249.34	4.16%	4,166.31	1.92%	1,926.11	3.78%	3,788.62	5.37%	5,378.83	0.44%	439.22	100.00%	100,166.00
Full Time Banked Sick	2,859.00	Revenue Hours	43.41%	1,241.07	14.71%	420.61	0.00%	-	26.21%	749.22	4.16%	118.92	1.92%	54.98	3.78%	108.14	5.37%	153.53	0.44%	12.54	100.00%	2,859.00
Health Insurance	22,506.00	Revenue Hours	43.41%	9,769.68	14.71%	3,311.05	0.00%	-	26.21%	5,897.89	4.16%	936.12	1.92%	432.77	3.78%	851.25	5.37%	1,208.55	0.44%	98.69	100.00%	22,506.00
Dental Insurance	611.00	Revenue Hours	43.41%	265.23	14.71%	89.89	0.00%	-	26.21%	160.12	4.16%	25.41	1.92%	11.75	3.78%	23.11	5.37%	32.81	0.44%	2.68	100.00%	611.00
Long Term Disability	229.00	Revenue Hours	43.41%	99.41	14.71%	33.69	0.00%	-	26.21%	60.01	4.16%	9.53	1.92%	4.40	3.78%	8.66	5.37%	12.30	0.44%	1.00	100.00%	229.00
FICA 6.2%	5,997.00	Revenue Hours	43.41%	2,603.25	14.71%	882.27	0.00%	-	26.21%	1,571.56	4.16%	249.44	1.92%	115.32	3.78%	226.83	5.37%	322.03	0.44%	26.30	100.00%	5,997.00
Medicare 1.45%	1,402.00	Revenue Hours	43.41%	608.60	14.71%	206.26	0.00%	-	26.21%	367.41	4.16%	58.31	1.92%	26.96	3.78%	53.03	5.37%	75.29	0.44%	6.15	100.00%	1,402.00
NDPERS Pension 5.26%	9,276.00	Revenue Hours	43.41%	4,026.64	14.71%	1,364.67	0.00%	-	26.21%	2,430.85	4.16%	385.83	1.92%	178.37	3.78%	350.85	5.37%	498.11	0.44%	40.67	100.00%	9,276.00
Workers Compensation	-	Revenue Hours	43.41%	-	14.71%	-	0.00%	-	26.21%	-	4.16%	-	1.92%	-	3.78%	-	5.37%	-	0.44%	-	100.00%	-
Cellular Phone Service	550.00	Revenue Hours	43.41%	238.75	14.71%	80.92	0.00%	-	26.21%	144.13	4.16%	22.88	1.92%	10.58	3.78%	20.80	5.37%	29.53	0.44%	2.41	100.00%	550.00
Marketing	500.00	Revenue Hours	43.41%	217.05	14.71%	73.56	0.00%	-	26.21%	131.03	4.16%	20.80	1.92%	9.61	3.78%	18.91	5.37%	26.85	0.44%	2.19	100.00%	500.00
Custom Printed Forms	2,000.00	Revenue Hours	43.41%	868.18	14.71%	294.24	0.00%	-	26.21%	524.12	4.16%	83.19	1.92%	38.46	3.78%	75.65	5.37%	107.40	0.44%	8.77	100.00%	2,000.00
In State Travel Expenses	750.00	Revenue Hours	43.41%	325.57	14.71%	110.34	0.00%	-	26.21%	196.54	4.16%	31.20	1.92%	14.42	3.78%	28.37	5.37%	40.27	0.44%	3.29	100.00%	750.00
Dues & Membership	500.00	Revenue Hours	43.41%	217.05	14.71%	73.56	0.00%	-	26.21%	131.03	4.16%	20.80	1.92%	9.61	3.78%	18.91	5.37%	26.85	0.44%	2.19	100.00%	500.00
Postage	-	Revenue Hours	43.41%	-	14.71%	-	0.00%	-	26.21%	-	4.16%	-	1.92%	-	3.78%	-	5.37%	-	0.44%	-	100.00%	-
Out of State Travel Exp	1,250.00	Revenue Hours	43.41%	542.62	14.71%	183.90	0.00%	-	26.21%	327.57	4.16%	51.99	1.92%	24.04	3.78%	47.28	5.37%	67.12	0.44%	5.48	100.00%	1,250.00
Seminar & Conf. Instate	100.00	Revenue Hours	43.41%	43.41	14.71%	14.71	0.00%	-	26.21%	26.21	4.16%	4.16	1.92%	1.92	3.78%	3.78	5.37%	5.37	0.44%	0.44	100.00%	100.00
Office Supplies	-	Revenue Hours	43.41%	-	14.71%	-	0.00%	-	26.21%	-	4.16%	-	1.92%	-	3.78%	-	5.37%	-	0.44%	-	100.00%	-
Mobility Management Total	148,696.00			64,547.76		21,875.97		-	38,967.04		6,184.88		2,859.31		5,624.19		7,984.85		652.01		148,696.00	
Transit Maintenance Facility																						
Full Time Staff	-	% of Direct x Revenue Miles	50.35%	-	5.19%	-	0.00%	-	32.17%	-	1.68%	-	2.79%	-	1.43%	-	5.64%	-	0.76%	-	100.00%	-
Full Time - Overtime	-	% of Direct x Revenue Miles	50.35%	-	5.19%	-	0.00%	-	32.17%	-	1.68%	-	2.79%	-	1.43%	-	5.64%	-	0.76%	-	100.00%	-
Full Time Banked Sick	-	% of Direct x Revenue Miles	50.35%	-	5.19%	-	0.00%	-	32.17%	-	1.68%	-	2.79%	-	1.43%	-	5.64%	-	0.76%	-	100.00%	-
FICA 6.2%	-	% of Direct x Revenue Miles	50.35%	-	5.19%	-	0.00%	-	32.17%	-	1.68%	-	2.79%	-	1.43%	-	5.64%	-	0.76%	-	100.00%	-
Medicare 1.45%	-	% of Direct x Revenue Miles	50.35%	-	5.19%	-	0.00%	-	32.17%	-	1.68%	-	2.79%	-	1.43%	-	5.64%	-	0.76%	-	100.00%	-
Computer Services	-	% of Direct x Revenue Miles	50.35%	-	5.19%	-	0.00%	-	32.17%	-	1.68%	-	2.79%	-	1.43%	-	5.64%	-	0.76%	-	100.00%	-
Other Services	-	% of Direct x Revenue Miles	50.35%	-	5.19%	-	0.00%	-	32.17%	-	1.68%	-	2.79%	-	1.43%	-	5.64%	-	0.76%	-	100.00%	-
Water and Sewer	-	% of Direct x Revenue Miles	50.35%	-	5.19%	-	0.00%	-	32.17%	-	1.68%	-	2.79%	-	1.43%	-	5.64%	-	0.76%	-	100.00%	-
Garbage Pickup	-	% of Direct x Revenue Miles	50.35%	-	5.19%	-	0.00%	-	32.17%	-	1.68%	-	2.79%	-	1.43%	-	5.64%	-	0.76%	-	100.00%	-
Other Repairs	-	% of Direct x Revenue Miles	50.35%	-	5.19%	-	0.00%	-	32.17%	-	1.68%	-	2.79%	-	1.43%	-	5.64%	-	0.76%	-	100.00%	-
Operating Leases	-	% of Direct x Revenue Miles	50.35%	-	5.19%	-	0.00%	-	32.17%	-	1.68%	-	2.79%	-	1.43%	-	5.64%	-	0.76%	-	100.00%	-
Property Insurance	-	% of Direct x Revenue Miles	50.35%	-	5.19%	-	0.00%	-	32.17%	-	1.68%	-	2.79%	-	1.43%	-	5.64%	-	0.76%	-	100.00%	-
Reference Materials	-	% of Direct x Revenue Miles	50.35%	-	5.19%	-	0.00%	-	32.17%	-	1.68%	-	2.79%	-	1.43%	-	5.64%	-	0.76%	-	100.00%	-
Gasoline	-	% of Direct x Revenue Miles	50.35%	-	5.19%	-	0.00%	-	32.17%	-	1.68%	-	2.79%	-	1.43%	-	5.64%	-	0.76%	-	100.00%	-
Other Fuels	-	% of Direct x Revenue Miles	50.35%	-	5.19%	-	0.00%	-	32.17%	-	1.68%	-	2.79%	-	1.43%	-	5.64%	-	0.76%	-	100.00%	-
Natural Gas	-	% of Direct x Revenue Miles	50.35%	-	5.19%	-	0.00%	-	32.17%	-	1.68%	-	2.79%	-	1.43%	-	5.64%	-	0.76%	-	100.00%	-
Electricity	-	% of Direct x Revenue Miles	50.35%	-	5.19%	-	0.00%	-	32.17%	-	1.68%	-	2.79%	-	1.43%	-	5.64%	-	0.76%	-	100.00%	-
Propane	-	% of Direct x Revenue Miles	50.35%	-	5.19%	-	0.00%	-	32.17%	-	1.68%	-	2.79%	-	1.43%	-	5.64%	-	0.76%	-	100.00%	-
Transit Maintenance Facility Total	-			-		-		-	-		-		-		-		-		-		-	
Expense Total	15,235,269.02			6,826,791.85		2,020,897.08		-	4,170,003.76		514,889.51		317,774.97		483,095.88		828,267.15		73,548.82		15,235,269.02	

		8,847,688.93						4,684,893.28						800,870.85						901,815.97					
Revenue		Fargo						Moorhead						West Fargo						NDSU					
Account Description																									

5307 Apportionment Calculation #1 - Population	693,427.39	76.54%	530,719.47							23.46%	162,707.92					100.00%	693,427.39					
5307 Apportionment Calculation #2 - Population X Density	693,427.39	75.52%	523,665.37							24.48%	169,762.02					100.00%	693,427.39					
5307 Apportionment Calculation #3 - Bus Revenue Miles	1,386,854.77	85.66%	1,188,014.20							4.74%	65,792.57		9.59%	133,048.00		100.00%	1,386,854.77					
5307 Apportionment Calculation #4 - Bus Incentive	281,036.65	74.43%	209,180.49							4.64%	13,041.34		20.93%	58,814.82		100.00%	281,036.65					
5310 Mobility Management	119,141.00	43.41%	51,718.16	14.71%	17,527.87	0.00%	-	26.21%	31,221.90	4.16%	4,955.56	1.92%	2,290.99	3.78%	4,506.32	5.37%	6,397.77	0.44%	522.42	100.00%	119,141.00	
Total Federal Revenue	3,173,887.19		2,758,005.04		17,527.87		-		31,221.90		4,955.56		158,887.48		4,506.32		198,260.59		522.42		3,173,887.19	
Revenue Total	5,591,096.19		3,811,629.06		704,393.67		-		479,159.24		44,516.46		187,122.80		162,317.33		201,096.12		861.52		5,591,096.19	
Agency Total by Transit Type	9,644,172.83		3,015,162.79		1,316,503.41		-		3,690,844.53		470,373.06		130,652.16		320,778.55		627,171.03		72,687.30		9,644,172.83	
Agency Total																						
	1,042,324.00																					
	3,054,746.19																					
Agency Totals - ND Revenue	13,741,243.02																					

Federal Rev. not to exceed 1/2 of fixed route expenses
\$ 254,707.35

MATBUS Fixed Route			
Route	Ridership	Rev. Hours	Rev. Mileage
Fargo			
Route 11	47,432	4,401.00	52,630.00
Route 13	110,642	7,933.00	83,534.00
Route 14	96,628	13,073.00	191,121.00
Route 15	235,592	13,818.00	173,140.00
Route 16	-	-	-
Route 17	22,148	2,431.00	29,798.00
Route 18	33,418	7,138.00	106,832.00
Route 20 (Fargo)	19,998	3,280.26	47,295.30
Route 24 (Fargo)	20,723	3,760.40	49,345.42
Moorhead			
Route 1	63,700	4,861.00	59,401.00
Route 2	76,734	5,609.00	90,163.00
Route 3	65,856	4,861.00	80,304.00
Route 4	119,756	9,722.00	112,872.00
Route 5	48,804	4,861.00	70,387.00
Route 6	12,740	2,073.00	25,492.00
Route 9	5,978	1,714.00	29,961.00
LinkFM			
LinkFM	400	6.00	129.00
NDSU			
Route 31	52,900	1,700.00	25,638.00
Route 33	151,700	3,772.00	44,924.00
Route 34	45,500	1,435.00	11,606.00
West Fargo			
Route 20 (West Fargo)	10,302	1,473.74	23,294.70
Route 21			
Route 24 (West Fargo)	641	999.60	17,337.58
Agency Total			
Moorhead/Dilworth	393,968	33,707.00	468,709.00
West Fargo	10,943	2,473.34	40,632.28
NDSU	250,100	6,907.00	82,168.00
Fargo	586,581	55,834.66	733,695.72
Fixed Route Total	1,241,592	98,922.00	1,325,205.00
System Total	1,312,893	128,624.00	1,726,322.00

MAT Paratransit			
Paratransit	Ridership	Rev. Hours	Rev. Mileage
Fargo	45,286	18,923.00	246,680.00
Moorhead & Dilworth	10,820	5,350.00	79,626.00
West Fargo	10,395	4,865.00	68,011.00
Total	66,501	29,138.00	394,317.00

Fixed Route Ridership by Customer					
Total	Elderly	Disabled	Adult	Child	Youth
Moorhead/Dilworth					
West Fargo	1,339	2,471	8,321	158	186
Fargo	32,711	65,550	675,999	138	82,424
MATBUS	34,049	68,021	684,320	296	82,610

MATBUS Microtransit			
On-Demand	Ridership	Rev. Hours	Rev. Mileage
Fargo			
NDSU	4,800	564.00	6,800.00
Total	4,800	564.00	6,800.00

West Fargo Split - Rev. Hours/Miles						
Route	Ridership	W.F. %	Rev. Hours	W.F. %	Rev. Mileage	W.F. %
Route 20	30,300	34.00%	4,754.00	31.00%	70,590.00	33.00%
Route 24	21,800	3.00%	4,760.00	21.00%	66,683.00	26.00%
Total	52,100	37.00%	9,514	52.00%	137,273	59.00%

Senior Ride			
Senior Ride	Ridership	Rev. Hours	Rev. Mileage
Moorhead & Dilworth	7,300	6,300.00	70,300.00
Total	7,300	6,300	70,300

West Fargo Ridership Split - Route 20					
Route	Elderly	Disabled	Adult	Child	Youth
Route 20 - Fargo	2,498	4,614	14,759	279	341
Route 20 - West Fargo	1,287	2,377	7,603	144	176
Total	3,785	6,991	22,362	423	517

Special Service			
Agency	Ridership	Rev. Hours	Rev. Mileage
Fargo			
Moorhead			
West Fargo			
NDSU			
Total	-	-	-

West Fargo Ridership Split - Route 24					
Route	Elderly	Disabled	Adult	Child	Youth
Route 24 - Fargo	1,668	3,042	23,208	454	327
Route 24 - West Fargo	52	94	718	14	10
Total	1,720	3,136	23,926	468	337

Special Service Rate	
\$	122.75

Faster Maintenance Costs 2024			
	Maint Costs	Percentage	
Fargo	\$ 676,653.53	48.6%	Fixed Route 90.95%
Moorhead	\$ 573,145.23	41.1%	Paratransit 8.30%
Paratransit	\$ 115,582.02	8.3%	MicroTransit 0.76%
Non Rev	\$ 17,395.02	1.2%	
Microtransit	\$ 10,578.96	0.8%	
Total	\$ 1,393,354.76		

	Fixed Route	Paratransit	Microtransit
Revenue Hour %	76.91%	22.65%	0.44%
Overtime	\$ 74,166.02	\$ 21,845.99	\$ 422.85
Temp/Non-Benefited	\$ 134,588.80	\$ 39,643.85	\$ 767.35
Overtime	\$ 96,434.87		
Temp/Non-Benefited	\$ 175,000.00		
Fixed Route Wages/ Benefits	\$ 5,010,000.00		
Paratransit Wages/Benefits	\$ 1,377,750.00		
Microtransit Wages/Benefits	\$ 41,241.01		

DIV 60 Transit Administration

Account Number	Account Description		
Salaries			
551-2560-491.11-00	Full Time Staff	\$	1,364,808.00
551-2560-491.11-01	Full Time - Overtime		
551-2560-491.14-00	Temporary/Seasonal	\$	8,715.00
Salaries Total		\$	1,373,523.00
Employee Benefits			
551-2560-491.20-01	Health Insurance	\$	288,558.00
551-2560-491.20-03	Dental Insurance	\$	10,537.00
551-2560-491.20-04	Long Term Disability	\$	1,838.00
551-2560-491.20-05	Auto Allowance	\$	900.00
551-2560-491.21-01	FICA 6.2%	\$	83,429.00
551-2560-491.21-02	Medicare 1.45%	\$	19,538.00
551-2560-491.22-04	NDPERS Pension 5.26%	\$	75,642.00
551-2560-491.22-05	NDPERS/City Pension .88%	\$	3,358.00
551-2560-491.22-10	NDPERS DC Required Contributio	\$	28,347.00
551-2560-491.22-11	NDPERS DC Add'l Contribution	\$	16,168.00
551-2560-491.25-00	Workers Compensation		
Employee Benefits Total		\$	528,315.00
Other Services			
551-2560-491.33-03	Overhead Cost Allocation	\$	-
551-2560-491.33-71	Other Services Temp Personnel	\$	2,000.00
551-2560-491.33-80	Security Services	\$	150,000.00
551-2560-491.33-86	Bus Driver Services	\$	-
551-2560-491.34-15	Computer Services	\$	6,200.00
551-2560-491.34-20	Marketing/ Public Relat.	\$	-
551-2560-491.34-36	Credit Card Fees	\$	11,500.00
551-2560-491.38-99	Other Services	\$	-
551-2560-491.42-06	Cleaning Service Contract	\$	-
551-2560-491.42-20	Snow Clearing	\$	-
Other Services Total		\$	169,700.00
Repairs & Maintenance			
551-2560-491.43-10	Building Repairs	\$	-
551-2560-491.43-20	General Equipment Repair	\$	-
551-2560-491.43-21	Computer Equipment Repair	\$	1,000.00
551-2560-491.43-50	Maintenance Service Cont.	\$	5,000.00
Repairs & Maintenance Total		\$	6,000.00
Insurance			
551-2560-491.52-10	Property Insurance	\$	-
551-2560-491.52-20	Automobile Liability	\$	-
551-2560-491.52-30	General Liability	\$	29,348.00
Insurance Total		\$	29,348.00
Communications			
551-2560-491.53-20	Cellular Phone Service	\$	4,990.00
551-2560-491.53-30	Radio Systems	\$	5,000.00
551-2560-491.53-60	Other Communications	\$	1,600.00
Communications Total		\$	11,590.00
Advertising & Printing			
551-2560-491.54-10	Legal Publications	\$	1,450.00
551-2560-491.55-10	Custom Printed Forms	\$	14,000.00
Advertising & Printing Total		\$	15,450.00

Travel

551-2560-491.56-60	In State Travel Expenses	\$	1,100.00
551-2560-491.57-60	Out of State Travel Exp	\$	17,617.00
	Travel Total	\$	18,717.00

Education

551-2560-491.59-10	Due & Membership Instate	\$	2,500.00
551-2560-491.59-11	Dues & Membership Outstate	\$	6,500.00
551-2560-491.59-20	Seminar & Conf. Instate	\$	5,250.00
551-2560-491.59-21	Seminar & Conf. Outstate	\$	4,000.00
	Education Total	\$	18,250.00

General Supplies

551-2560-491.61-10	Office Supplies	\$	36,600.00
551-2560-491.61-50	Postage	\$	2,350.00
	General Supplies Total	\$	38,950.00

Energy

551-2560-491.62-51	Electricity	\$	-
	Energy Total	\$	-

Miscellaneous

551-2560-491.68-10	Miscellaneous	\$	2,440.00
551-2560-491.68-50	Safety Compliance	\$	2,600.00
	Miscellaneous Total	\$	5,040.00

Bad Debt

551-2560-491.68-10	Bad Debt	\$	-
551-2560-491.80-12	Special Assessment Princ	\$	25.00
551-2560-491.80-21	Interest on Other Debt	\$	15.00
	Miscellaneous Total	\$	40.00

DIV 60 Transit Administration	\$	2,214,923.00
--------------------------------------	----	---------------------

DIV 61 Transit Fixed Route

Account Number	Account Description		
Salaries			
551-2561-491.11-00	Full Time Staff	\$	3,678,118.00
551-2561-491.11-01	Full Time - Overtime	\$	74,166.02
551-2561-491.14-00	Temporary/Seasonal	\$	134,589.00
Salaries Total			\$ 3,886,873.02
Employee Benefits			
551-2561-491.20-01	Health Insurance	\$	1,084,131.00
551-2561-491.20-03	Dental Insurance	\$	37,870.00
551-2561-491.20-04	Long Term Disability	\$	213.00
551-2561-491.20-05	Auto Allowance	\$	-
551-2561-491.21-01	FICA 6.2%	\$	240,644.00
551-2561-491.21-02	Medicare 1.45%	\$	56,280.00
551-2561-491.22-04	NDPERS Pension 5.26%	\$	8,804.00
551-2561-491.22-05	NDPERS/City Pension .88%	\$	-
551-2561-491.22-10	NDPERS Required Contribution	\$	181,839.00
551-2561-491.22-11	NDPERS Add'l Contribution	\$	103,709.00
551-2561-491.25-00	Workers Compensation	\$	-
Employee Benefits Total			\$ 1,713,490.00
Other Services			
551-2561-491.33-03	Overhead Cost Allocation	\$	304,790.00
551-2561-491.33-80	Security Services	\$	89,000.00
551-2561-491.33-86	Bus Driver Services	\$	-
551-2561-491.34-15	Computer Services	\$	-
551-2561-491.34-20	Marketing/ Public Relat.	\$	50,000.00
551-2561-491.38-99	Other Services	\$	89,257.00
551-2561-491.42-06	Cleaning Service Contract	\$	85,000.00
551-2561-491.42-20	Snow Clearing	\$	39,330.00
Other Services Total			\$ 657,377.00
Repairs & Maintenance			
551-2561-491.43-10	Building Repairs	\$	9,000.00
551-2561-491.43-20	General Equipment Repair	\$	12,000.00
551-2561-491.43-50	Maintenance Service Cont.	\$	-
551-2561-491.44-30	Operating Leases	\$	25,000.00
Repairs & Maintenance Total			\$ 46,000.00
Insurance			
551-2561-491.52-10	Property Insurance	\$	-
551-2561-491.52-20	Automobile Liability	\$	147,586.00
551-2561-491.52-30	General Liability	\$	-
Insurance Total			\$ 147,586.00
Communications			
551-2561-491.53-20	Cellular Phone Service	\$	26,960.00
Communications Total			\$ 26,960.00
Advertising & Printing			
551-2561-491.54-10	Legal Publications	\$	-
551-2561-491.55-10	Custom Printed Forms	\$	-
Advertising & Printing Total			\$ -

Travel

551-2561-491.56-60	In State Travel Expenses	\$	-
551-2561-491.57-60	Out of State Travel Exp	\$	-
Travel Total		\$	-

Education

551-2561-491.59-10	Due & Membership Instate	\$	-
551-2561-491.59-11	Dues & Membership Outstate	\$	-
551-2561-491.59-20	Seminar & Conf. Instate	\$	-
551-2561-491.59-21	Seminar & Conf. Outstate	\$	-
Education Total		\$	-

General Supplies

551-2561-491.61-10	Office Supplies	\$	3,000.00
551-2561-491.61-15	Farebox Cards	\$	42,000.00
551-2561-491.61-40	General Supplies	\$	-
General Supplies Total		\$	45,000.00

Energy

551-2561-491.62-51	Electricity	\$	-
551-2561-491.62-11	Diesel Fuel	\$	720,000.00
Energy Total		\$	720,000.00

Miscellaneous

551-2561-491.68-10	Miscellaneous	\$	1,000.00
Miscellaneous Total		\$	1,000.00

Bad Debt

551-2561-491.68-10	Bad Debt	\$	-
Miscellaneous Total		\$	-

DIV 61 Transit Fixed Route Total		\$	7,244,286.02
---	--	----	---------------------

DIV 62 Paratransit Service

Account Number	Account Description	
Salaries		
551-2562-491.11-00	Full Time Staff	\$ 1,160,678.00
551-2562-491.11-01	Full Time - Overtime	\$ 21,846.00
551-2562-491.14-00	Temporary/Seasonal	\$ 39,644.00
Salaries Total		\$ 1,222,168.00
Employee Benefits		
551-2562-491.20-01	Health Insurance	\$ 321,453.00
551-2562-491.20-03	Dental Insurance	\$ 12,216.00
551-2562-491.20-04	Long Term Disability	\$ 416.00
551-2562-491.21-01	FICA 6.2%	\$ 75,067.00
551-2562-491.21-02	Medicare 1.45%	\$ 17,556.00
551-2562-491.22-10	NDPERS Required Contribution	\$ 67,885.00
551-2562-491.22-11	NDPERS Add'l Contribution	\$ 28,513.00
551-2562-491.25-00	Workers Compensation	\$ -
Employee Benefits Total		\$ 523,106.00
Other Services		
551-2562-491.33-03	Overhead Cost Allocation	\$ 92,388.00
551-2562-491.33-71	Temp. Other Personnel	\$ -
551-2562-491.33-86	Bus Driver Services	\$ -
551-2562-491.34-15	Computer Services	\$ -
551-2562-491.38-99	Other Services	\$ 57,000.00
Other Services Total		\$ 149,388.00
Insurance		
551-2562-491.52-10	Property Insurance	\$ -
551-2562-491.52-20	Automobile Liability	\$ 32,326.00
551-2562-491.52-30	General Liability	\$ 4,685.00
Insurance Total		\$ 37,011.00
Communications		
551-2562-491.53-20	Cellular Phone Service	\$ 8,500.00
551-2562-491.53-60	Other Communications	\$ -
Communications Total		\$ 8,500.00
Travel		
551-2562-491.57-60	Out of State Travel Exp	\$ -
Travel Total		\$ -
Education		
551-2562-491.59-20	Seminar & Conf. Instate	\$ -
Education Total		\$ -
General Supplies		
551-2562-491.61-10	Office Supplies	\$ -
551-2562-491.61-40	General Supplies	\$ -
551-2562-491.61-50	Postage	\$ -
General Supplies Total		\$ -
Energy		
551-2562-491.62-10	Gasoline	\$ 145,000.00
Energy Total		\$ 145,000.00
Miscellaneous		
551-2562-491.68-10	Miscellaneous	\$ -
Miscellaneous Total		\$ -
Bad Debt		
551-2562-491.68-10	Bad Debt	\$ -
Miscellaneous Total		\$ -
DIV 62 Paratransit Total		\$ 2,085,173.00

DIV 63 Ground Transport Terminal

Account Number	Account Description		
Salaries			
551-2563-491.11-00	Full Time Staff	\$	-
551-2563-491.11-01	Full Time - Overtime	\$	-
551-2563-491.14-00	Temporary/Seasonal	\$	-
Salaries Total		\$	-

Employee Benefits			
551-2563-491.20-01	Health Insurance	\$	-
551-2563-491.20-03	Dental Insurance	\$	-
551-2563-491.20-04	Long Term Disability	\$	-
551-2563-491.21-01	FICA 6.2%	\$	-
551-2563-491.21-02	Medicare 1.45%	\$	-
551-2563-491.22-04	NDPERS Pension 5.26%	\$	-
551-2563-491.25-00	Workers Compensation	\$	-
Employee Benefits Total		\$	-

Other Services			
551-2563-491.33-80	Security Services	\$	-
551-2563-491.34-15	Computer Services	\$	-
551-2563-491.34-36	Credit Card Fees	\$	-
551-2563-491.41-05	Water and Sewer	\$	-
551-2563-491.42-05	Custodial Services	\$	-
551-2563-491.42-10	Grounds Maint. Services	\$	-
551-2563-491.42-15	Garbage Pickup	\$	-
551-2563-491.42-20	Snow Clearing	\$	-
551-2563-491.42-21	Snow Hauling	\$	-
Other Services Total		\$	-

Repairs & Maintenance			
551-2563-491.43-10	Building Repairs	\$	-
551-2563-491.43-20	General Equipment Repair	\$	-
551-2563-491.43-50	Maintenance Service Cont.	\$	-
551-2563-491.43-90	Other Repairs	\$	-
Repairs & Maintenance Total		\$	-

Insurance			
551-2563-491.52-10	Property Insurance	\$	-
551-2563-491.52-30	General Liability	\$	-
Insurance Total		\$	-

Communications

551-2563-491.53-20	Cellular Phone Service	\$	-
Communications Total		\$	-

Travel

551-2563-491.57-60	Out of State Travel Exp	\$	-
Travel Total		\$	-

General Supplies

551-2563-491.61-10	Office Supplies	\$	-
551-2563-491.61-15	Farebox Cards	\$	-
551-2563-491.61-40	General Supplies	\$	-
General Supplies Total		\$	-

Energy

551-2563-491.62-50	Natural Gas	\$	-
551-2563-491.62-51	Electricity	\$	-
Energy Total		\$	-

Miscellaneous

551-2563-491.68-10	Miscellaneous	\$	-
551-2563-491.68-50	Safety Compliance	\$	-
Miscellaneous Total		\$	-

Bad Debt

551-2563-491.68-10	Bad Debt	\$	-
Miscellaneous Total		\$	-

DIV 63 Ground Transport Terminal Total	\$	-
---	-----------	----------

DIV 64 Transit Planning

Account Number **Account Description**

Salaries

551-2564-491.11-00	Full Time Staff	\$	43,704.00
		Salaries Total	\$ 43,704.00

Employee Benefits

551-2564-491.20-01	Health Insurance	\$	11,253.00
551-2564-491.20-03	Dental Insurance	\$	305.00
551-2564-491.20-04	Long Term Disability	\$	99.00
551-2564-491.21-01	FICA 6.2%	\$	2,323.00
551-2564-491.21-02	Medicare 1.45%	\$	543.00
551-2564-491.22-04	NDPERS Pension 5.26%	\$	4,047.00
		Employee Benefits Total	\$ 18,570.00

Other Services

551-2564-491.33-15	Planning Services	\$	24,100.00
		Other Services Total	\$ 24,100.00

DIV 64 Transit Planning Total	\$	86,374.00
--------------------------------------	-----------	------------------

DIV 65 Vehicle Preventative Maintenance

Account Number	Account Description	
Salaries		
551-2565-491.11-00	Full Time Staff	\$ 1,095,383.00
551-2565-491.11-01	Full Time - Overtime	\$ 4,888.00
551-2565-491.11-02	Full Time Banked Sick	\$ 1,425.00
551-2565-491.13-00	Part Time with Benefits	\$ 44,591.00
551-2565-491.14-00	Temporary/Seasonal	\$ 19,968.00
Salaries Total		\$ 1,166,255.00

Employee Benefits		
551-2565-491.20-01	Health Insurance	\$ 294,096.00
551-2565-491.20-03	Dental Insurance	\$ 10,384.00
551-2565-491.20-04	Long Term Disability	\$ 2,870.00
551-2565-491.20-05	Auto Allowance	\$ -
551-2565-491.21-01	FICA 6.2%	\$ 81,219.00
551-2565-491.21-02	Medicare 1.45%	\$ 18,995.00
551-2565-491.22-01	City Pension	\$ 5,157.00
551-2565-491.22-04	NDPERS Pension 5.26%	\$ 121,261.00
551-2565-491.22-05	NDPERS/City Pension .88%	\$ 1,618.00
551-2565-491.22-06	Actuarial Contribution	\$ -
551-2565-491.22-10	NDPERS DC Required Contribu	\$ -
551-2565-491.22-11	NDPERS DC Add'l Contributor	\$ -
551-2565-491.25-00	Workers Compensation	\$ -
Employee Benefits Total		\$ 535,600.00

Other Services		
551-2565-491.33-03	Overhead Cost Allocation	\$ -
551-2565-491.33-71	Other Services Temp Personne	\$ -
551-2565-491.33-80	Security Services	\$ -
551-2565-491.33-86	Bus Driver Services	\$ -
551-2565-491.34-15	Computer Services	\$ -
551-2565-491.34-20	Marketing/ Public Relat.	\$ -
551-2565-491.34-36	Credit Card Fees	\$ -
551-2565-491.38-99	Other Services	\$ -
551-2565-491.42-06	Cleaning Service Contract	\$ -
551-2565-491.42-20	Snow Clearing	\$ -
Other Services Total		\$ -

Repairs & Maintenance		
551-2565-491.43-10	Building Repairs	\$ -
551-2565-491.43-20	General Equipment Repair	\$ 15,000.00
551-2565-491.43-25	Bus Repairs/Parts	\$ 690,000.00
551-2565-491.43-30	Outside Mechanic Service	\$ 295,500.00
Repairs & Maintenance Total		\$ 1,000,500.00

Insurance		
551-2565-491.52-10	Property Insurance	\$ -
551-2565-491.52-20	Automobile Liability	\$ -
551-2565-491.52-30	General Liability	\$ -
Insurance Total		\$ -

Communications		
551-2565-491.53-20	Cellular Phone Service	\$ -
551-2565-491.53-30	Radio Systems	\$ -
551-2565-491.53-60	Other Communications	\$ -
Communications Total		\$ -

Advertising & Printing

551-2565-491.54-10	Legal Publications	\$	-
551-2565-491.55-10	Custom Printed Forms	\$	-
Advertising & Printing Total		\$	-

Travel

551-2565-491.56-60	In State Travel Expenses	\$	-
551-2565-491.57-60	Out of State Travel Exp	\$	-
Travel Total		\$	-

Education

551-2565-491.59-10	Due & Membership Instate	\$	-
551-2565-491.59-11	Dues & Membership Outstate	\$	-
551-2565-491.59-20	Seminar & Conf. Instate	\$	-
551-2565-491.59-21	Seminar & Conf. Outstate	\$	-
Education Total		\$	-

General Supplies

551-2565-491.61-10	Office Supplies	\$	-
551-2565-491.61-30	Vehicle Repair Supplies	\$	19,000.00
551-2565-491.61-41	Small Tools	\$	10,000.00
551-2565-491.61-50	Postage	\$	-
General Supplies Total		\$	29,000.00

Energy

551-2565-491.62-51	Electricity	\$	-
Energy Total		\$	-

Clothing

551-2565-491.64-10	Uniforms	\$	22,000.00
Uniforms Total		\$	22,000.00

Miscellaneous

551-2565-491.68-10	Miscellaneous	\$	-
551-2565-491.68-50	Safety Compliance	\$	-
Miscellaneous Total		\$	-

Bad Debt

551-2565-491.68-10	Bad Debt	\$	-
551-2565-491.80-12	Special Assessment Princ	\$	-
551-2565-491.80-21	Interest on Other Debt	\$	-
Miscellaneous Total		\$	-

Transfer to Other Funds

551-2565-555.90-50	Transfer to Enterprise Funds	\$	-
Uniforms Total		\$	-

/ 65 Vehicle Preventative Maintenance Tc \$ 2,753,355.00

\$ 2,753,355.00

DIV 66 Micro Transit

Account Number	Account Description		
Salaries			
551-2565-491.11-00	Full Time Staff	\$	2,000.00
551-2565-491.11-01	Full Time - Overtime	\$	423.00
551-2565-491.13-00	Part Time with Benefits	\$	-
551-2565-491.14-00	Temporary/Seasonal	\$	767.00
Salaries Total		\$	3,190.00
Employee Benefits			
551-2565-491.20-01	Health Insurance	\$	-
551-2565-491.20-03	Dental Insurance	\$	-
551-2565-491.20-04	Long Term Disability	\$	-
551-2565-491.20-05	Auto Allowance	\$	-
551-2565-491.21-01	FICA 6.2%	\$	198.00
551-2565-491.21-02	Medicare 1.45%	\$	47.00
Salaries Total		\$	245.00
Other Services			
551-2566-491.33-03	Overhead Cost Allocation	\$	14,277.00
551-2566-491.33-86	Bus Driver Services	\$	-
551-2566-491.38-99	Other Services	\$	12,000.00
Other Services Total		\$	26,277.00
Insurance			
551-2566-491.52-20	Automobile Liability	\$	6,600.00
551-2566-491.52-30	General Liability	\$	-
Insurance Total		\$	6,600.00
Communications			
551-2566-491.53-20	Cellular Phone Service	\$	480.00
Communications Total		\$	480.00
Energy			
551-2566-491.62-10	Gasoline	\$	2,200.00
Energy Total		\$	2,200.00
DIV 66 Micro Transit Total		\$	38,992.00

DIV 67 Facility Preventative Maintenance

Account Number	Account Description		
Salaries			
551-2567-491.11-00	Full Time Staff	\$	78,578.00
551-2567-491.11-01	Full Time - Overtime		
551-2567-491.14-00	Temporary/Seasonal	\$	-
Salaries Total			\$ 78,578.00

Employee Benefits			
551-2567-491.20-01	Health Insurance	\$	-
551-2567-491.20-03	Dental Insurance	\$	611.00
551-2567-491.20-04	Long Term Disability	\$	174.00
551-2567-491.20-05	Auto Allowance	\$	-
551-2567-491.21-01	FICA 6.2%	\$	4,872.00
551-2567-491.21-02	Medicare 1.45%	\$	1,139.00
551-2567-491.22-04	NDPERS Pension 5.26%	\$	7,276.00
551-2567-491.22-05	NDPERS/City Pension .88%	\$	-
551-2567-491.22-10	NDPERS DC Required Contrib	\$	-
551-2567-491.22-11	NDPERS DC Add'l Contributic	\$	-
551-2567-491.25-00	Workers Compensation		
Employee Benefits Total			\$ 14,072.00

Other Services			
551-2567-491.33-03	Overhead Cost Allocation	\$	-
551-2567-491.33-71	Other Services Temp Personl	\$	-
551-2567-491.33-80	Security Services	\$	-
551-2567-491.33-86	Bus Driver Services	\$	-
551-2567-491.34-15	Computer Services	\$	-
551-2567-491.34-20	Marketing/ Public Relat.	\$	-
551-2567-491.34-36	Credit Card Fees	\$	-
551-2567-491.38-99	Other Services	\$	-
551-2567-491.34-15	Computer Services	\$	22,000.00
551-2567-491.38-99	Other Services	\$	2,000.00
551-2567-491.41-05	Water and Sewer	\$	20,575.00
551-2567-491.42.05	Custodial Services	\$	108,440.00
551-2567-491.42-10	Grounds Maintenance Svc	\$	5,000.00
551-2567-491.42-15	Garbage Pickup	\$	4,550.00
551-2567-491.42-20	Snow Clearing	\$	26,000.00
551-2567-491.42-21	Snow Hauling	\$	20,500.00
551-2567-491.43-90	Other Repairs	\$	2,000.00
Other Services Total			\$ 211,065.00

Repairs & Maintenance

551-2567-491.43.05	Freight Cost	\$	500.00
551-2567-491.43-10	Building Repairs	\$	60,000.00
551-2567-491.43-20	General Equipment Repair	\$	-
551-2567-491.43-21	Computer Equipment Repair	\$	-
551-2567-491.43-50	Maintenance Service Cont.	\$	1,000.00
Repairs & Maintenance Total			\$ 61,500.00

Rentals

551-2567-491.44-20	Equipment & Vehicle Rent	\$	-
551-2567-491.44-30	Operating Leases	\$	500.00
Rentals Total			\$ 500.00

Insurance

551-2567-491.52-10	Property Insurance	\$	93,455.00
551-2567-491.52-20	Automobile Liability	\$	-
551-2567-491.52-30	General Liability	\$	-
Insurance Total			\$ 93,455.00

Communications

551-2567-491.53-20	Cellular Phone Service	\$	-
551-2567-491.53-30	Radio Systems	\$	-
551-2567-491.53-60	Other Communications	\$	-
Communications Total			\$ -

Advertising & Printing

551-2567-491.54-10	Legal Publications	\$	-
551-2567-491.55-10	Custom Printed Forms	\$	-
Advertising & Printing Total			\$ -

Travel

551-2567-491.56-60	In State Travel Expenses	\$	-
551-2567-491.57-60	Out of State Travel Exp	\$	-
Travel Total			\$ -

Education

551-2567-491.59-10	Due & Membership Instate	\$	-
551-2567-491.59-11	Dues & Membership Outstat	\$	-
551-2567-491.59-20	Seminar & Conf. Instate	\$	-
551-2567-491.59-21	Seminar & Conf. Outstate	\$	-
551-2567-491.59.30	Reference Materials	\$	2,500.00
Education Total			\$ 2,500.00

General Supplies

551-2567-491.61-10	Office Supplies	\$	-
551-2567-491.61-45	Janitorial Supplies	\$	20,000.00
551-2567-491.61-50	Postage	\$	-
General Supplies Total		\$	20,000.00

Energy

551-2567-491.62-10	Gasoline	\$	20,500.00
551-2567-491.62-12	Other Fuels	\$	50,000.00
551-2567-491.62-50	Natural Gas	\$	43,961.00
551-2567-491.62-51	Electricity	\$	66,839.00
551-2567-491.62-52	Propane	\$	500.00
Energy Total		\$	181,800.00

Miscellaneous

551-2567-491.68-10	Miscellaneous	\$	-
551-2567-491.68-50	Safety Compliance	\$	-
Miscellaneous Total		\$	-

Bad Debt

551-2567-491.68-10	Bad Debt	\$	-
551-2567-491.80-12	Special Assessment Princ	\$	-
551-2567-491.80-21	Interest on Other Debt	\$	-
Miscellaneous Total		\$	-

DIV 67 Facility Preventative Maintenance \$ 663,470.00

DIV 68 Mobility Management

Account Number	Account Description		
Salaries			
551-2568-491.11-00	Full Time Staff	\$	100,166.00
551-2568-491.11-02	Full Time Banked Sick	\$	2,859.00
Salaries Total		\$	103,025.00
Employee Benefits			
551-2568-491.20-01	Health Insurance	\$	22,506.00
551-2568-491.20-03	Dental Insurance	\$	611.00
551-2568-491.20-04	Long Term Disability	\$	229.00
551-2568-491.21-01	FICA 6.2%	\$	5,997.00
551-2568-491.21-02	Medicare 1.45%	\$	1,402.00
551-2568-491.22-04	NDPERS Pension 5.26%	\$	9,276.00
551-2568-491.25-00	Workers Compensation	\$	-
Employee Benefits Total		\$	40,021.00
Communications			
551-2568-491.53-20	Cellular Phone Service	\$	550.00
Communications Total		\$	550.00
Advertising & Printing			
551-2568-491.54-11	Marketing	\$	500.00
551-2568-491.55-10	Custom Printed Forms	\$	2,000.00
Advertising & Printing Total		\$	2,500.00
Travel			
551-2568-491.56-60	In State Travel Expenses	\$	750.00
551-2568-491.57-60	Out of State Travel Exp	\$	1,250.00
Travel Total		\$	2,000.00
Education			
551-2568-491.59-12	Dues & Membership	\$	500.00
551-2568-491.59-20	Seminar & Conf. Instate	\$	100.00
Education Total		\$	600.00
General Supplies			
551-2568-491.61-10	Office Supplies	\$	-
551-2568-491.61-50	Postage	\$	-
General Supplies Total		\$	-
DIV 68 Mobility Management Total		\$	148,696.00

DIV 69 Transit Maintce Facility

Account Number	Account Description		
Salaries			
551-2569-491.11-00	Full Time Staff	\$	-
551-2569-491.11-01	Full Time - Overtime	\$	-
551-2569-491.11-02	Full Time Banked Sick	\$	-
551-2569-491.13-00	Part Time W/ Benefits	\$	-
551-2569-491.13-01	Part Time W/ Benefits - Overtime	\$	-
551-2569-491.14-00	Temporary/Seasonal	\$	-
551-2569-491.14-01	Temporary/Seasonal - Overtime	\$	-
Salaries Total		\$	-
Employee Benefits			
551-2569-491.20-01	Health Insurance	\$	-
551-2569-491.20-03	Dental Insurance	\$	-
551-2569-491.20-04	Long Term Disability	\$	-
551-2569-491.21-01	FICA 6.2%	\$	-
551-2569-491.21-02	Medicare 1.45%	\$	-
551-2569-491.22-01	City Pension 5.5%	\$	-
551-2569-491.22-04	NDPERS Pension 5.26%	\$	-
551-2569-491.22-05	NDPERS/City Pension .88%	\$	-
551-2569-491.22-06	Actuarial Contributions	\$	-
551-2569-491.24-00	Unemployment Compensation	\$	-
551-2569-491.25-00	Workers Compensation	\$	-
Employee Benefits Total		\$	-
Other Services			
551-2569-491.34-15	Computer Services	\$	-
551-2569-491.38-99	Other Services	\$	-
551-2569-491.41-05	Water and Sewer	\$	-
551-2569-491.42-05	Custodial Services	\$	-
551-2569-491.42-10	Grounds Maint. Services	\$	-
551-2569-491.42-15	Garbage Pickup	\$	-
551-2569-491.42-21	Snow Hauling	\$	-
Other Services Total		\$	-

Repairs & Maintenance

551-2569-491.43-05	Freight Cost	\$	-
551-2569-491.43-10	Building Repairs	\$	-
551-2569-491.43-20	General Equipment Repair	\$	-
551-2569-491.43-21	Computer Equipment Repair	\$	-
551-2569-491.43-25	Bus Repairs / Parts	\$	-
551-2569-491.43-30	Outside Mechanic Svc	\$	-
551-2569-491.43-50	Maintenance Service Cont.	\$	-
551-2569-491.43-90	Other Repairs	\$	-
Repairs & Maintenance Total		\$	-

Rentals

551-2569-491.44-20	Equipment & Vehicle Rent	\$	-
551-2569-491.44-30	Operating Leases	\$	-
Rentals Total		\$	-

Insurance

551-2569-491.52-10	Property Insurance	\$	-
Insurance Total		\$	-

Communications

551-2569-491.53-20	Cellular Phone Service	\$	-
551-2569-491.53-30	Radio Systems	\$	-
551-2569-491.53-60	Other Communications	\$	-
Communications Total		\$	-

Advertising & Printing

551-2569-491.54-11	Advertising/Marketing	\$	-
551-2569-491.54-10	Legal Publications	\$	-
551-2569-491.55-10	Custom Printed Forms	\$	-
Advertising & Printing Total		\$	-

Travel

551-2569-491.56-60	In State Travel Expenses	\$	-
551-2569-491.57-60	Out of State Travel Exp	\$	-
Travel Total		\$	-

Education

551-2569-491.59-10	Due & Membership Instate	\$	-
551-2569-491.59-12	Dues & Membership Outstate	\$	-
551-2569-491.59-20	Seminar & Conf. Instate	\$	-
551-2569-491.59-21	Seminar & Conf. Outstate	\$	-
551-2569-491.59-30	Reference Materials	\$	-
Education Total		\$	-

General Supplies

551-2569-491.61-10	Office Supplies	\$	-
551-2569-491.61-30	Vehicle Repair Supplies	\$	-
551-2569-491.61-40	General Supplies	\$	-
551-2569-491.61-41	Small Tools	\$	-
551-2569-491.61-45	Janitorial Supplies	\$	-
551-2561-491.61-50	Postage	\$	-
General Supplies Total		\$	-

Energy

551-2569-491.62-10	Gasoline	\$	-
551-2569-491.62-12	Other Fuels	\$	-
551-2569-491.62-50	Natural Gas	\$	-
551-2569-491.62-51	Electricity	\$	-
551-2569-491.62-52	Propane	\$	-
Energy Total		\$	-

Miscellaneous

551-2569-491.64-10	Uniforms/ Clothing (Shop Uniforms)	\$	-
551-2569-491.64-10	Uniforms/ Clothing (Driver Uniforms)	\$	-
551-2569-491.68-10	Miscellaneous	\$	-
551-2569-491.68-50	Safety Compliance	\$	-
Miscellaneous Total		\$	-

Bad Debt

551-2569-491.69-10	Bad Debt	\$	-
Miscellaneous Total		\$	-

DIV 69 Transit Maintce Facility Total \$ -

Fund 551 Public Transportation Op

Account Number Account Description

337 - Local Government Grants

68 00	Misc. Local Grants	\$	-
Local Government Grants Total		\$	-

343 - Public Transportation

10 01	Line Transit Farebox	\$	299,756.00
10 02	Line Transit Pass Revenue	\$	548,734.00
10 04	Line Transit Advertising	\$	121,115.00
10 06	Line Transit - UPass	\$	106,205.00
20 01	Paratransit Fares	\$	34,560.00
20 02	Paratransit Coupon Books	\$	201,045.00
20 03	Paratransit Other Fees	\$	-
30 02	Concessions & Vending	\$	-
30 03	Farebox Cards	\$	5,670.00
Public Transportation Total		\$	1,317,085.00

351 - Fines

60 01	Fixed Route	\$	-
60 02	Paratransit	\$	-
Fines Total		\$	-

361 - Miscellaneous Revenue

18 01	Fixed Route Ins Proceeds	\$	30,000.00
61 21	Transit Maintce Facility	\$	6,000.00
75 02	PFM Pcard Rebates Transit	\$	15,000.00
85 20	Bench Advertising	\$	5,800.00
99 00	Miscellaneous	\$	1,000.00
Miscellaneous Revenue Total		\$	57,800.00

Local Revenue Total		\$	1,374,885.00
----------------------------	--	-----------	---------------------

Fund 551 Public Transportation Op

334 - State Grants

10 35	State Share FEMA	\$	-
10 36	ND Dept of Emergency Serv	\$	-
10 40	CMAQ Transit Operating	\$	-
10 90	Misc State Grants	\$	-
State Operating Grants Total		\$	-

335 - State Shared Revenues

80-00	State Aid for Transport	\$	618,324.00
80 00	State Aid for Transport	\$	424,000.00
State Shared Revenues Total		\$	1,042,324.00

State Revenue Total	\$ 1,042,324.00
----------------------------	------------------------

2025 TOTAL 5307 APPORTIONMENT		\$ 3,054,746	
		Monthly Amount	\$ 254,562.18
Apportionment Calculation # 1 - Population			
Service Area Population within TMA			
	Population	Area (mi ²)	Population Density
Fargo	125,990	50.77	2,481.6
West Fargo	38,626	14.72	2,624.0
NDSU	0	0.00	#DIV/0!
TOTALS	164,616	65.49	2,513.61
25% of 90.8% of Remaining Apportionment			\$ 693,427
	Fargo		\$ 530,719
	West Fargo		\$ 162,708
Apportionment Calculation # 2 - Population x Density			
	Population	Population Density	Population x Density
Fargo	125,990	2,481.6	312,654,719
West Fargo	38,626	2,624.0	101,356,513
Total			414,011,233
25% of 90.8% of Remaining Apportionment			\$ 693,427
	Fargo		\$ 523,665
	West Fargo		\$ 169,762
Apportionment Calculation # 3 - Bus Revenue Miles			
50% of 90.8% of Remaining Apportionment			\$ 1,386,855
<i>Fargo Revenue Miles</i>	733,696	85.66%	\$ 1,188,014
<i>West Fargo Revenue Miles</i>	40,632	4.74%	\$ 65,793
<i>NDSU Revenue Miles</i>	82,168	9.59%	\$ 133,048
	856,496		
Apportionment Calculation # 4 - Bus Incentive			
9.2% of Remaining Apportionment			\$ 281,037
Bus Passenger Miles x Bus Passenger Miles/Operating Expenses			
<i>Fargo Passenger Miles</i>	2,721,598	<i>Fargo Operating Expenses</i>	8,014,690.88
<i>West Fargo Passenger Miles</i>	207,832	<i>West Fargo Operating Expenses</i>	749,656.75
<i>NDSU Passenger Miles</i>	483,233	<i>NDSU Operating Expenses</i>	898,641.34
	3,412,663		9,662,988.97
Fargo	74.43%	\$	209,180
West Fargo	4.64%	\$	13,041
NDSU	20.93%	\$	58,815

5310 Allocation	\$	241,922.28	
Total Project	\$	302,402.85	
Mobility Management	\$	148,696.00	
Remaing 5310 Funds	\$	153,706.85	Capital
Local Share of Remaining		\$30,741	Capital

5310 - Mobility Manager	
1156-2025-2	
MM Salary	119,141.00
Monthly	9,928.42

	Revenue Hours	%	Share
Fargo Fixed	55,834.66	46.09%	14,167.49
Moorhead/Dilworth Fixed	33,707.00	27.82%	8,552.82
West Fargo Fixed	2,473.34	2.04%	627.59
Fargo Para	18,923.00	15.62%	4,801.52
Moorhead/Dilworth Para	5,350.00	4.42%	1,357.51
West Fargo Para	4,865.00	4.02%	1,234.45
	<u>121,153.00</u>	<u>100.00%</u>	<u>30,741.37</u>

Item Title: Request for security upgrades to City courtroom

Presented By: Captain Derek Cruff

Requested Action/Staff Recommendation: Approval of funding to update security measures in the City's courtroom as requested by staff.

Background & Project Summary:

The current building and courtroom were built with a dual purpose in mind, previously serving as both a public commission room and a courtroom. Security was not a key concept that was addressed for the space at that time. As the City continues to grow, the number of citizens visiting the courtroom has also increased exponentially as seen in the following:

- 2022 Total Criminal Cases: 3,274
- 2023 Total Criminal Cases: 3,368
- 2024 Total Criminal Cases: 4,125
- 2025 (Projected) Total Criminal Cases: 4,266

The number of individuals served by the courtroom has increased by 30% over the past four years and is expected to continue to grow alongside the City.

Municipal Court is currently held two days a week from 12:30 p.m. to the end of the business day, serving 65-75 people a week. In addition, the Municipal Court hosts status hearings and ITV virtual court. There is a notable increase in foot traffic throughout the halls when court is held.

Many of the individuals seen in court have other felony cases pending and are appearing at the municipal level for misdemeanor cases.

The needs for a dual-purpose courtroom have changed over time due to the growth of the city and the growing needs of the court system. Currently, the only physical security is the retractable turn buckles to keep defendants back from the judge and staff.

During the court process, staff are walking back and forth in the aisle directly next to defendants who are being processed through the system. The current layout provides little to no safety for staff and the judge, giving it a D or less rating for safety.

The requested funds will be used to install additional safety measures as proposed:

1. Move away from a dual-purpose layout to a traditional courtroom setting

West Fargo City Commission

Bernie Dardis, Commission President

Brad Olson, Commission Vice President

Roben Anderson, Rory Jorgensen, Amy Zundel, Commissioners

Dustin Scott, City Administrator

2. Install a 36-inch barrier wall across the front of the room with a 42-inch wide swinging door entrance to the formal court area. This creates real division between the two areas that clearly defines the spaces.
3. Install a 46-inch barrier wall that goes up the ramp to the judge's bench. This will continue down the side to enclose the door entrance to the courtroom from the clerk's secure office.
4. The barrier wall will have a glass topper installed to 20 inches in height to add security that will not allow for physical contact with court staff. This will not cause any issues with the building's previous heating and cooling systems.
5. Install a formal witness stand, raising up the floor in the cove that exists next to the ramp. The wall front will be continued around to partially enclose the area, adding a countertop for the microphone and exhibits to be viewed from as testimony occurs.

Bringing the courtroom security up to these standards by following a more traditional model will increase our security level to an A and make it easier for officers assigned to security duties to maintain a safe environment for all parties.

Attached Supporting Documents:

- DakBUILT West Fargo Courtroom Proposal
- Initial Floor Plan
- Photo of current courtroom
- 3-D Rendering

Financial Impact:

The proposal costs, including all materials and installation, will be \$44,213.53



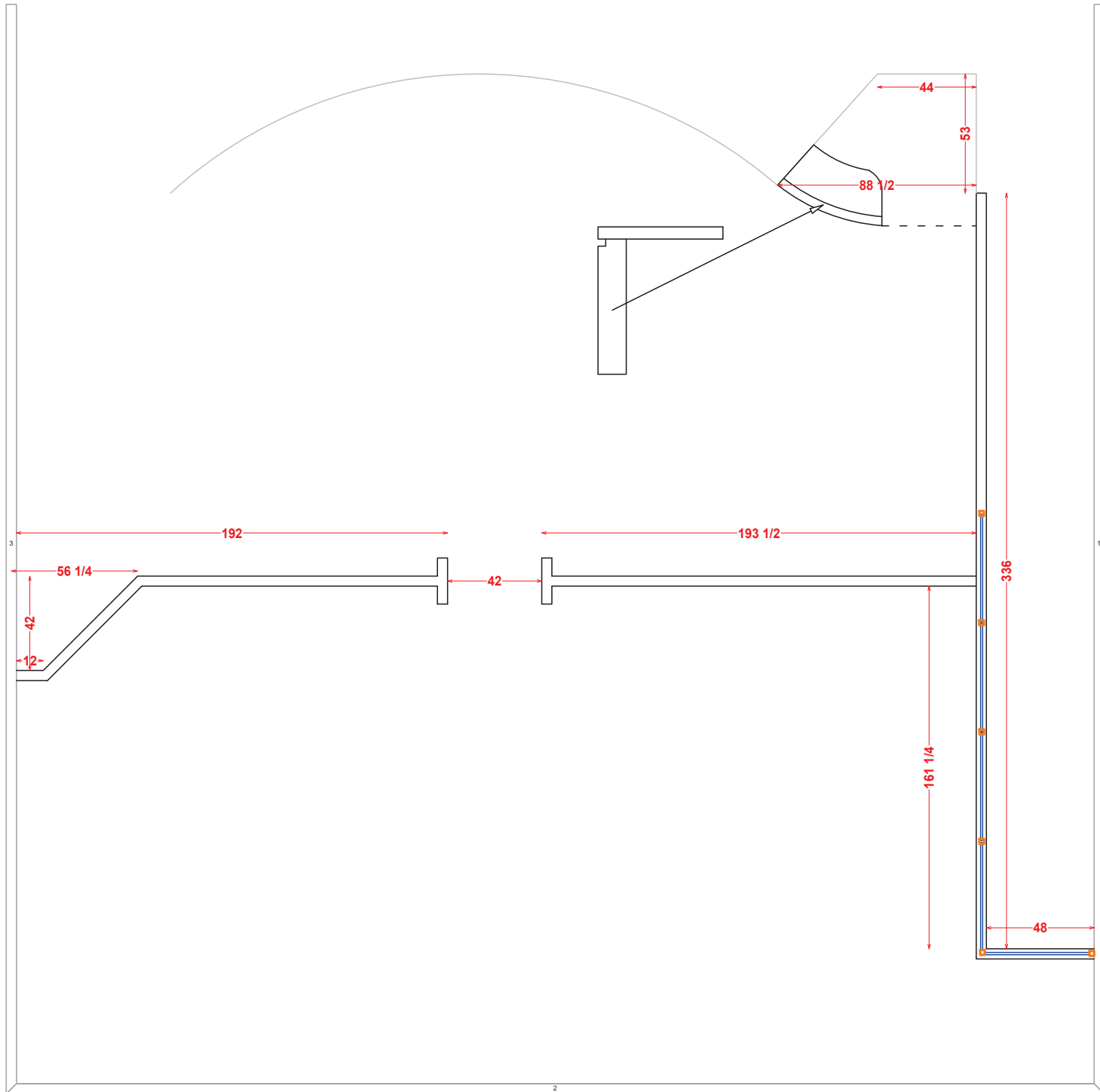

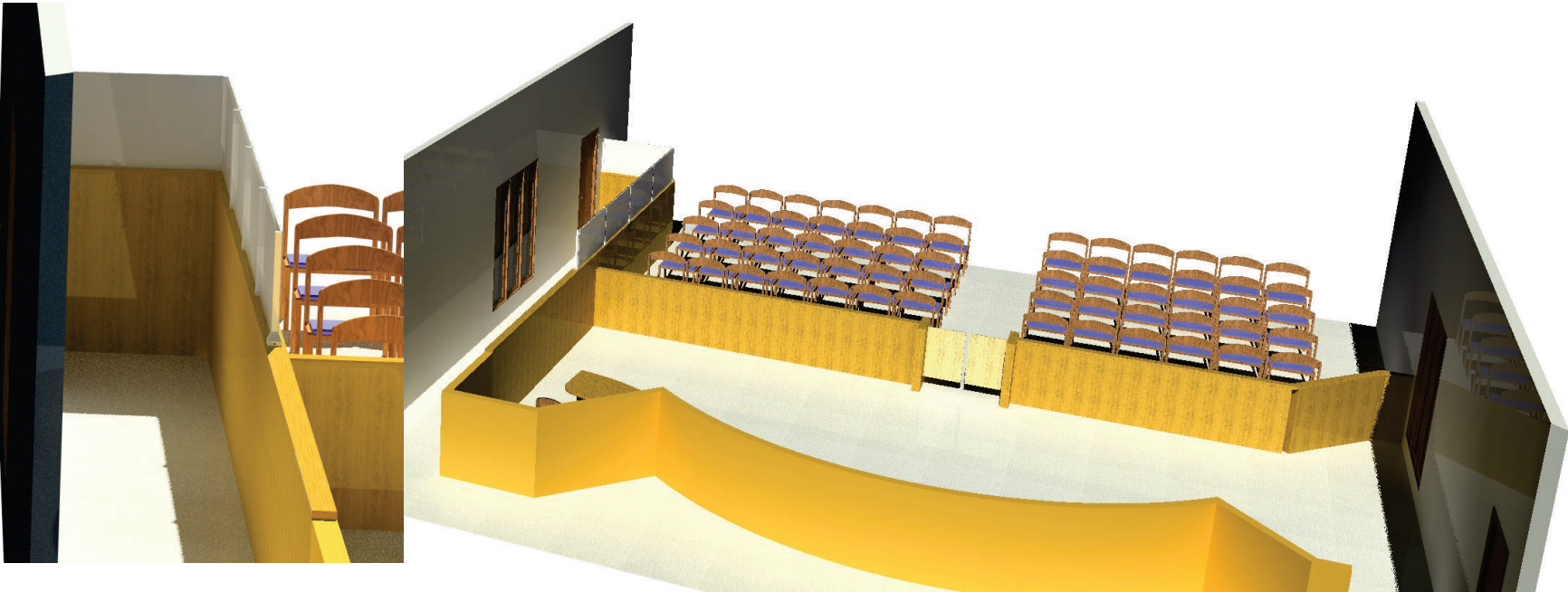

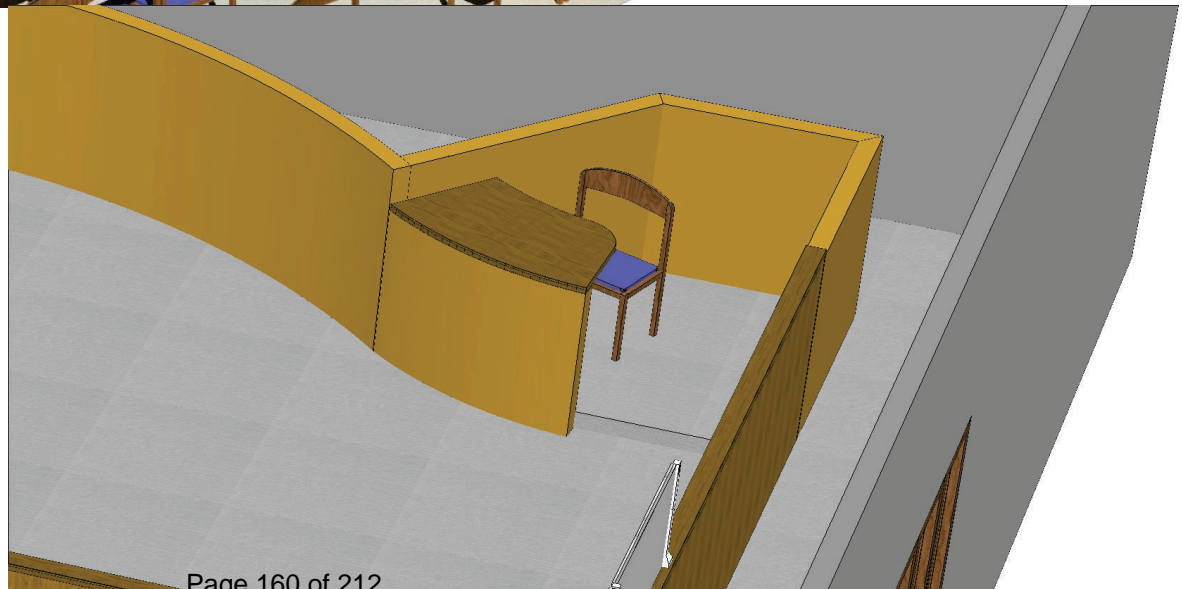



To: West Fargo City Commission
From: Haider Howitzer- IT Director
Date: December 15th 2025
Subject: Building Security Camera System and Door Access Improvements
Action: Approve IT to Proceed with Security Camera and Door Access Improvements

Commission President

Bernie Dardis

Primary Portfolio:
Administrative Services

Secondary Portfolio:
Police & Fire

Commission Vice President

Brad Olson

Primary Portfolio:
Police & Fire

Secondary Portfolio:
Street, Water & Sewer

Commissioner

Roben Anderson

Primary Portfolio:
Community & Development Services

Secondary Portfolio:
Administrative Services

Commissioner

Amy Zundel

Primary Portfolio:
Street, Water & Sewer

Secondary Portfolio:
Sanitation

Commissioner

Rory Jorgensen

Primary Portfolio:
Sanitation

Secondary Portfolio:
Community & Development Services

City Administrator

Dustin T. Scott

Summary and Recommendation:

This is the final project in a three-year plan to replace all the city's obsolete IT infrastructure.

The current security camera and door access systems across all city buildings are outdated and increasingly costly to maintain. Each year there are expenses recognized to repair, patch and maintain these systems.

This proposed improvement will replace the current outdated systems with a modern, integrated solution using Genetec, which combines video surveillance and access control into a single platform.

These improvements will dramatically increase the reliability of access to our facilities, and the new system is scalable and modular. By installing these updates, our system will be more reliable and will ensure long-term flexibility as the city's needs evolve.

In preparation for this project, we reached out to ETSystems and Highpoint Networks who are vendors that we have a relationship with and are State approved vendors to get an idea of what we can anticipate these projects to cost. The amount that they said to expect would be in the \$450,000 to \$500,000 range, combined for both projects.

With the amount of the anticipated costs approaching \$250,000 for each of these projects, to follow Century Code for the competitive bidding process, the intent is to solicit proposals from vendors to complete each project via a Request for Proposals (RFP) process.

We have consulted with Legal and each of these projects, the security camera system and the door access improvements are considered exclusive to each other and not considered one overall project.

Policy Analysis:

To provide modern, modular, secure access and reliable monitoring for city infrastructure.

Financial Analysis:

This project was included in the 2024 Capital Improvement Plan in the amount of \$516,500 and it is proposed to be paid utilizing Capital Improvement Sales Tax.

Process	Action
First Reading	Approved by a 3-2 vote Sept. 1, 2020.
Second Reading	
Approval	



“Consent” or “Regular” Agenda Item?
[Regular]

To: West Fargo City Commission
From: Jerry Wallace, City Engineer
Date: December 15, 2025
Subject: Improvement District no. 2297 – South Pond Neighborhood Pavement Rehabilitation
Action: Conduct the Determination of Protest Sufficiency and Approve Associated Resolution

Commission President

Bernie Dardis
Primary Portfolio:
 Administrative Services
Secondary Portfolio:
 Police & Fire

Commission Vice President

Brad Olson
Primary Portfolio:
 Police & Fire
Secondary Portfolio:
 Street, Water & Sewer

Commissioner

Roben Anderson
Primary Portfolio:
 Community & Development Services
Secondary Portfolio:
 Administrative Services

Commissioner

Rory Jorgensen
Primary Portfolio:
 Sanitation
Secondary Portfolio:
 Community & Development Services

Commissioner

Amy Zundel
Primary Portfolio:
 Street, Water & Sewer
Secondary Portfolio:
 Sanitation

City Administrator

Dustin T. Scott

New Information and Recommendation:

At the November 3rd Commission meeting, a Resolution of Necessity was approved for the above-referenced project. All properties within the Improvement District received a letter informing them of the project and instructing them how to file a written protest against the resolution’s adoption.

At the time of preparing this agenda item, staff have received one letter in protest to a future special assessment.

The following documents are attached for review/consideration:

- Affidavit of Publication, which was published on Wednesday, November 12, 2025, and Wednesday, November 19, 2025, in the Fargo Forum.
- Mailing that was sent to property owners within the proposed Improvement District, which was mailed Thursday, November 6, 2025, and consisted of a Notice of Potential Assessed Improvements Impacting Your Property along with an Improvement District Map.
- Resolution of Insufficient Protests.

Staff Recommendation: Conduct the Determination of Protest Sufficiency and Approve Associated Resolution

Background and Project Summary:

This project is intended to improve pavement condition and ride quality and extend the lifespan of the roadways within the district. The project involves the rehabilitation of existing asphalt roadways through a mill-and-overlay process. This will restore pavement condition and ride quality while extending service life. ADA curb ramps will also be upgraded where needed. The project is consistent with the City’s pavement management policy, which recommends resurfacing approximately every 10–15 years based on observed pavement conditions.

Policy Analysis:

The Engineering Department’s pavement management policy recommends scheduling rehabilitation activities when pavement surfaces are approximately 10 to 15 years old, depending on observed condition and performance. Locations for mill-and-overlay improvements are identified through ongoing assessment of pavement condition data and local engineering judgment. The proposed project is consistent with these practices and supports the City’s commitment to proactive infrastructure maintenance. Mill-and-overlay projects are a cost-effective preservation

strategy that enhances pavement performance, extends service life, and reduces the need for more extensive and costly reconstruction in the future.

Financial Analysis:

Consistent with what was presented with the 2024 CIP, this project is intended to have 50% of the total project cost special assessed to the benefiting properties, and 50% paid for via Capital Improvements Sales Tax. The total project cost is estimated to be \$1,517,417.25.

Previously Presented Information and Commission Actions:

November 3, 2025 –

- **Staff Recommendation:** Approve both an Engineer's Report and Task Order, Direct Engineer to prepare Plans and Specifications, and Authorize Resolution of Necessity.
- **Commission Action:** Commissioner Olson moved and Commissioner Zundel seconded to approve. No opposition, motion carried.

August 18, 2025 –

- **Staff Recommendation:** Create Improvement District No. 2296 and Direct Engineer to prepare an Engineer's Report.
- **Commission Action:** Commissioner Olson moved and Commissioner Zundel seconded to approve. No opposition, motion carried.

CITY PROJECT PROCESS FLOW CHART

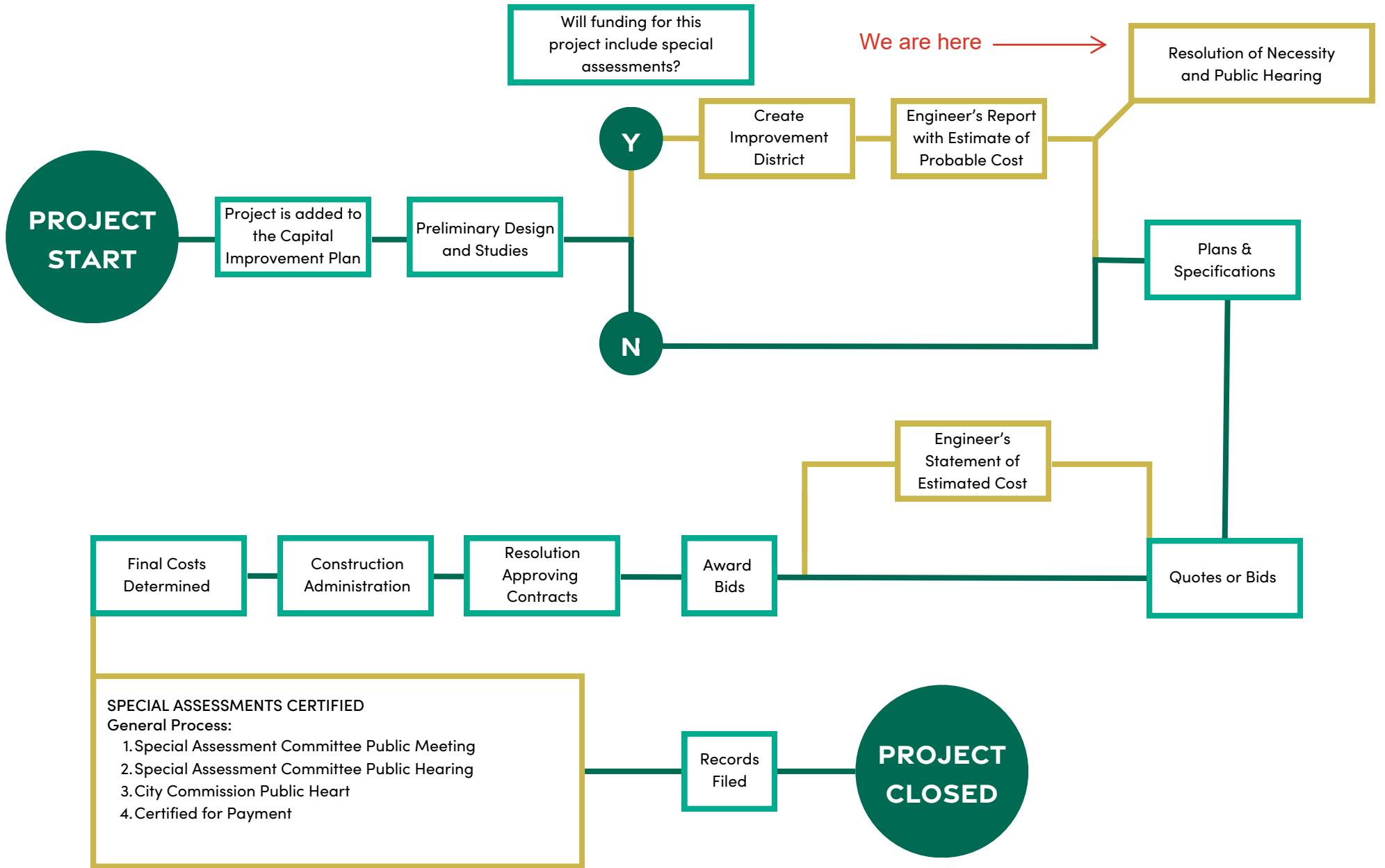

SPECIAL ASSESSMENTS CERTIFIED

General Process:

1. Special Assessment Committee Public Meeting
2. Special Assessment Committee Public Hearing
3. City Commission Public Heart
4. Certified for Payment

*The City of West Fargo creates an Engineer's Report and Estimate of Probably Cost for most projects, but is legally required to do so for projects using special assessment funding.

*Project Steps in YELLOW boxes are only necessary when a project is funding through the use of special assessments.



AFFIDAVIT OF PUBLICATION

State of Florida, County of Orange, ss:

Edmar Corachia, being first duly sworn, deposes and says: That (s)he is a duly authorized signatory of Column Software, PBC and duly authorized agent of the The Forum of Fargo-Moorhead (ND), a newspaper printed and published in the City of Fargo, County of Cass, State of North Dakota.

1. I am the designated agent of The The Forum of Fargo-Moorhead (ND), under the provisions and for the purposes of, Section 31-04-06, NDCC, for the newspaper listed on the attached exhibit.

2. The newspaper listed on the exhibit published the advertisement of: **ND General Public Notice Notice**; (2) time: *Wednesday, November 12, 2025, Wednesday, November 19, 2025*, as required by law or ordinance.

3. All of the listed newspapers are legal newspapers in the State of North Dakota and, under the provisions of Section 46-05-01, NDCC, are qualified to publish any public notice or any matter required by law or ordinance to be printed or published in a newspaper in North Dakota.

Edmar Corachia

(Signed) _____

VERIFICATION

State of Florida
County of Orange

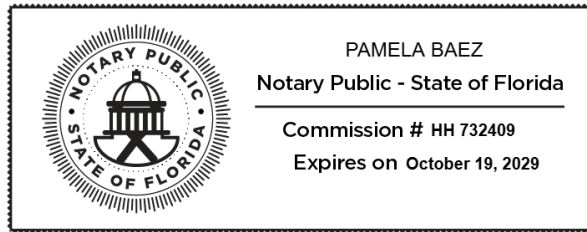

Subscribed in my presence and sworn to before me on this: 11/19/2025

Notary Public

Notarized remotely online using communication technology via Proof.

RESOLUTION DECLARING WORK NECESSARY

BE IT RESOLVED by the Board of City Commissioners of the City of West Fargo, North Dakota that it is hereby found and declared that it is necessary to construct an improvement in and for Improvement District No. 2297 - South Pond Neighborhood Pavement Rehabilitation consisting of partial depth asphalt milling and placement of hot mix asphalt overlay necessary to improve and maintain current roadway and ride quality as well as reconstructing any pedestrian ramps withing the Improvement District that are out of ADA compliance and other appurtenances in connection with the above specified improvements, in accordance with and as described in the resolution creating said district, and the Engineer's Report which has been prepared by the Engineer for the City of West Fargo and approved by this commission which resolution and Engineer's Report together with an estimate of the probable cost of the work, are now on file in the office of the City Auditor and are open to public inspection.

BE IT FURTHER RESOLVED that a portion of the cost of said improvement be specially assessed against the benefited property in said improvement district in amounts proportionate to and not exceeding the benefits to be derived by them respectively from said improvement.

BE IT FURTHER RESOLVED that the owners of the property liable to be specially assessed for said improvements may file written protests against the said improvements within thirty (30) days after first publication of this resolution, and this Board shall at its next meeting after the expiration of said period, to-wit: On the 15th day of December, at 5:30 p.m. meet at the City Commission Chamber in City Hall, 2515 6th St E, West Fargo, for the purpose of hearing and determining the sufficiency of any protests so filed and of taking any such further action with respect to said improvements as may then deemed necessary and expedient.

BE IT FURTHER RESOLVED that the City Auditor is hereby authorized and directed to cause this resolution, including a map of the improvements directed, to be published one each week for two consecutive weeks in The Forum, the official newspaper of the City of West Fargo, North Dakota.

Dated: November 3, 2025
STATE OF NORTH DAKOTA
COUNTY OF CASS

APPROVED:
Bernie Dardis
President of Board of City Commissioners'

ATTEST:
Dustin T. Scott City Auditor

I, Dustin T. Scott, the duly appointed, qualified and acting City Auditor of the City of West Fargo, so hereby certify the foregoing to be a full, true and correct copy of the resolution adopted by the Board of City Commissioners of the City of West Fargo, at the meeting of the board held on the 3rd day of November, 2025 and that such Resolution is now part of the permanent records of the City of West Fargo, as such records are filed in the office of the City Auditor.

IN WITNESS WHEREOF, I have hereunto set my hand this 3rd day of November 2025.

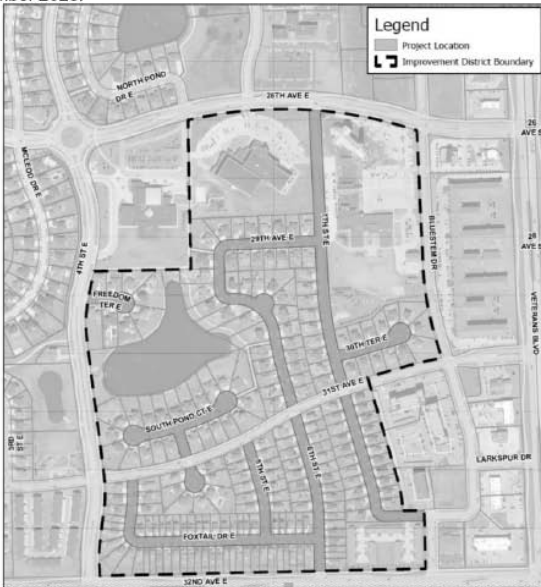

**DEPARTMENT OF
ENGINEERING**



November 6, 2025

██████████
██████████
WEST FARGO, ND 58078

Notice of Hearing: Next Steps for Assessed Improvements Impacting Your Property

Parcel Number: ██████████
Address: ██████████
Improvement District: 2297

Attention Property Owner,

This letter is regarding Improvement District 2297. This project involves milling and overlaying the existing roadways to improve pavement condition, enhance ride quality, and extend the pavement's service life. The district boundary for this future project includes the property you own at the address listed above. The proposed funding sources for this work include 50% of the project costs being paid via City Capital Improvements Sales Tax funds, and 50% being specially assessed to benefitting properties. An improvement district map has been included for your reference.

The current estimated total assessment for your property is \$██████████. Consistent with City policy, the proposed repayment term for this assessment is 25 years.

A "Resolution Declaring Work Necessary" for this improvement district is being published in the legal section of the 11/12/2025 and 11/19/2025 editions of the Fargo Forum as required by NDCC 40-22. This letter is additional courtesy communication from the City of West Fargo.

Property Owners may file a written protest against the creation of a special assessment district to fund this project by 12/13/2025 by 5:00 p.m. Written protests must be sent to city.auditor@westfargond.gov or to City Auditor, 2515 6th Street East, West Fargo, ND 58078.

Written protests must include the following:

1. Name(s) of all owners of the property
2. Address of the property
3. Reference to the Improvement District being protested



A public hearing has been scheduled for the December 15, 2025, City Commission Meeting beginning at 5:30p.m. During this hearing, Commissioners will review filed protests and may take further action on this project.

This is the only mailed notice that the City of West Fargo will provide for this protest opportunity. More information about the special assessments process will be mailed after construction is completed.

Thank you,
City of West Fargo Staff

2515 6th Street E
West Fargo, ND 58078
701-515-5100
engineering@westfargond.gov
westfargond.gov

Legend

-  Project Location
-  Improvement District Boundary

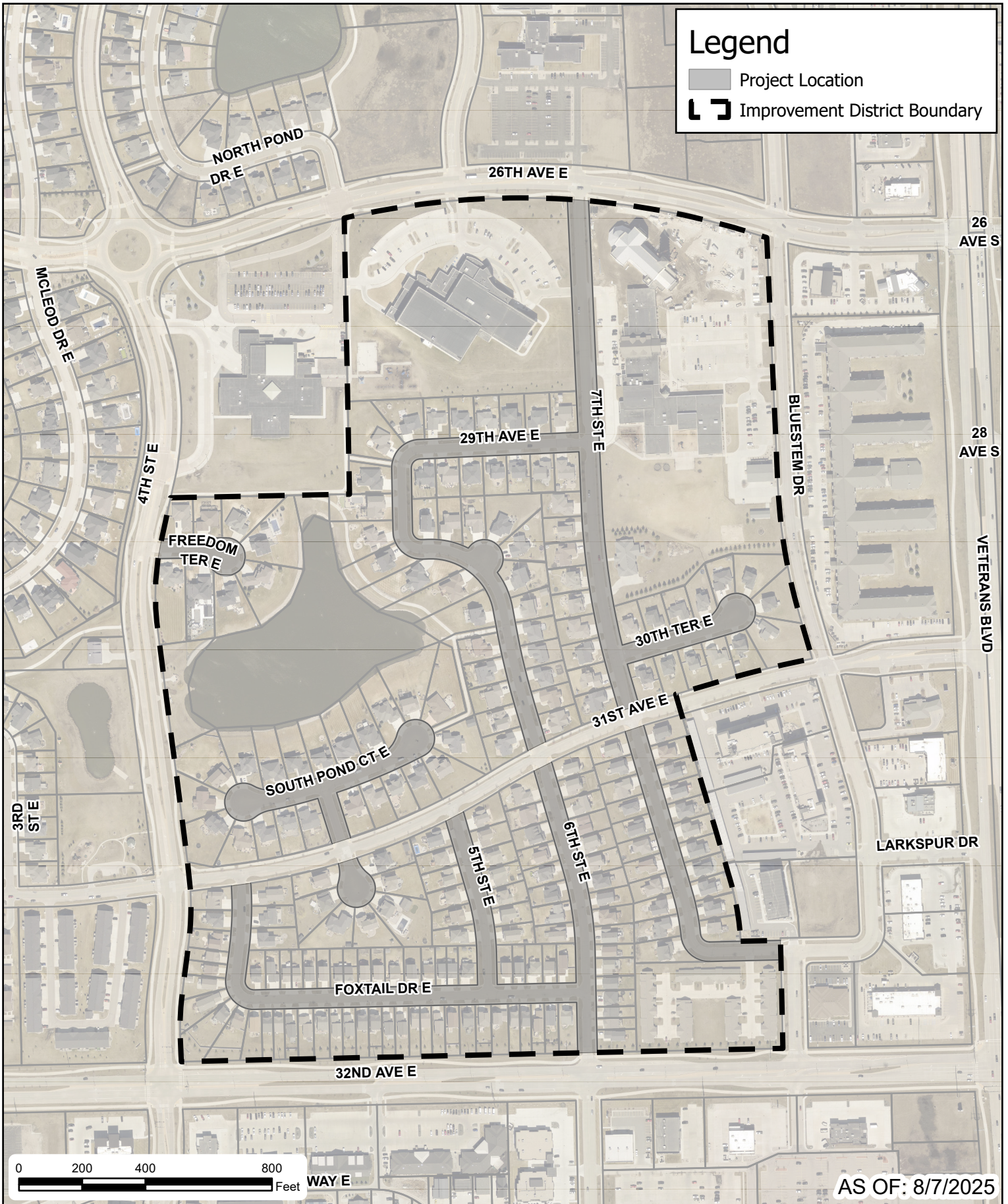

AS OF: 8/7/2025

IMPROVEMENT DISTRICT MAP
IMPROVEMENT DISTRICT NO. 2297
SOUTH POND MILL AND OVERLAY
WEST FARGO, NORTH DAKOTA

Created By: HS/TJS Date Created: 08/07/25 Date Saved: 08/21/25 Date Exported: 08/21/25
 Plotted By: Parcel Date: 08/04/25 Aerial Image: 2023 County NAIP SIDS Elevation Data: Lidar
 Horizontal Datum: NAD 1983 StatePlane North Dakota South FIPS 3302 Feet Vertical Datum: NAVD1988
 Q:\Projects\30000\30600\30628 Dist2297\SouthPondMillOverlay\GIS\APRX\30628_ProjectMaps.aprx

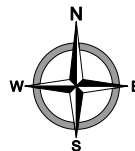

moore
 engineering, inc.

Commissioner _____ introduced the following Resolution and moved its adoption:

**RESOLUTION DETERMINING THAT INSUFFICIENT PROTESTS WERE FILED ON
IMPROVEMENTS IN IMPROVEMENT DISTRICT NO. 2297 – SOUTH POND NEIGHBORHOOD
PAVEMENT REHABILITATION**

BE IT RESOLVED by the Board of City Commissioners of the City of West Fargo, North Dakota, that said Board of City Commissioners has heretofore by Resolution determined and declared it necessary to construct an improvement in Improvement District No. 2297 – South Pond Neighborhood Pavement Rehabilitation of the City of West Fargo, consisting of partial depth asphalt milling and placement of hot mix asphalt overlay necessary to improve and maintain current roadway and ride quality as well as reconstructing any pedestrian ramps within the Improvement District that are out of ADA compliance and other appurtenances in connection with the above specified improvements and that said Resolution has been duly published as required by law, and that not less than thirty days have expired since the first publication thereof, and the opportunity having been afforded as provided by law for the property owners liable to be specially assessed for said improvement to file protests against the making thereof, and this Board having duly met to consider all protests so filed, and being fully advised in the premises, it is hereby determined that no protests were filed within the time and manner provided by law against the making of said improvement; therefore, the Board of City Commissioners and this City are authorized to proceed with the construction of the same and to pay the cost thereof by the levy of special assessments.

Dated: December 15, 2025

APPROVED:

President of Board of City Commissioners

ATTEST:

City Auditor

The motion for the adoption of the foregoing resolution was duly seconded by **Commissioner** _____. On roll call vote, the following commissioners voted aye: _____ The following commissioners voted nay: _____ the following commissioners were absent and not voting: _____ the majority having voted aye, the motion carried and the resolution was duly adopted.



“Consent” or “Regular” Agenda Item?
[Regular]

To: West Fargo City Commission
From: Jerry Wallace, City Engineer
Date: December 15, 2025
Subject: Improvement District No. 2296 – Shadow Wood Neighborhood Pavement Rehabilitation
Action: Conduct the Determination of Protest Sufficiency and Approve Associated Resolution

Commission President

Bernie Dardis
Primary Portfolio:
 Administrative Services
Secondary Portfolio:
 Police & Fire

Commission Vice President

Brad Olson
Primary Portfolio:
 Police & Fire
Secondary Portfolio:
 Street, Water & Sewer

Commissioner

Roben Anderson
Primary Portfolio:
 Community & Development Services
Secondary Portfolio:
 Administrative Services

Commissioner

Rory Jorgensen
Primary Portfolio:
 Sanitation
Secondary Portfolio:
 Community & Development Services

Commissioner

Amy Zundel
Primary Portfolio:
 Street, Water & Sewer
Secondary Portfolio:
 Sanitation

City Administrator

Dustin T. Scott

New Information and Recommendation:

At the November 3rd City Commission meeting, a Resolution of Necessity was approved for the above-referenced project. All properties within the Improvement District received a letter informing them of the project and instructing them on how to file a written protest against the resolution's adoption.

At the time of preparing this agenda item, staff have received one letter arguing against assessed improvements.

The following documents are attached for review/consideration:

- Affidavit of Publication, which was published on Wednesday, November 12th, 2025 and Wednesday, November 19th, 2025, in the Fargo Forum.
- Mailing that was sent to property owners within the proposed Improvement District, which was mailed on November 6th, 2025 and included a Notice of Potential Assessed Improvements Impacting Your Property along with an Improvement District Map.
- Resolution of Insufficient Protests.

Staff Recommendation: Conduct the Determination of Protest Sufficiency and Approve Associated Resolution.

Background and Project Summary:

This project is intended to improve pavement condition and ride quality and extend the lifespan of the roadways within the district. The project involves the rehabilitation of existing asphalt roadways through a mill-and-overlay process. This will restore pavement condition and ride quality while extending service life. ADA curb ramps will also be upgraded where needed. The project is consistent with the City's pavement management policy, which recommends resurfacing approximately every 10–15 years based on observed pavement conditions.

Policy Analysis:

The Engineering Department's pavement management policy recommends scheduling rehabilitation activities when pavement surfaces are approximately 10 to 15 years old, depending on observed condition and performance. Locations for mill-and-overlay improvements are identified through ongoing assessment of pavement condition data and local engineering judgment. The proposed project is consistent with these practices and supports the City's commitment to proactive infrastructure

maintenance. Mill-and-overlay projects are a cost-effective preservation strategy that enhances pavement performance, extends service life, and reduces the need for more extensive and costly reconstruction in the future.

Financial Analysis:

Consistent with what was presented with the 2024 CIP, this project is intended to have 50% of the total project cost special assessed to the benefiting properties, and 50% paid for via Capital Improvements Sales Tax. The total estimated cost is \$1,758,686.25.

Previously Presented Information and Commission Actions:

November 3, 2025 –

- **Staff Recommendation:** Approve both an Engineer's Report and Task Order, Direct Engineer to prepare Plans and Specifications, and Authorize Resolution of Necessity.
- **Commission Action:** Commissioner Jorgensen moved and Commissioner Anderson seconded to approve. No opposition, motion carried.

August 18, 2025 –

- **Staff Recommendation:** Create Improvement District No. 2296 and Direct Engineer to prepare an Engineer's Report.
- **Commission Action:** Commissioner Olson moved and Commissioner Zundel seconded to approve. No opposition, motion carried.

CITY PROJECT PROCESS FLOW CHART

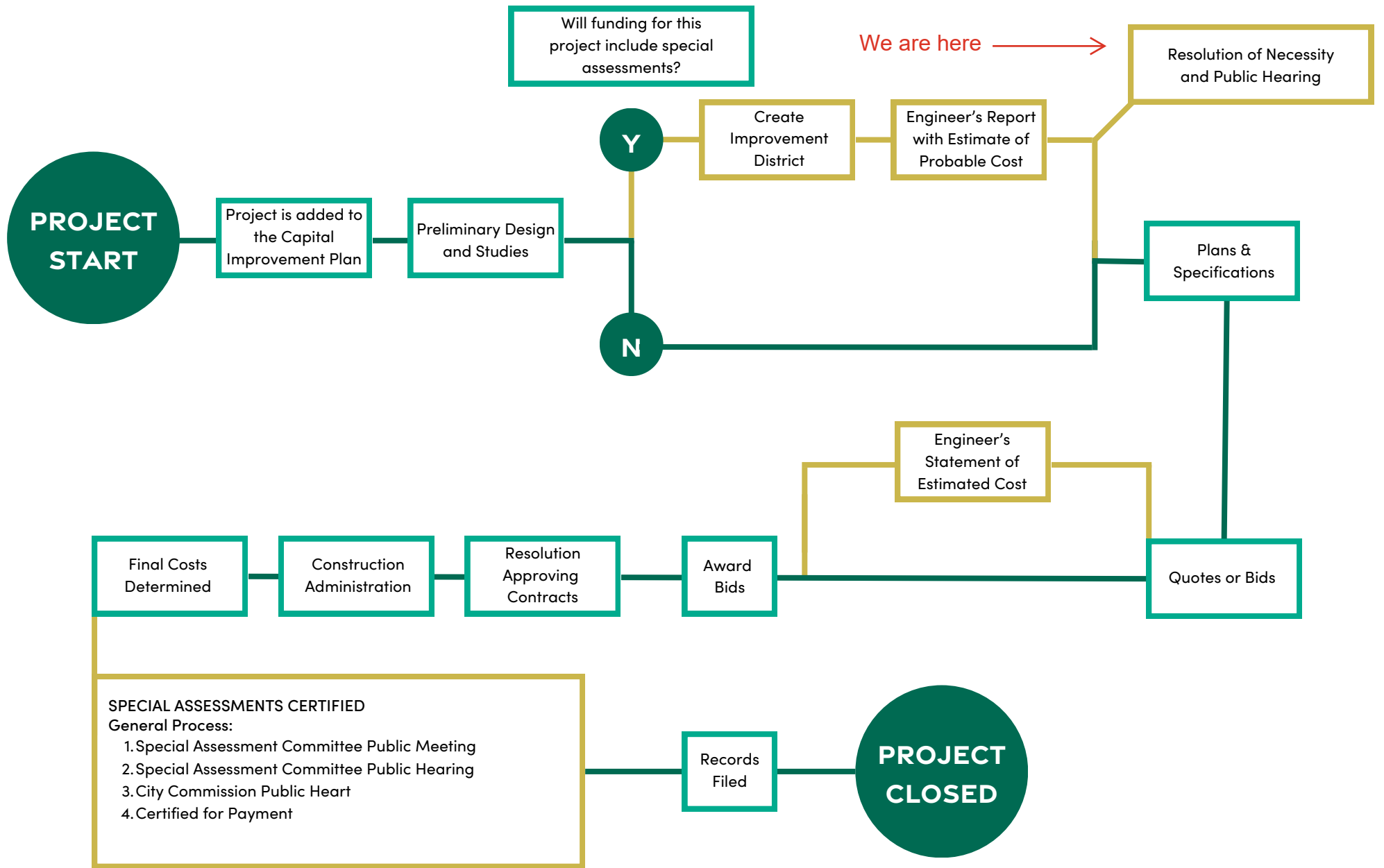

SPECIAL ASSESSMENTS CERTIFIED

General Process:

1. Special Assessment Committee Public Meeting
2. Special Assessment Committee Public Hearing
3. City Commission Public Heart
4. Certified for Payment

*The City of West Fargo creates an Engineer's Report and Estimate of Probably Cost for most projects, but is legally required to do so for projects using special assessment funding.

*Project Steps in YELLOW boxes are only necessary when a project is funding through the use of special assessments.



AFFIDAVIT OF PUBLICATION

State of Florida, County of Orange, ss:

Edmar Corachia, being first duly sworn, deposes and says: That (s)he is a duly authorized signatory of Column Software, PBC and duly authorized agent of the The Forum of Fargo-Moorhead (ND), a newspaper printed and published in the City of Fargo, County of Cass, State of North Dakota.

1. I am the designated agent of The The Forum of Fargo-Moorhead (ND), under the provisions and for the purposes of, Section 31-04-06, NDCC, for the newspaper listed on the attached exhibit.

2. The newspaper listed on the exhibit published the advertisement of: **ND General Public Notice Notice**; (2) time: *Wednesday, November 12, 2025, Wednesday, November 19, 2025*, as required by law or ordinance.

3. All of the listed newspapers are legal newspapers in the State of North Dakota and, under the provisions of Section 46-05-01, NDCC, are qualified to publish any public notice or any matter required by law or ordinance to be printed or published in a newspaper in North Dakota.

Edmar Corachia

(Signed) _____

VERIFICATION

State of Florida
County of Orange

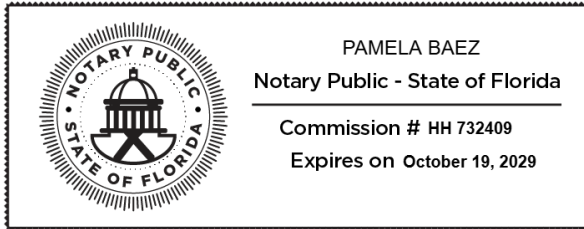

Subscribed in my presence and sworn to before me on this: 11/19/2025

Notary Public

Notarized remotely online using communication technology via Proof.

RESOLUTION DECLARING WORK NECESSARY

BE IT RESOLVED by the Board of City Commissioners of the City of West Fargo, North Dakota that it is hereby found and declared that it is necessary to construct an improvement in and for Improvement District No. 2296 - Shadow Wood Neighborhood Pavement Rehabilitation consisting of partial depth asphalt milling and placement of hot mix asphalt overlay necessary to improve and maintain current roadway and ride quality as well as reconstructing any pedestrian ramps within the Improvement District that are out of ADA compliance and other appurtenances in connection with the above specified improvements, in accordance with and as described in the resolution creating said district, and the Engineer's Report which has been prepared by the Engineer for the City of West Fargo and approved by this commission which resolution and Engineer's Report together with an estimate of the probable cost of the work, are now on file in the office of the City Auditor and are open to public inspection.

BE IT FURTHER RESOLVED that a portion of the cost of said improvement be specially assessed against the benefited property in said improvement district in amounts proportionate to and not exceeding the benefits to be derived by them respectively from said improvement.

BE IT FURTHER RESOLVED that the owners of the property liable to be specially assessed for said improvements may file written protests against the said improvements within thirty (30) days after first publication of this resolution, and this Board shall at its next meeting after the expiration of said period, to-wit: On the 15th day of December, at 5:30 p.m. meet at the City Commission Chamber in City Hall, 2515 6th St E, West Fargo, for the purpose of hearing and determining the sufficiency of any protests so filed and of taking any such further action with respect to said improvements as may then deemed necessary and expedient.

BE IT FURTHER RESOLVED that the City Auditor is hereby authorized and directed to cause this resolution, including a map of the improvements directed, to be published one each week for two consecutive weeks in The Forum, the official newspaper of the City of West Fargo, North Dakota.

Dated: November 3, 2025

APPROVED:
Bernie Dardis
President of Board of City Commissioners

ATTEST:
Dustin T. Scott City Auditor

STATE OF NORTH DAKOTA
COUNTY OF CASS ss.

I, Dustin T. Scott, the duly appointed, qualified and acting City Auditor of the City of West Fargo, so hereby certify the foregoing to be a full, true and correct copy of the resolution adopted by the Board of City Commissioners of the City of West Fargo, at the meeting of the board held on the 3rd day of November, 2025 and that such Resolution is now part of the permanent records of the City of West Fargo, as such records are filed in the office of the City Auditor. IN WITNESS WHEREOF, I have hereunto set my hand this 3rd day of November 2025.

Dustin T. Scott
City Auditor
West Fargo, North Dakota



(Nov. 12 & 19, 2025)

November 6, 2025

██████████
██████████
WEST FARGO, ND 58078

Notice of Hearing: Next Steps for Assessed Improvements Impacting Your Property

Parcel Number: ██████████
Address: ██████████
Improvement District: 2296

Attention Property Owner,

This letter is regarding Improvement District 2296. This project involves milling and overlaying the existing roadways to improve pavement condition, enhance ride quality, and extend the pavement's service life. The district boundary for this future project includes the property you own at the address listed above. The proposed funding sources for this work include 50% of the project costs being paid via City Capital Improvements Sales Tax funds, and 50% being specially assessed to benefitting properties. An improvement district map has been included for your reference.

The current estimated total assessment for your property is \$██████████. Consistent with City policy, the proposed repayment term for this assessment is 25 years.

A "Resolution Declaring Work Necessary" for this improvement district is being published in the legal section of the 11/12/2025 and 11/19/2025 editions of the Fargo Forum as required by NDCC 40-22. This letter is additional courtesy communication from the City of West Fargo.

Property Owners may file a written protest against the creation of a special assessment district to fund this project by 12/13/2025 by 5:00 p.m. Written protests must be sent to city.auditor@westfargond.gov or to City Auditor, 2515 6th Street East, West Fargo, ND 58078.

Written protests must include the following:

1. Name(s) of all owners of the property
2. Address of the property
3. Reference to the Improvement District being protested

A public hearing has been scheduled for the December 15, 2025, City Commission Meeting beginning at 5:30p.m. During this hearing, Commissioners will review filed protests and may take further action on this project.

This is the only mailed notice that the City of West Fargo will provide for this protest opportunity. More information about the special assessments process will be mailed after construction is completed.

Thank you,
City of West Fargo Staff

2515 6th Street E
West Fargo, ND 58078
701-515-5100
engineering@westfargond.gov
westfargond.gov

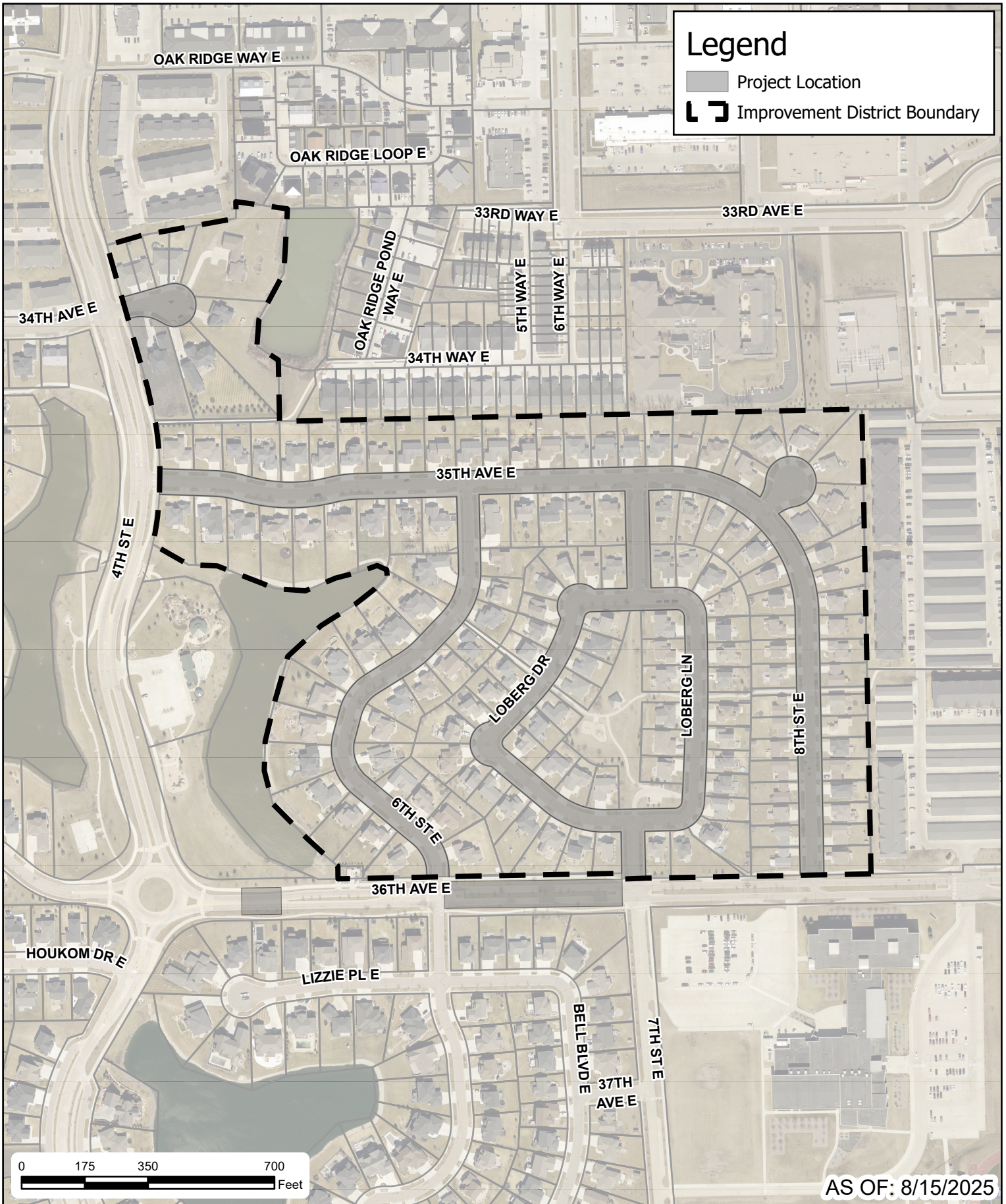

IMPROVEMENT DISTRICT MAP
IMPROVEMENT DISTRICT NO. 2296
SHADOW WOOD MILL AND OVERLAY
WEST FARGO, NORTH DAKOTA

Created By: HS/TJS Date Created: 08/07/25 Date Saved: 10/08/25 Date Exported: 10/09/25
 Plotted By: Parcel Date: 08/04/25 Aerial Image: 2023 County NAIP SIDS Elevation Data: Lidar
 Horizontal Datum: NAD 1983 StatePlane North Dakota South FIPS 3302 Feet Vertical Datum: NAVD1988
 Q:\Projects\30000\30600\30627_Dist2296ShadowWoodMillOverlay\GIS\APRX\30627_ProjectMaps.aprx

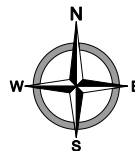

moore
 engineering, inc.

Commissioner _____ introduced the following Resolution and moved its adoption:

RESOLUTION DETERMINING THAT INSUFFICIENT PROTESTS WERE FILED ON
IMPROVEMENTS IN IMPROVEMENT DISTRICT NO. 2296 – SHADOW WOOD
NEIGHBORHOOD PAVEMENT REHABILITATION

BE IT RESOLVED by the Board of City Commissioners of the City of West Fargo, North Dakota, that said Board of City Commissioners has heretofore by Resolution determined and declared it necessary to construct an improvement in Improvement District No. 2296 – Shadow Wood Neighborhood Pavement Rehabilitation of the City of West Fargo, consisting of partial depth asphalt milling and placement of hot mix asphalt overlay necessary to improve and maintain current roadway and ride quality as well as reconstructing any pedestrian ramps withing the Improvement District that are out of ADA compliance and other appurtenances in connection with the above specified improvements and that said Resolution has been duly published as required by law, and that not less than thirty days have expired since the first publication thereof, and the opportunity having been afforded as provided by law for the property owners liable to be specially assessed for said improvement to file protests against the making thereof, and this Board having duly met to consider all protests so filed, and being fully advised in the premises, it is hereby determined that no protests were filed within the time and manner provided by law against the making of said improvement; therefore, the Board of City Commissioners and this City are authorized to proceed with the construction of the same and to pay the cost thereof by the levy of special assessments.

Dated: December 15, 2025

APPROVED:

President of Board of City

Commissioners

ATTEST:

City Auditor

The motion for the adoption of the foregoing resolution was duly seconded by **Commissioner** _____. On roll call vote, the following commissioners voted aye: _____ The following commissioners voted nay: _____ the following commissioners were absent and not voting: _____ the majority having voted aye, the motion carried and the resolution was duly adopted.



“Consent” or “Regular” Agenda
Item?
[Regular]

To: West Fargo City Commission
From: Jerry Wallace, City Engineer
Date: December 15, 2025
Subject: 2026 Sidewalk Improvements
Action: Approve Amended Engineer’s Report and Direct Engineer to prepare Plans and Specifications

Commission President

Bernie Dardis
Primary Portfolio:
 Administrative Services
Secondary Portfolio:
 Police & Fire

Commission Vice President

Brad Olson
Primary Portfolio:
 Police & Fire
Secondary Portfolio:
 Street, Water & Sewer

Commissioner

Roben Anderson
Primary Portfolio:
 Community &
 Development Services
Secondary Portfolio:
 Administrative Services

Commissioner

Rory Jorgensen
Primary Portfolio:
 Sanitation
Secondary Portfolio:
 Community &
 Development Services

Commissioner

Amy Zundel
Primary Portfolio:
 Street, Water & Sewer
Secondary Portfolio:
 Sanitation

City Administrator

Dustin T. Scott

New Information and Recommendation:

At the April 21, 2025 Commission meeting, an Engineer's Report was approved for the construction of the referenced project. A revised Engineer's Report is being brought forward as there is a legal process that is required to notify property owners to allow them to construct their sidewalks themselves within a certain timeframe. If this is not achieved, the City may install and assess those costs to the benefiting properties.

37 property owners were notified of their potential inclusion in the project in late April and given through December 1st (i.e. the 2025 construction season) to construct sidewalks themselves or initiate a Residential Building Permit. 26 property owners conformed, which leaves 11 properties to have sidewalk installed and assessed under the project.

The following documents are attached for review/consideration:

- Amended Engineer’s Report
- Amended Map of project locations throughout the city
- Associated Resolutions

Staff Recommendation: Approve Amended Engineer’s Report and Direct Engineer to prepare Plans and Specifications

Policy Analysis:

The purpose of this project is to install sidewalks throughout various residential and commercial areas throughout the City of West Fargo. The proposed project will improve the connectivity of the City's sidewalk and multi-use path system.

Within Title II (Sidewalks and Streets) of the City Ordinances, specifically Section 2-0102 (Duty of Property Owners to Construct and Maintain Sidewalks) of Chapter 2-01 (Sidewalks and Driveways), the City has the authority to install sidewalks in established areas to fill in the missing “gaps” of the system. This project periodically (historically every other year) installs necessary or required sidewalks and multi-use paths throughout the city that have not yet been installed.

By filling in the sidewalk “gaps” with this project, the City is providing pedestrian walkability through a continuous network. This work is in compliance with City Ordinance Chapter 2-01 (Sidewalks and Driveways).

Financial Analysis:

The current approved Engineer's Report showed a total cost of the project to be estimated at \$406,000.00. Property owners constructing their own

sidewalk or initiating a Residential Building Permit decreased the estimated cost of the project to \$202,000.00.

This project was listed on the adopted 2024-2028 CIP and is intended to be completed with sidewalks to be assessed at 100% of the final project costs.

Previously Presented Information and Commission Actions:

April 21, 2025 –

- **Staff Recommendation:** Create Improvement District No. 6062, Direct and Approve Engineer's Report and Authorize Notice of Order to Construct.
- **Commission Action:** Commissioner Olson moved and Commissioner Zundel seconded to approve. No opposition, motion carried.

Process for Contracts and Improvements

Improvement Process Overview

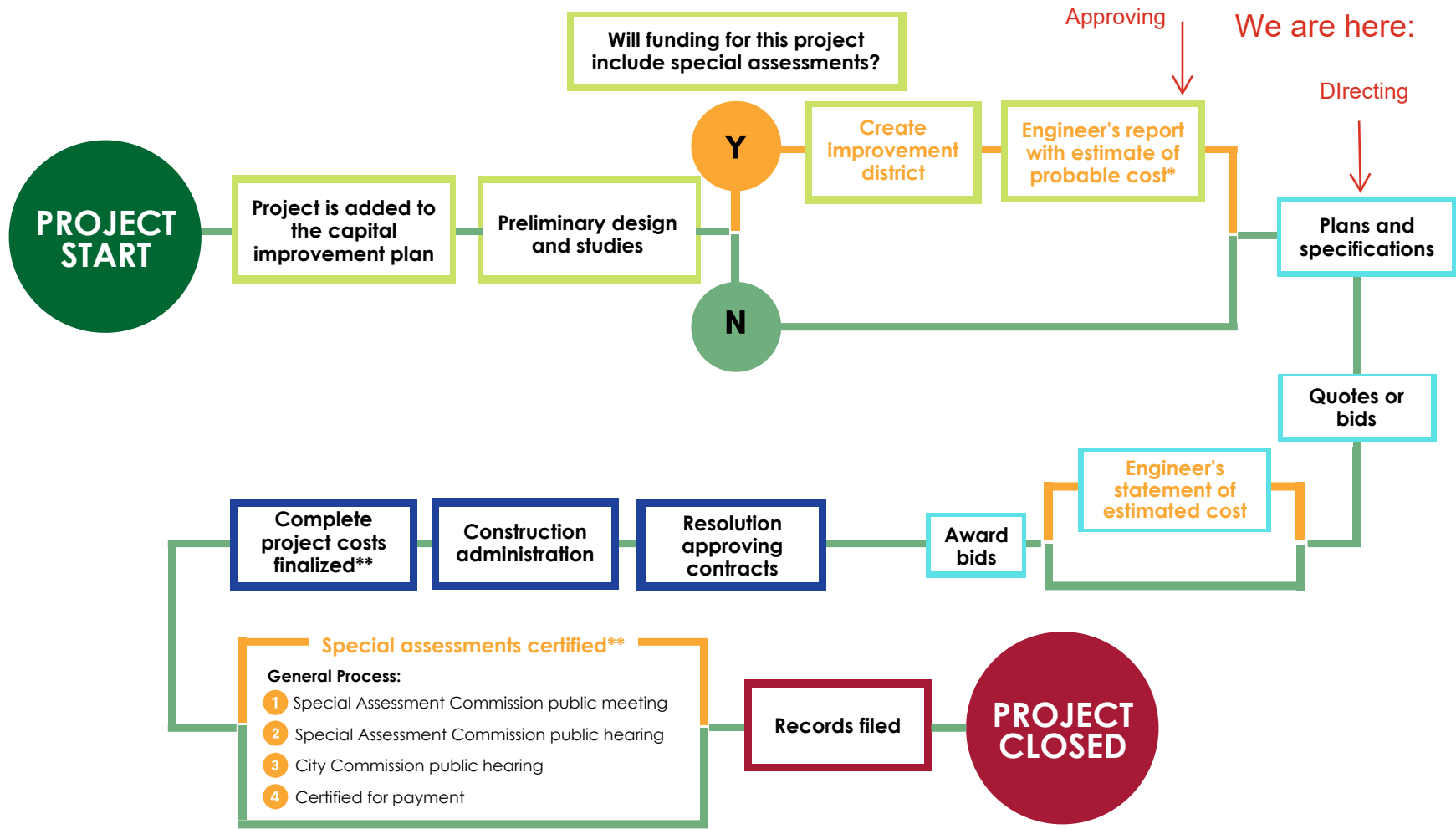

*The City of West Fargo creates an engineer's report and estimate of probable cost for most projects, but is legally required to do so for projects using special assessment funding.

**The special assessment certification process allocates the cost of the project after the complete cost of the project is final. The Special Assessment Commission does not discuss project costs.

Amended Engineer's Report

(Pursuant to N.D.C.C. 40-22-10)

Improvement District No. 6062

2026 Sidewalk Improvements

General Nature (Scope)

The purpose of this project is to install sidewalk throughout various residential and commercial areas throughout the City of West Fargo. The proposed project will improve the connectivity of the City's sidewalk and multi-use path system.

Purpose

Within Title II (Sidewalks and Streets) of the City Ordinances, specifically Section 2-0102 (Duty of Property Owners to Construct and Maintain Sidewalks) of Chapter 2-01 (Sidewalks and Driveways), the City has the authority to install sidewalks in established areas to fill in the missing "gaps" of the system. This project periodically (historically every other year) installs necessary or required sidewalks and multi-use paths throughout the city that have not yet been installed. There is a legal process that is required to notify property owners to allow them to construct their sidewalks themselves within a certain time-frame. If this is not achieved, the City may install and assess those costs to the benefiting properties.

37 property owners were notified of their potential inclusion in the project in late April and given through December 1st (i.e. the 2025 construction season) to construct sidewalks themselves or initiate a Residential Building Permit. 26 property owners conformed, which leaves 11 properties to have sidewalk installed and assessed under the project.

Feasibility

This project was listed on the adopted 2024-2028 CIP and is intended to be completed with sidewalks to be assessed at 100% of the final project costs.

District Creation Consideration (N.D.C.C 40-22-10)

Properties that will have sidewalk constructed for their property will be the only properties proposed to be assessed for this project

Estimate of Probable Cost

Construction		\$ 168,000.00
	Bid Proposal Items	\$ 152,265.50
	Contingency (~10%)	\$ 15,734.50
Engineering - Design/Construction (~11%)		\$ 19,000.00
Engineering - Materials Testing Consultant (~4%)		\$ 7,000.00
Legal & Administration (~5%)		\$ 8,000.00
<hr/>		
Total Estimated Cost		<u>\$ 202,000.00</u>

Source of Funds

Special Assessments		\$ 202,000.00
City Funds		\$0
Capital Impr. Sales Tax	\$0	
Water/Sewer Revenue	\$0	
Water/Sewer Bond	\$0	
<hr/>		
Total		<u>\$ 202,000.00</u>

Supporting Documents (available upon request)

- A. Itemized Estimate of Probable Cost
- B. Maps, Drawings, Etc.
- C. Proposed Assessments

The proposed improvements are cost effective and will adhere to city policies as well as applicable state and/or federal regulations.



Jerry Wallace, P.E.
ND Registration No. 27431

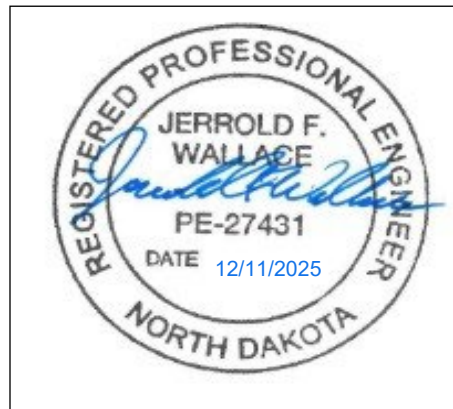

Improvement District No. 6062
2026 Sidewalk Improvements
Prairie Parkway Area
December 15, 2025

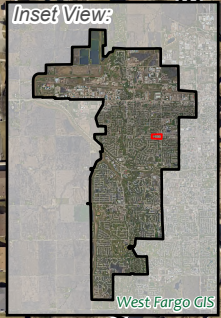

Improvement District No. 6062
2026 Sidewalk Improvements
The Preserve Area
December 15, 2025

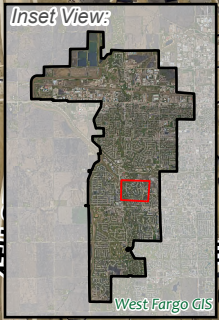
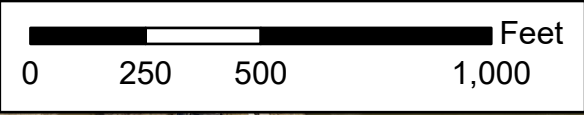
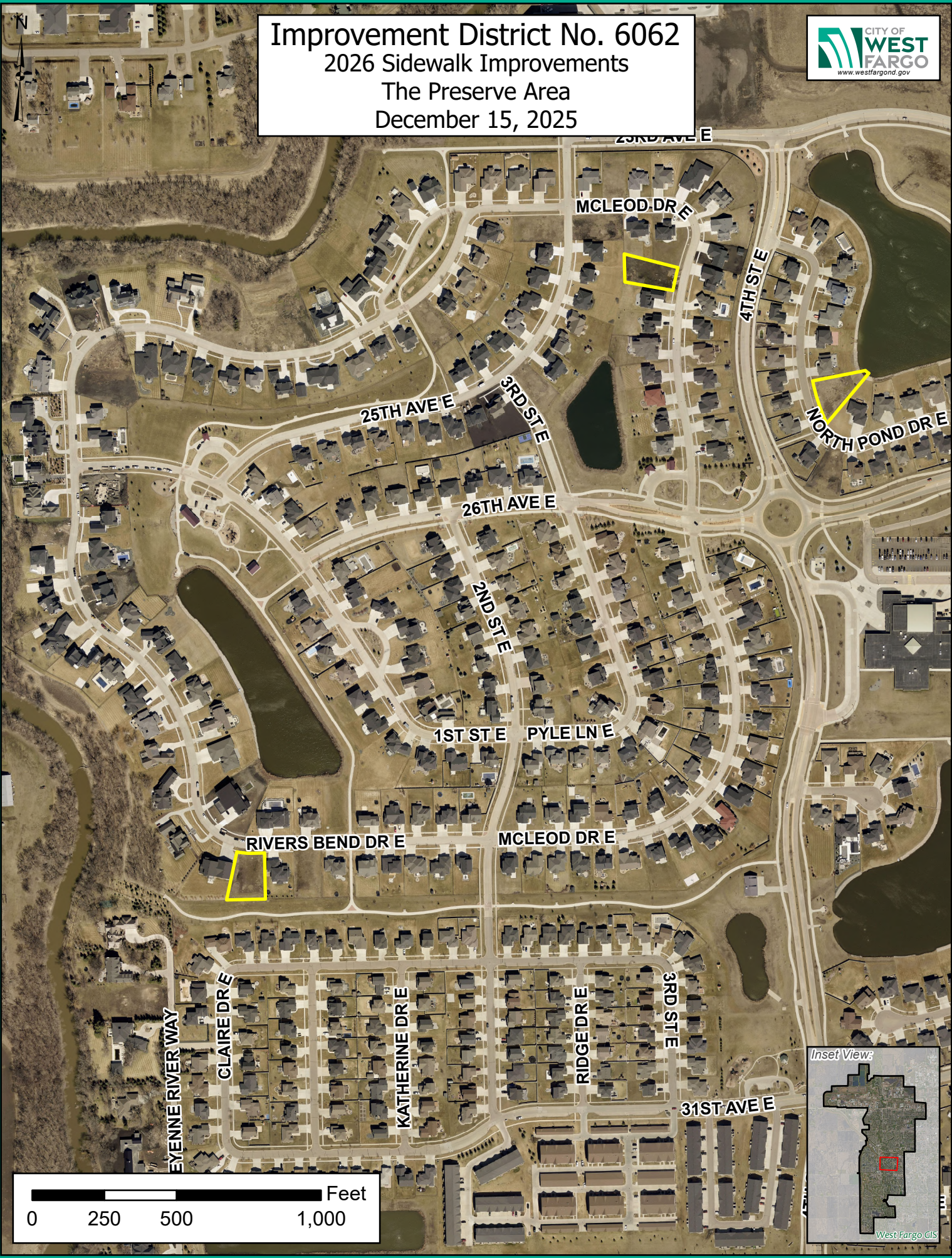

Improvement District No. 6062
2026 Sidewalk Improvements
Westview Area
December 15, 2025

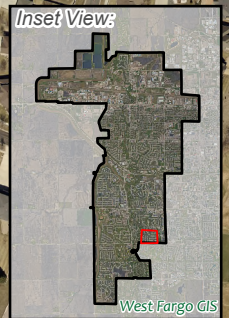
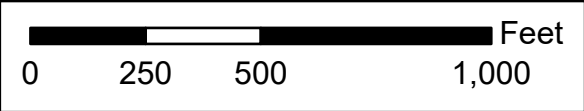
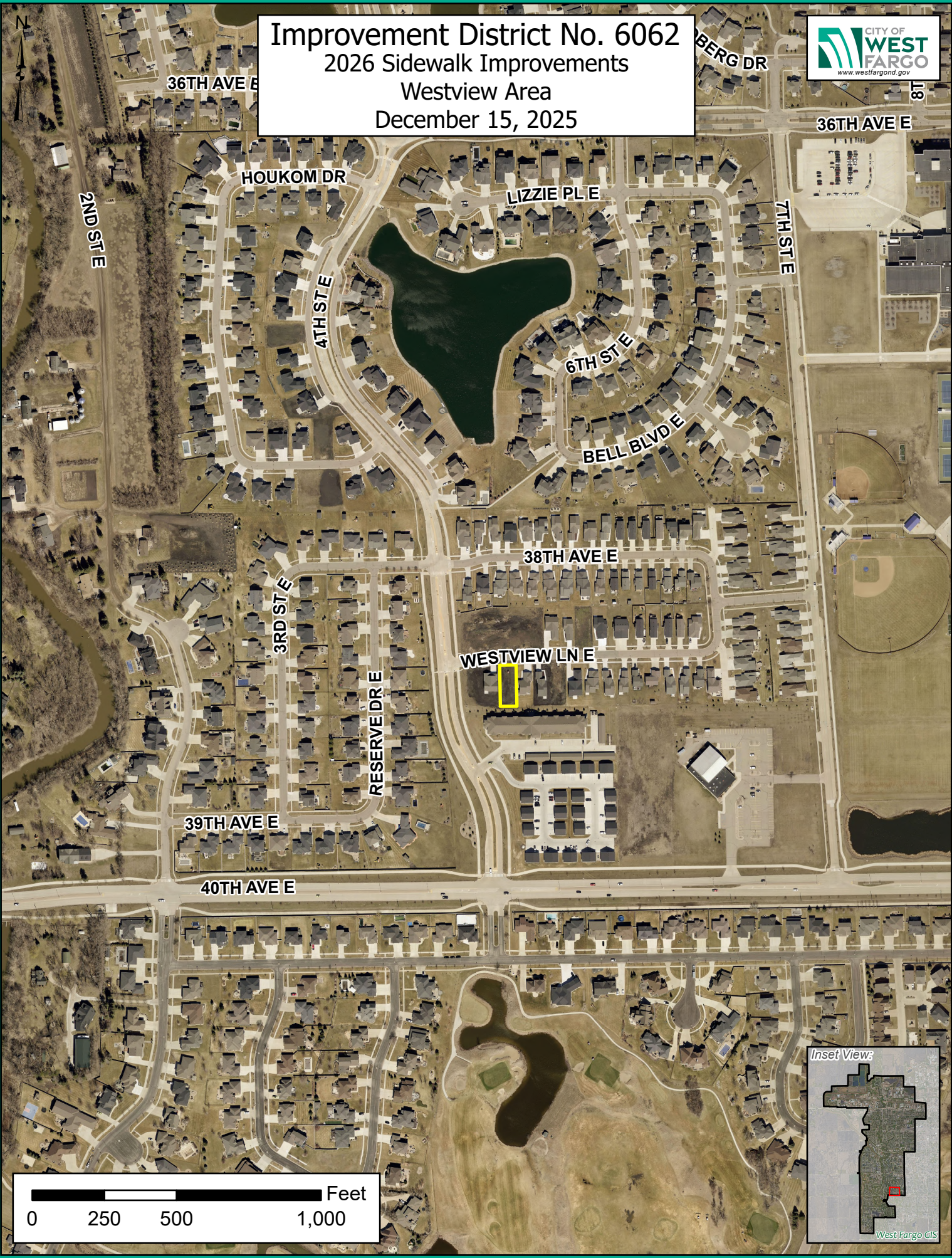

Improvement District No. 6062
2026 Sidewalk Improvements
Wilds North Area
December 15, 2025

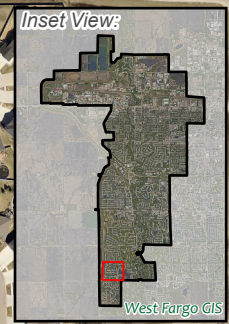
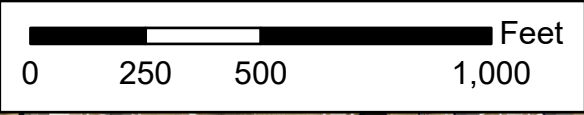

Improvement District No. 6062
2026 Sidewalk Improvements
Wilds South Area
December 15, 2025

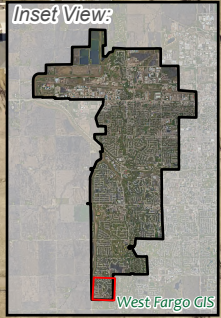
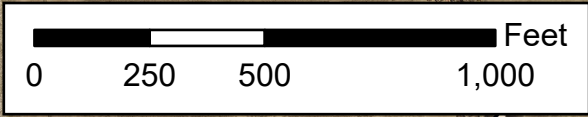

Commissioner _____ introduced the following resolution and moved its adoption:

RESOLUTION APPROVING AMENDED ENGINEER'S REPORT

BE IT RESOLVED by the Board of City Commissioners of the City of West Fargo, North Dakota, that the amended report of the Engineer for the City of West Fargo as to the general nature, purpose and feasibility along with an estimate of the probable cost of the work has been filed with this Board and that the same is hereby approved for Sidewalk District No. 6062.

Dated: December 15, 2025

APPROVED:

President of Board of City Commissioners

ATTEST:

City Auditor

The motion for the adoption of the foregoing resolution was duly seconded by Commissioner _____. Upon roll call vote being taken thereon, the following commissioners voted in favor thereof: _____. The following commissioners were absent and not voting: _____. The following commissioners voted nay: _____. The majority having voted aye, the motion was carried and the resolution was duly adopted.

Commissioner _____ introduced the following resolution and moved its adoption:

RESOLUTION DIRECTING ENGINEER
TO PREPARE PLANS AND SPECIFICATIONS

BE IT RESOLVED by the Board of City Commissioners of the City of West Fargo, deeming it necessary to make certain improvements consisting of installing sidewalks in established areas to fill in the missing gaps of the system in connection with the above specified improvements, be constructed and made in Sidewalk District No. 6062 of the City of West Fargo, the City hereby directs Jerry Wallace, the Engineer for the City of West Fargo and being a competent engineer, to prepare plans and specifications for such work.

Dated: December 15, 2025

APPROVED:

President of Board of City Commissioners

ATTEST:

City Auditor

The motion for the adoption of the foregoing resolution was duly seconded by Commissioner _____. Upon roll call vote being taken thereon, the following commissioners voted in favor thereof: _____.

The following commissioners were absent and not voting: _____. The following commissioners voted nay: _____. The majority having voted aye, the motion was carried and the resolution was duly adopted.



“Consent” or “Regular” Agenda Item?
[Regular]

To: West Fargo City Commission
From: Jerry Wallace, City Engineer
Date: December 15, 2025
Subject: Project No. 2284 - 2026 HSIP Intersections – Turn Lane Realignment 9th St. E./19th Ave. E., 32nd Ave. E./4th St. E., & Sheyenne St./38th Ave. W.
Action: Review bid and concur with NDDOT’s recommendation

Commission President

Bernie Dardis
Primary Portfolio:
 Administrative Services
Secondary Portfolio:
 Police & Fire

Commission Vice President

Brad Olson
Primary Portfolio:
 Police & Fire
Secondary Portfolio:
 Street, Water & Sewer

Commissioner

Roben Anderson
Primary Portfolio:
 Community & Development Services
Secondary Portfolio:
 Administrative Services

Commissioner

Rory Jorgensen
Primary Portfolio:
 Sanitation
Secondary Portfolio:
 Community & Development Services

Commissioner

Amy Zundel
Primary Portfolio:
 Street, Water & Sewer
Secondary Portfolio:
 Sanitation

City Administrator

Dustin T. Scott

New Information and Recommendation:

The NDDOT conducted a virtual bid opening on November 14, 2025. There was a total of six (6) bidders, with Northern Improvement Company as the low bidder. The low bid was \$656,717.20, which was \$180,447.10 (37.9%) above the Engineer’s design estimate. Staff recommends awarding the contract to Northern Improvement Company.

The following documents are attached for review/consideration:

- NDDOT Notice of Bids
- Resolution Accepting Bid

Staff Recommendation: Concur with NDDOT and award the contract to Northern Improvement Company.

Background and Project Summary:

The city in 2021 applied for and was awarded a Highway Safety Improvement Program (HSIP) grant. The grant covers a portion of the construction costs and the project is expected to be constructed in the summer of 2026.

Policy Analysis:

This project will align the turning lanes to significantly improve intersection safety by allowing drivers to see oncoming traffic more clearly.

Financial Analysis:

This project is included in the 2024 CIP and has been awarded a federal HSIP grant of \$471,507.40 toward construction costs. Remaining construction and soft costs are proposed to come from the Capital Improvement Sales Tax fund.

A bid analysis for the project shows that all six bids were significantly higher than the Engineer’s Estimate (EE) of \$476,270.10, ranging from \$656,717.20 (138% of the EE) to \$855,717.50 (180% of the EE). The primary cost increases were concentrated in lighting and traffic signal system items, which all bidders priced well above the estimate. When excluding two clear outliers, the four lowest bidders were only 4–8% above the EE for all other items, suggesting those portions of the work were reasonably priced. The elevated electrical costs appear to be driven by market conditions, including rising material and electronics prices, Build America Buy America (BABA)- related supply risks, shortened quote validity, scheduling uncertainties, higher risk premiums due to liquidated damages, and limited subcontractor participation. With only one subcontractor providing pricing and others

either declining to bid or bidding high due to workload constraints, competition was limited, further inflating costs.

Given the specialized nature of signal and lighting work on transportation projects, these market and competitive trends are likely to continue to influence future estimates and bids. Because only a limited number of contractors perform this type of work, the subcontractor pool is much smaller than for more common civil items like earthwork or paving. As a result, pricing is more sensitive to market conditions, workload, and subcontractor availability, resulting in greater bid variability than for typical roadway items.

Previously Presented Information and Commission Actions:

September 8, 2025 –

- **Staff Recommendation:** Direct and Approve Engineer's Report, Direct and Approve Plans and Specifications; and Direct Advertisement for Bids by NDDOT
- **Commission Action:** Commissioner Olson moved and Commissioner Anderson seconded to approve. No opposition, motion carried.

November 18, 2024 -

- **Staff Recommendation:** Create Project No. 2284 and approve Task Order No. 6 with Bolton & Menk in the amount of \$63,360.
- **Commission Action:** Commissioner Olson moved, and Commissioner Anderson seconded to approve. No opposition, motion carried.

December 6, 2021 -

- **Staff Recommendation:** Approve grant applications and Authorize Mayor to sign letters of support.
- **Commission Action:** Commissioner Olson moved, and Commissioner George seconded to approve. No opposition, motion carried.

CITY PROJECT PROCESS FLOW CHART

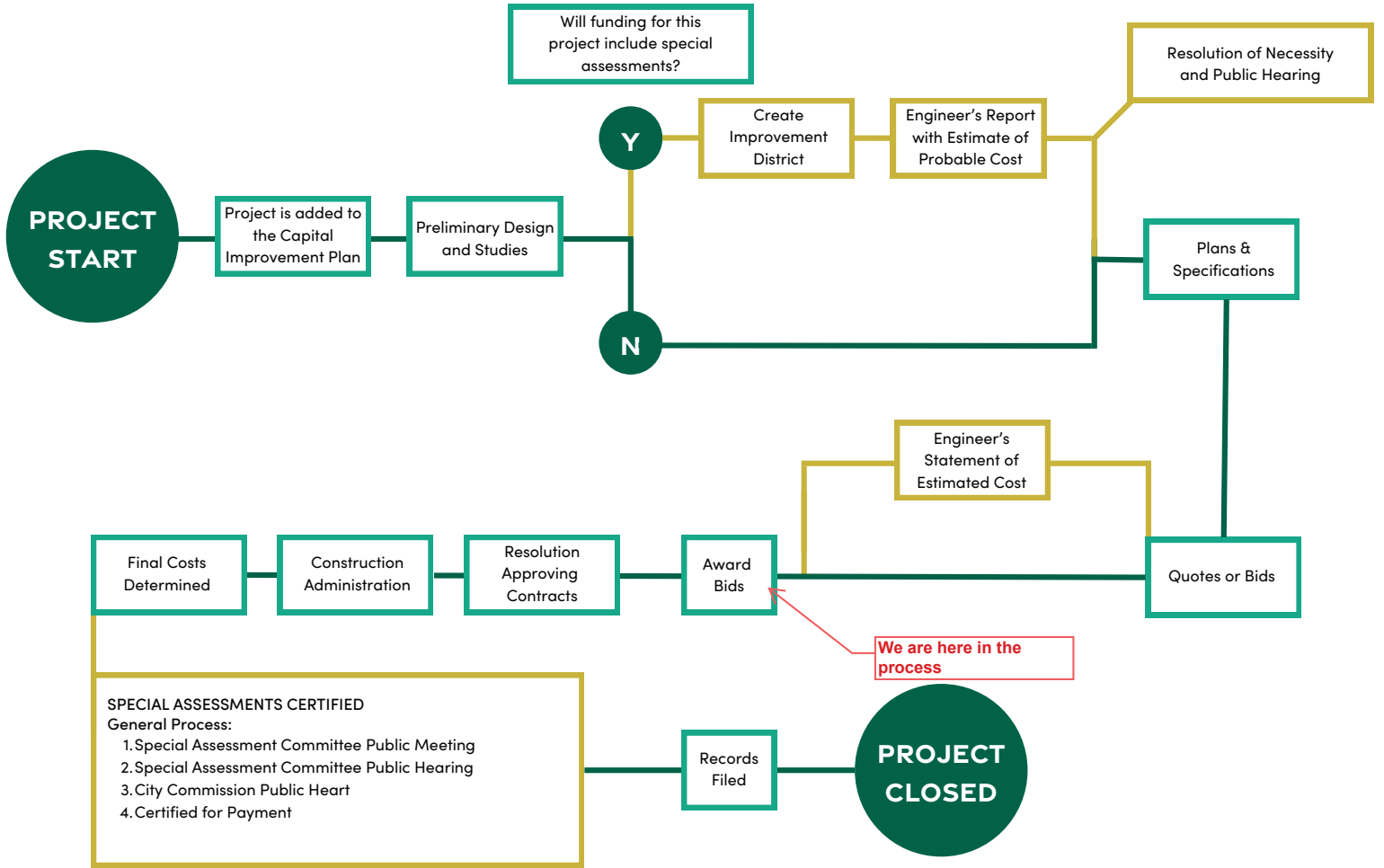

*The City of West Fargo creates an Engineer's Report and Estimate of Probably Cost for most projects, but is legally required to do so for projects using special assessment funding.

*Project Steps in YELLOW boxes are only necessary when a project is funding through the use of special assessments.

November 14, 2025

Jerry Wallace
City Engineer
800 4th Ave East, Suite #1
West Fargo, ND 58078

PROJECT: HEU-8-992(049), PCN 24052 – INTERSECTIONS OF 9TH ST E & 19TH AVE E, 32ND AVE E & 4TH ST E AND SHEYENNE ST & 38TH AVE W - WEST FARGO

Dear Mr. Wallace:

Bids for the construction on the above noted project were taken at our bid opening of November 14, 2025. A copy of the Contract Detail Estimate and Abstract of Bids are enclosed.

The low bid for Signal, Turn Lane, Lighting, and Pavement Marking Modifications was submitted by Northern Improvement Company of Fargo, ND in the amount of \$656,717.20. According to the agreement with the City of West Fargo, the City's share for **HEU-8-992(049)** is estimated to be \$250,881.52. HEU Federal Funds is Limited to \$471,507.40. The balance of the project cost is the obligation of the City.

The Department will review the low bidder's proposal to assure that the Disadvantaged Business Enterprise Program requirements have been met. Upon review of the contractor's Disadvantaged Business Enterprise Program, the Department will advise you via email whether this project may be awarded. The City must award the contract before the Department will concur in the award; therefore, the City must notify the Department in writing as soon as possible after the award is made. Contracts cannot be executed prior to the date of the Department's concurrence.

Questions should be addressed to the Construction Services Division at 701-328-2566.

Sincerely,



Phillip Murdoff, PE
Construction Services Engineer

80/pm/jmm
Enclosure

North Dakota **FEDERAL AID**

Bid Opening Date: **11/14/2025**

Project Number: **HEU-8-992(049)**

PCN: **24052**

Job Number: **24052**

English/Metric: **ENGLISH**

Contract with **NORTHERN IMPROVEMENT COMPANY FARGO, ND**

Signed Date:

County(s): **CASS**

Location: **INTERSECTIONS OF 9TH ST E & 19TH AVE E, 32ND AVE E & 4TH ST E AND SHEYENNE ST & 38TH AVE W - WEST
FARGO**

North Dakota **FEDERAL AID**

Bid Opening Date: **11/14/2025**

Project Number: **HEU-8-992(049)**

PCN: **24052**

Job Number: **24052**

English/Metric: **ENGLISH**

Roadway: **URBAN**

9TH, L1974_017M MEASURE 0.2517
32ND, L1976_017M MEASURE 0.5605
SHEYENNE, L1966_017M MEASURE 2.3160

Type: **SIGNAL, TURN LANE, LIGHTING, PAVEMENT MARKING MODIFICATIONS**

Participating: **Y**

Spec	Code	Item Description	Quantity	Unit	Unit Price	Amount
103	0100	CONTRACT BOND	1.000	L SUM	\$1,805.00	\$1,805.00
202	0114	REMOVAL OF CONCRETE PAVEMENT	587.000	SY	\$27.00	\$15,849.00
202	0130	REMOVAL OF CURB & GUTTER	1,558.000	LF	\$15.00	\$23,370.00
203	0113	COMMON EXCAVATION-WASTE	432.000	CY	\$36.00	\$15,552.00
302	0121	AGGREGATE BASE COURSE CL 5	262.000	CY	\$115.00	\$30,130.00
430	0500	COMMERCIAL GRADE HOT MIX ASPHALT	84.000	TON	\$262.00	\$22,008.00
550	0300	8IN NON-REINF CONCRETE PVMT CL AE-DOWELED	172.000	SY	\$150.00	\$25,800.00
550	0310	10IN NON REINF CONCRETE PVMT CL AE-DOWELED	644.000	SY	\$160.00	\$103,040.00
702	0100	MOBILIZATION	1.000	L SUM	\$44,400.00	\$44,400.00
704	1000	TRAFFIC CONTROL SIGNS	934.000	UNIT	\$2.10	\$1,961.40
704	1052	TYPE III BARRICADE	12.000	EA	\$105.00	\$1,260.00
704	1054	SIDEWALK BARRICADE	4.000	EA	\$63.00	\$252.00
704	1060	DELINEATOR DRUMS	145.000	EA	\$21.00	\$3,045.00
704	1500	OBLITERATION OF PAVEMENT MARKING	333.000	SF	\$8.40	\$2,797.20
708	1540	INLET PROTECTION-SPECIAL	10.000	EA	\$250.00	\$2,500.00
709	0151	GEOSYNTHETIC MATERIAL TYPE R1	1,000.000	SY	\$5.25	\$5,250.00
750	0210	CONCRETE MEDIAN NOSE PAVING	42.000	SY	\$188.00	\$7,896.00
754	0110	FLAT SHEET FOR SIGNS-TYPE XI REFL SHEETING	75.000	SF	\$93.00	\$6,975.00
754	0149	RESET DELINEATOR	4.000	EA	\$52.50	\$210.00
754	0592	RESET SIGN PANEL	3.000	EA	\$63.00	\$189.00
754	0593	RESET SIGN SUPPORT	2.000	EA	\$210.00	\$420.00
762	0110	EPOXY PVMT MK 4IN LINE-GROOVED	2,044.000	LF	\$6.60	\$13,490.40
762	0132	EPOXY PVMT MK 8IN LINE-GROOVED	1,816.000	LF	\$13.20	\$23,971.20
762	0135	EPOXY PVMT MK 24IN LINE-GROOVED	132.000	LF	\$38.50	\$5,082.00
762	0136	EPOXY PVMT MK MESSAGE-GROOVED	112.000	SF	\$22.00	\$2,464.00
770	9400	LIGHTING SYSTEM (ROADWAY)	1.000	L SUM	\$110,000.00	\$110,000.00
772	9811	TRAFFIC SIGNAL SYSTEM - SITE 1	1.000	EA	\$71,500.00	\$71,500.00
772	9812	TRAFFIC SIGNAL SYSTEM - SITE 2	1.000	EA	\$82,500.00	\$82,500.00
772	9813	TRAFFIC SIGNAL SYSTEM - SITE 3	1.000	EA	\$33,000.00	\$33,000.00
Subtotal						\$656,717.20

North Dakota **FEDERAL AID**

Bid Opening Date: **11/14/2025**

Project Number: **HEU-8-992(049)**

PCN: **24052**

Job Number: **24052**

English/Metric: **ENGLISH**

Eng and Contg **\$65,671.72**

Total **\$722,388.92**

Length **0.0000 Miles**

		<u>Construction</u>
Estimated Cost		\$722,388.92
HEU FEDERAL FUNDS	LIMITED	\$471,507.40
HEU WEST FARGO FUNDS	10.00%	\$250,881.52

Summary for Project

Length **0.0000 Miles**

Estimated Total Construction Cost:	\$656,717.20
Estimated Total Eng and Contg:	\$65,671.72

	<u>Construction</u>	<u>Total</u>
Estimated Cost	\$722,388.92	\$722,388.92
HEU FEDERAL FUNDS	\$471,507.40	\$471,507.40
HEU WEST FARGO FUNDS	\$250,881.52	\$250,881.52

NDDOT TO MAKE CONTRACTOR PAYMENTS. HEU FEDERAL FUNDS FOR THIS PROJECT IS LIMITED TO \$ 471,507.40. ANY COSTS OVER THIS LIMITED AMOUNT WILL BE CITY RESPONSIBILITY.

ND DEPARTMENT OF TRANSPORTATION

SHEET NO 1 OF 3

ABSTRACT OF BIDS RECEIVED

PROJECT NO. HEU-8-992(049)		NO. 24052		BIDDER ENGINEERS ESTIMATE		BIDDER NORTHERN IMPROVEMENT COMPANY		BIDDER BORDER STATES PAVING INC	
COUNTY & DATE CASS (017) NOV 14, 2025 09:30AM						FARGO, ND		FARGO, ND	
LENGTH & TYPE 0.000						FARGO, ND		FARGO, ND	
COMPLETION TIME 09/11/26 SIGNAL, TURN LANE, LIGHTING, PAVEMENT				c.c. CHECK RANK 00		c.c. BOND RANK 01		c.c. BOND RANK 02	
SPEC. NO.	ITEM DESCRIPTION	UNIT	QUANTITY	BID PRICE	AMOUNT	BID PRICE	AMOUNT	BID PRICE	AMOUNT
103	CONTRACT BOND	L SUM	1000	6400000	6400000	1805000	1805000	2440000	2440000
202	REMOVAL OF CONCRETE PAVEMENT	SY	587000	21000	1232700	27000	1584900	22400	1314880
202	REMOVAL OF CURB & GUTTER	LF	1558000	22000	3427600	15000	2337000	16800	2617440
203	COMMON EXCAVATION-WASTE	CY	432000	20000	864000	36000	1555200	35000	1512000
302	AGGREGATE BASE COURSE CL 5	CY	262000	120000	3144000	115000	3013000	103000	2698600
430	COMMERCIAL GRADE HOT MIX ASPHALT	TON	84000	350000	2940000	262000	2200800	275000	2310000
550	8IN NON-REINF CONCRETE PVMT CL AE-DOWELED	SY	172000	150000	2580000	150000	2580000	163000	2803600
550	10IN NON REINF CONCRETE PVMT CL AE-DOWELED	SY	644000	160000	10304000	160000	10304000	173000	11141200
702	MOBILIZATION	L SUM	1000	5000000	5000000	4440000	4440000	5210000	5210000
704	TRAFFIC CONTROL SIGNS	UNIT	934000	2400	224160	2100	196140	2100	196140
704	TYPE III BARRICADE	EA	12000	120000	144000	105000	126000	105000	126000
704	SIDEWALK BARRICADE	EA	4000	75000	30000	63000	25200	63100	25240
704	DELINEATOR DRUMS	EA	145000	22000	319000	21000	304500	21000	304500
704	OBLITERATION OF PAVEMENT MARKING	SF	333000	2500	83250	8400	279720	8400	279720
708	INLET PROTECTION-SPECIAL	EA	10000	250000	250000	250000	250000	247000	247000
709	GEOSYNTHETIC MATERIAL TYPE R1	SY	1000000	4300	430000	5250	525000	5350	535000
750	CONCRETE MEDIAN NOSE PAVING	SY	42000	175000	735000	188000	789600	258000	1083600
754	FLAT SHEET FOR SIGNS-TYPE XI REFL SHEETING	SF	75000	50000	375000	93000	697500	93000	697500
754	RESET DELINEATOR	EA	4000	65000	26000	52500	21000	52600	21040
754	RESET SIGN PANEL	EA	3000	110000	33000	63000	18900	63100	18930
754	RESET SIGN SUPPORT	EA	2000	320000	64000	210000	42000	21000	42000
762	EPOXY PVMT MK 4IN LINE-GROOVED	LF	2044000	3750	766500	6600	1349040	6300	1287720
762	EPOXY PVMT MK 8IN LINE-GROOVED	LF	1816000	7500	1362000	13200	2397120	12600	2288160
762	EPOXY PVMT MK 24IN LINE-GROOVED	LF	132000	32500	429000	38500	508200	36800	485760
762	EPOXY PVMT MK MESSAGE-GROOVED	SF	112000	24000	268800	22000	246400	21000	235200
770	LIGHTING SYSTEM (ROADWAY)	L SUM	1000	6400000	6400000	11000000	11000000	105124610	105124610
772	TRAFFIC SIGNAL SYSTEM - SITE 1	EA	1000	1605000	1605000	7150000	7150000	6830000	6830000
772	TRAFFIC SIGNAL SYSTEM - SITE 2	EA	1000	2500000	2500000	8250000	8250000	7880000	7880000
772	TRAFFIC SIGNAL SYSTEM - SITE 3	EA	1000	1450000	1450000	3300000	3300000	3150000	3150000
TOTAL					47627010		65671720		66097691
						NO LIMIT		NO LIMIT	

ACTION TAKEN BY DEPARTMENT OF TRANSPORTATION
Deputy Director For Engineering:

AWARD TO: NORTHERN IMPROVEMENT COMPANY

WHEN PRELIMINARY ARRANGEMENTS ARE COMPLETED.

62

DATE OF AWARD

DEPARTMENT OF TRANSPORTATION Deputy Director For Engineering

ND DEPARTMENT OF TRANSPORTATION

SHEET NO 2 OF 3

ABSTRACT OF BIDS RECEIVED

PROJECT NO. HEU-8-992(049)		NO. 24052		BIDDER OPP CONSTRUCTION LLC		BIDDER STRATA CORPORATION		BIDDER TI-ZACK CONCRETE LLC			
COUNTY & DATE CASS (017) NOV 14, 2025 09:30AM		LENGTH & TYPE 0.000		COMPLETION TIME 09/11/26 SIGNAL, TURN LANE, LIGHTING, PAVEMENT		GRAND FORKS, ND		GRAND FORKS, ND		LE CENTER, MN	
SPEC. NO.		ITEM DESCRIPTION		QUANTITY	BID PRICE	AMOUNT	BID PRICE	AMOUNT	BID PRICE	AMOUNT	
103	CONTRACT BOND	L SUM	1000	5900000	5900000	2430660	2430660	1100000	1100000	1100000	
202	REMOVAL OF CONCRETE PAVEMENT	SY	587000	38000	2230600	27000	1584900	27190	1596053	1596053	
202	REMOVAL OF CURB & GUTTER	LF	1558000	14500	2259100	15000	2337000	10240	1595392	1595392	
203	COMMON EXCAVATION-WASTE	CY	432000	52000	2246400	36000	1555200	55420	2394144	2394144	
302	AGGREGATE BASE COURSE CL 5	CY	262000	82000	2148400	115000	3013000	116920	3063304	3063304	
430	COMMERCIAL GRADE HOT MIX ASPHALT	TON	84000	500000	4200000	262000	2200800	330000	2772000	2772000	
550	8IN NON-REINF CONCRETE PVMT CL AE-DOWELED	SY	172000	155000	2666000	150000	2580000	242410	4169452	4169452	
550	10IN NON REINF CONCRETE PVMT CL AE-DOWELED	SY	644000	165000	10626000	160000	10304000	296510	19095244	19095244	
702	MOBILIZATION	L SUM	1000	85000000	85000000	103147620	103147620	56276080	56276080	56276080	
704	TRAFFIC CONTROL SIGNS	UNIT	934000	4350	406290	4000	373600	2200	205480	205480	
704	TYPE III BARRICADE	EA	12000	86500	1038000	80000	960000	1100000	1320000	1320000	
704	SIDEWALK BARRICADE	EA	4000	53000	212000	49000	196000	660000	264000	264000	
704	DELINEATOR DRUMS	EA	145000	20500	2972500	19000	2755000	22000	3190000	3190000	
704	OBLITERATION OF PAVEMENT MARKING	SF	333000	3000	999000	8000	2664000	8800	2930400	2930400	
708	INLET PROTECTION-SPECIAL	EA	10000	200000	2000000	235000	2350000	1925000	1925000	1925000	
709	GEOSYNTHETIC MATERIAL TYPE R1	SY	1000000	4600	4600000	5250	5250000	8560	8560000	8560000	
750	CONCRETE MEDIAN NOSE PAVING	SY	42000	400000	16800000	188000	7896000	242410	10181220	10181220	
754	FLAT SHEET FOR SIGNS-TYPE XI REFL SHEETING	SF	75000	85350	6401250	79000	5925000	97350	7301250	7301250	
754	RESET DELINEATOR	EA	4000	52000	208000	48000	192000	55000	220000	220000	
754	RESET SIGN PANEL	EA	3000	91000	273000	84000	252000	66000	198000	198000	
754	RESET SIGN SUPPORT	EA	2000	200000	400000	185000	370000	220000	440000	440000	
762	EPOXY PVMT MK 4IN LINE-GROOVED	LF	2044000	7000	14308000	6000	12264000	6600	13490400	13490400	
762	EPOXY PVMT MK 8IN LINE-GROOVED	LF	1816000	13000	23608000	12000	21792000	13200	23971200	23971200	
762	EPOXY PVMT MK 24IN LINE-GROOVED	LF	132000	38000	5016000	35000	4620000	38500	5082000	5082000	
762	EPOXY PVMT MK MESSAGE-GROOVED	SF	112000	22000	2464000	20000	2240000	22000	2464000	2464000	
770	LIGHTING SYSTEM (ROADWAY)	L SUM	1000	108000000	108000000	191926070	191926070	121000000	121000000	121000000	
772	TRAFFIC SIGNAL SYSTEM - SITE 1	EA	1000	71000000	71000000	32099360	32099360	71500000	71500000	71500000	
772	TRAFFIC SIGNAL SYSTEM - SITE 2	EA	1000	81000000	81000000	56980990	56980990	82500000	82500000	82500000	
772	TRAFFIC SIGNAL SYSTEM - SITE 3	EA	1000	32400000	32400000	40769490	40769490	33000000	33000000	33000000	
TOTAL						73242765		73656519		79582424	
					NO LIMIT		NO LIMIT		NO LIMIT		
ACTION TAKEN BY DEPARTMENT OF TRANSPORTATION Deputy Director For Engineering:		AWARD TO: NORTHERN IMPROVEMENT COMPANY		WHEN PRELIMINARY ARRANGEMENTS ARE COMPLETED.							
63		DATE OF AWARD						DEPARTMENT OF TRANSPORTATION Deputy Director For Engineering			

ND DEPARTMENT OF TRANSPORTATION

SHEET NO 3 OF 3

ABSTRACT OF BIDS RECEIVED

PROJECT NO. HEU-8-992(049)		NO. 24052		BIDDER SELLIN BROTHERS INC		BIDDER		BIDDER	
COUNTY & DATE CASS (017) NOV 14, 2025 09:30AM				HAWLEY, MN					
LENGTH & TYPE 0.000									
COMPLETION TIME 09/11/26 SIGNAL, TURN LANE, LIGHTING, PAVEMENT				C.C. BOND RANK 06		C.C.		C.C.	
SPEC. NO.	ITEM DESCRIPTION	UNIT	QUANTITY	BID PRICE	AMOUNT	BID PRICE	AMOUNT	BID PRICE	AMOUNT
103	CONTRACT BOND	L SUM	1000	4500000	4500000				
202	REMOVAL OF CONCRETE PAVEMENT	SY	587000	100000	5870000				
202	REMOVAL OF CURB & GUTTER	LF	1558000	43000	6699400				
203	COMMON EXCAVATION-WASTE	CY	432000	30000	1296000				
302	AGGREGATE BASE COURSE CL 5	CY	262000	100000	2620000				
430	COMMERCIAL GRADE HOT MIX ASPHALT	TON	84000	500000	4200000				
550	8IN NON-REINF CONCRETE PVMT CL AE-DOWELED	SY	172000	185000	3182000				
550	10IN NON REINF CONCRETE PVMT CL AE-DOWELED	SY	644000	200000	12880000				
702	MOBILIZATION	L SUM	1000	8500000	8500000				
704	TRAFFIC CONTROL SIGNS	UNIT	934000	2250	2101500				
704	TYPE III BARRICADE	EA	12000	120000	1440000				
704	SIDEWALK BARRICADE	EA	4000	70000	280000				
704	DELINEATOR DRUMS	EA	145000	23000	3335000				
704	OBLITERATION OF PAVEMENT MARKING	SF	333000	10000	3330000				
708	INLET PROTECTION-SPECIAL	EA	10000	300000	3000000				
709	GEOSYNTHETIC MATERIAL TYPE R1	SY	1000000	6000	6000000				
750	CONCRETE MEDIAN NOSE PAVING	SY	42000	300000	12600000				
754	FLAT SHEET FOR SIGNS-TYPE XI REFL SHEETING	SF	75000	105000	7875000				
754	RESET DELINEATOR	EA	4000	60000	240000				
754	RESET SIGN PANEL	EA	3000	70000	210000				
754	RESET SIGN SUPPORT	EA	2000	240000	480000				
762	EPOXY PVMT MK 4IN LINE-GROOVED	LF	2044000	7000	14308000				
762	EPOXY PVMT MK 8IN LINE-GROOVED	LF	1816000	14000	25424000				
762	EPOXY PVMT MK 24IN LINE-GROOVED	LF	132000	42000	5544000				
762	EPOXY PVMT MK MESSAGE-GROOVED	SF	112000	23000	2576000				
770	LIGHTING SYSTEM (ROADWAY)	L SUM	1000	115000000	115000000				
772	TRAFFIC SIGNAL SYSTEM - SITE 1	EA	1000	75000000	75000000				
772	TRAFFIC SIGNAL SYSTEM - SITE 2	EA	1000	85000000	85000000				
772	TRAFFIC SIGNAL SYSTEM - SITE 3	EA	1000	35000000	35000000				
TOTAL						85571750			
					NO LIMIT				
ACTION TAKEN BY DEPARTMENT OF TRANSPORTATION Deputy Director For Engineering:		AWARD TO: NORTHERN IMPROVEMENT COMPANY			WHEN PRELIMINARY ARRANGEMENTS ARE COMPLETED.				
64		DATE OF AWARD			DEPARTMENT OF TRANSPORTATION Deputy Director For Engineering				

Commissioner _____ introduced the following resolution and moved its adoption:

RESOLUTION ACCEPTING BID, SHOWING
RECEIPT OF ENGINEER'S STATEMENT OF ESTIMATED COST
AND DIRECTING EXECUTION OF CONTRACT

WHEREAS, bids have heretofore been received for the making of certain improvements in Project No. 2284 – 2026 HSIP Intersections – Turn Lane Realignments of the City of West Fargo, North Dakota; and

WHEREAS, said bids were opened and made public and are on file in the office of the City Auditor of the City of West Fargo; and

WHEREAS, the Engineer for the City of West Fargo has made and filed a careful and detailed statement of the estimated cost of said work; and

WHEREAS, it is necessary to accept the bid for the work to be completed;

NOW THEREFORE, BE IT RESOLVED AS FOLLOWS:

That the fact is and that the minutes show that the bid of Northern Improvement Company, in the amount of \$656,717.20 is the lowest bid received and that said company is the lowest responsible bidder; that said bid was accompanied by a bidder's bond in the amount of 5% of the bid price and copy of the contractor's license or certificate of renewal thereof and in conformity with the provisions of Chapter 40-29 of the North Dakota Century Code

That the Engineer for the City of West Fargo, has made and filed with the Board of City Commissioners of the City of West Fargo a careful and detailed statement of the estimated cost of said work in said Project No. 2284;

That the contract for the construction of said improvement for which advertisement for bids is made, be and the same is hereby awarded to the said Northern Improvement Company, in the amount of \$656,717.20 and that the President of the Board of City Commissioners and the City Auditor are hereby authorized and directed to enter into a contract with the said contractor for the making of the improvements for which advertisement for bids was heretofore made and for which they were the low bidder.

Dated: December 15, 2025

APPROVED:

President of Board of City Commissioners

ATTEST:

City Auditor

The motion for the adoption of the foregoing resolution was duly seconded by Commissioner _____. Upon roll call vote being taken thereon, the following commissioners voted in favor thereof: _____. The following commissioners were absent and not voting: _____. The following commissioners voted nay: _____. The majority having voted aye, the motion was carried and the resolution was duly adopted.

Item Title: 2026 City Commission Meeting Calendar

Presented By: Rachel Richter Lordemann, Director of Communication

Requested Action/Staff Recommendation:

Approve 2026 West Fargo City Commission Meeting Schedule.

New Information:

The West Fargo City Commission will hold a regular meeting the first and third Monday of each month at 5:30 p.m. at the West Fargo City Commission Chambers, 2515 6th Street E, West Fargo, ND 58078. Meeting schedules in February and September will be adjusted to accommodate for holidays. A special meeting will be held at July 1, 2026 for the swearing in of the Mayor, Commissioners, and Municipal Judge following the June 2026 election.

Following approval, the meeting calendar will be published in the Newspaper of Record and on the City's website.

There are four months in 2026 that have five Mondays: March, June, August, and November. This may cause a delay in the approval of bills or other time sensitive items. If a special meeting must be called to address time sensitive items, a special meeting notice will be published per NDCC. This will be handled on a case-by-case basis.

Attached Supporting Documents:

- 2026 West Fargo City Commission Meeting Calendar

West Fargo City Commission

Bernie Dardis, Commission President
Brad Olson, Commission Vice President
Roben Anderson, Rory Jorgensen, Amy Zundel, Commissioners
Dustin Scott, City Administrator



2026 City of West Fargo Commission Meeting Calendar

January 5, 2026	January 19, 2026
February 2, 2026	February 17, 2026 <i>Moved from February 16 due to Presidents' Day Holiday</i>
March 2, 2026	March 16, 2026
April 6, 2026	April 20, 2026
May 4, 2026	May 18, 2026
June 1, 2026	June 15, 2026
July 1, 2026 – Special Meeting for New Commissioner Swearing In	
July 6, 2026	July 20, 2026
August 3, 2026	August 17, 2026
September 8, 2026 – <i>Moved from September 7 due to Labor Day Holiday</i>	September 21, 2026
October 5, 2026	October 19, 2026
November 2, 2026	November 16, 2026
December 7, 2026	December 21, 2026

*Months with five Mondays: March, June, August, November

*Special Meetings will be called on a case-by-case basis and noticed per NDCC

Approved Dec. 15, 2025



<input type="checkbox"/> Consent Agenda
<input checked="" type="checkbox"/> Regular Agenda

Item Title: Renew contract with Steven Mottinger for Indigent Defense Services

Presented By: Dustin Scott, City Administrator

Requested Action: Approve contract for Indigent Defense Services

Background:

For several years, the City has contracted with Steven Mottinger for Indigent Defense Services (a.k.a., court appointed attorney). The term of the current contract is set to expire in 2025 so we are requesting a renewal to extend his services through 2027. Mr. Mottinger has requested his monthly payment of \$5,250 to be increased to \$5,500. The 2026 budget for Court includes a line item amount of \$66,200 for this service.

2026-2027
CONTRACT FOR INDIGENT DEFENSE SERVICES
IN WEST FARGO, NORTH DAKOTA

This contract (the “Agreement”) is made between the undersigned attorney licensed to practice law in the State of North Dakota, hereinafter referred to as ATTORNEY, and the City of West Fargo, North Dakota, through its authorized representatives, hereinafter referred to as CITY.

- I. SERVICES COVERED. The ATTORNEY shall provide legal services for eligible indigent persons at all stages of the proceedings pursuant to Rule 1.1 of the North Dakota Rules of Professional Conduct.

- II. REPRESENTATION. The ATTORNEY shall represent indigent clients when, by Order of the Court, they are required to have representation and are eligible to be provided appointed counsel in the following categories of cases:
 1. Criminal cases prosecuted in West Fargo Municipal Court (“Court”), including Class B misdemeanors and infractions.
 2. Appeals to and/or cases removed to the District Court for Cass County.
 3. Retrial.
 4. Uniform post-conviction proceedings.
 5. Extraordinary proceedings such as habeas corpus or mandamus.
 6. Orders to Show Cause hearings.
 7. Restitution hearings.
 8. Contempt hearings.
 9. All other proceedings that may arise in Court, in which the Court deems that an indigent person requires the service of the public defender.

- III. INDIGENT PERSONS. An indigent person includes any person charged with the commission of a misdemeanor or any person required by law to be provided representation for the protection of his or her rights in any case listed in Section II above, and is a person found by the Court or any of its authorized officers to be eligible for court appointed counsel.

- IV. INITIAL APPOINTMENT. After receiving notice of appointment, the ATTORNEY shall interview the client within twenty-four (24) hours following the close of the next business day from the time of the appointment if the client is currently incarcerated; if the client is not currently incarcerated, then ATTORNEY shall interview the client within five (5) business days of the appointment. For appointments made during the weekend or on a holiday, the ATTORNEY shall interview the client the next business day.

- V. CONFLICT OF INTEREST. If at any time after an appointment has been made and the ATTORNEY discovers he or she must withdraw from the case pursuant to the North Dakota Rules of Professional Conduct, the ATTORNEY shall notify the judge of the court in which the matter is pending. The ATTORNEY shall follow the general provisions under Rule 11.2 of the North Dakota Rules of Court when withdrawing from a case.

- VI. AGREEMENT PERIOD. The duration of this Agreement shall be from January 1, 2026, through December 31, 2027. All necessary counsel services for cases or proceedings for which appointments are made to the ATTORNEY on or before December 31, 2027, shall be completed without further compensation as part of this Agreement. Additionally, the CITY shall have the right to annually renew this Agreement for the succeeding calendar year upon written notice to ATTORNEY at least thirty (30) days prior to its expiration.
- VII. PAYMENT FOR SERVICES. The ATTORNEY shall be paid the sum of Five Thousand Two Hundred Fifty Dollars (\$5,500) per calendar month for the period beginning on January 1, 2026, through December 31, 2027, payable in equal monthly installments at the end of the month in which the services are rendered. The City Auditor shall establish payment procedures. Similar payments will be made if this Agreement is renewed for additional annual terms as provided above.
- VIII. COSTS AND EXPENSES. The ATTORNEY shall pay for all costs, fees, and expenses incurred in providing Agreement services, except for the following expenses, which shall be paid by the CITY.
1. Witness fees.
 2. Sheriffs fees.
 3. Upon approval of the judge of the Court, extraordinary expenditures incurred by ATTORNEY may be reimbursed.

Prior approval of the judge is required for all expenses exceeding \$50.00 in total, in any one case.

The ATTORNEY will provide office space and supplies, clerical services, and support personnel. The ATTORNEY will provide all necessary books, equipment, furniture, malpractice insurance, photocopying expenses, and other necessities of the profession. In addition, absent extraordinary circumstances and pre-approval by the Court, the ATTORNEY, at his or her expense, will provide a backup/substitute attorney to appear in his or her stead at regularly scheduled hearings before the Court. Regularly scheduled hearings include, but are not limited to, the two (2) Wednesdays per month as set by the Court for trials and change of plea hearings.

- IX. RECORD KEEPING AND REPORTING. The ATTORNEY shall maintain individual case records showing services provided on each appointment for a period of three (3) years.
- X. INDEPENDENT CONTRACTOR. The ATTORNEY is an independent contractor and shall not for any reason whatever be considered the agent of or an employee of the CITY. ATTORNEY and CITY acknowledge that this Agreement does not create a partnership or joint venture between them and is exclusively a contract for service. The CITY is not required to pay, or make any contributions to, any social security, local, state, or federal tax, unemployment compensation, workers' compensation, insurance premium, profit-sharing, pension, or any other employee benefit for ATTORNEY during the term or any extensions hereto. ATTORNEY is responsible for paying, and complying with reporting requirements for, all local, state, and federal taxes related to payments made to ATTORNEY under this Agreement.

- XI. SUPERVISING AUTHORITY. The City Administrator shall be the supervising authority of this Agreement on behalf of the CITY.
- XII. INDEMNIFICATION. The ATTORNEY agrees to indemnify, defend, and hold harmless the CITY for malpractice claims made by persons represented by the ATTORNEY pursuant to this Agreement. This indemnification, defense, and hold harmless provision shall survive the termination of this Agreement and terminate six (6) years after the final date of any representation of a person represented by the ATTORNEY pursuant to this Agreement
- XIII. INSURANCE. The ATTORNEY shall carry professional liability insurance in the amount of at least \$100,000.00 for any liability arising out of services provided pursuant to this Agreement.
- XIV. TERMINATION. For good cause, the ATTORNEY or the CITY may terminate this Agreement upon sixty (60) days written notice to the other party. If so terminated, ATTORNEY shall continue work on cases assigned to ATTORNEY that are open as of the termination date until those cases are concluded and in accordance with Section VI.
- XV. NOTICE. All notices, requests, demands, or other communications required or permitted by the terms of this Agreement will be given in writing and delivered to the parties at the following addresses:

If to the CITY: City of West Fargo
 Attn: City Administrator
 2515 6th Street East
 West Fargo, ND 58078

If to ATTORNEY: Johnson, Mottinger, Greenwood Law Firm
 Attn: Steven D. Mottinger
 15 9th Street South
 Fargo, ND 58103.

A party may confirm in a prior written and signed writing to change or waive its notice address. Any notice given under this Agreement shall be deemed properly delivered (a) immediately upon being served personally, (b) five (5) calendar days after being deposited with the postal service if served by registered mail, or (c) the following day after being deposited with an overnight courier.

XVI. MISCELLANEOUS PROVISIONS.

1. Assignment. ATTORNEY will not voluntarily, or by operation of law, assign or otherwise transfer its obligations under this Agreement without the prior written consent of the CITY.
2. Merger. This Agreement constitutes the entire agreement between the parties. All negotiations and previous agreements or conditions concerning the subject matter of this Agreement are merged into this Agreement. This Agreement contains no representation, warranty, or collateral condition except as expressly provided for in this Agreement.

3. Severability. In the event that any of the provisions of this Agreement are held to be invalid or unenforceable in whole or in part, all other provisions will nevertheless continue to be valid and enforceable with the invalid or unenforceable parts severed from the remainder of this Agreement.
4. Remedies and Waiver. Except as expressly and specifically stated otherwise, nothing herein will limit the remedies and rights of the parties under and pursuant to this Agreement. The waiver by either party of a breach, default, delay, or omission of any of the provisions of this Agreement by the other party will not be construed as a waiver of any subsequent breach of the same or other provisions.
5. Governing Law. This Agreement shall be governed by and construed in accordance with the laws of the State of North Dakota.
6. Amendment. Any amendment or modification of this Agreement or additional obligation assumed by either party in connection with this Agreement will only be binding if evidenced in writing signed by each party or an authorized representative of each party.
7. Counterparts; Electronic Signatures. This Agreement may be executed in several counterparts, each of which shall be an original and all of which shall constitute but one and the same instrument. This Agreement shall not be effective until a counterpart has been signed by each party to be bound by it. The parties agree that an electronic signature to this Agreement shall be as valid as an original signature of the CITY and ATTORNEY and shall be effective to bind the signatories to this Agreement. For purposes hereof: (i) “electronic signature” means a manually signed original signature that is then transmitted by electronic means or an electronic acknowledgment which provides the signatory the ability to validate and affix a digital signature that is then transmitted by electronic means; and (ii) “transmitted by electronic means” means sent in the form of a facsimile or sent via the internet as a portable document format (“pdf”), via DocuSign, or other replicating image attached to an electronic mail or internet message.

[Remainder of page intentionally left blank.]

ATTORNEY:

Steven D. Mottinger, Attorney

Date

CITY:

Honorable Bernie L. Dardis, Mayor
City of West Fargo

Date

Dustin T. Scott, City Administrator
City of West Fargo

Date